

Evaluation and Comparative Analysis of Non-ionizing Electromagnetic Energy Emissions from New Leaf Energy Wind Turbines in The Town of Florida, Montgomery County, NY

Nov 21, 2023

Prepared for New Leaf Energy, Inc.

By

Smith and Fisher, LLC.



Kyle T. Fisher
Kevin T. Fisher

4791 Wintergreen Court
Woodbridge, VA 22192

EXECUTIVE SUMMARY	5
INTRODUCTION	7
BACKGROUND	8
RF Environment	8
Television Stations	9
FM Stations	10
AM Stations	12
Cellular Base Stations	13
Land Mobile	15
Airport Communications	17
Air Route Traffic Control Centers	17
Automated Weather Observing System	17
Common Traffic Advisory Frequency	18
Non-Directional Beacons	18
Universal Communications	19
VHF Omnidirectional Range	19
Nearby Airports	20
Amsterdam Airfield-NY87	20
FAA Data	20
Frequencies of Concern	20
Terrain Profile	21
Hogan Airport-NY05	22
FAA Data	22
Frequencies of Concern	22
Terrain Profile	22
Mariaville Aerodrome-8NY5	23
FAA Data	23
Frequencies of Concern	23
Terrain Profile	24
Ranch Airport-3NY0	24
FAA Data	24
Frequencies of Concern	25
Terrain Profile	25
Schenectady County Airport-SCH	26
FAA Data	26
Frequencies of Concern	27
Terrain Profile	27
Boston ARTCC	28
Frequencies of Concern	28

Albany International Airport-ALB	29
Frequencies of Concern	30
Radar Clutter Interference	30
“RF Sinking”	31
TEST DETAILS - PRE-CONSTRUCTION SURVEY	32
Test Equipment	32
Keysight FieldFox Spectrum Analyzer N9914A	32
Keysight N6850A Broadband Omnidirectional Antenna	32
Moonraker Ltd X1 HF Vertical Receive Antenna	33
Narda NBM-550 / EA5091	33
Narda SRM-3000	34
Onelinkmore RF Coaxial Adapter Connector Kit N Female to UHF PL-259 SO-239 Male Straight Adapter	35
WaveControl SMP2 / WP400	35
XRDS -RF KMR240 N Male Cable (10 feet)	37
Test Locations	37
Test Procedure	38
Broadband Low Frequency Measurements (1Hz-400kHz)	38
Broadband High Frequency Measurements (300 kHz-50GHz)	38
Narrowband Measurements	39
High Resolution Measurements	39
Weather Data	40
Monday June 12th, 2023	41
Tuesday June 13th, 2023	42
Wednesday June 14th, 2023	43
Wednesday November 15th, 2023	44
Thursday November 16th, 2023	45
TEST DATA - PRE-CONSTRUCTION SURVEY	46
Broadband Measurements (1Hz - 400kHz)	46
Broadband Measurements (300kHz-50GHz)	59
Narrowband Measurements	59
High Resolution Measurements	86
MITIGATION	132
REFERENCES	133
APPENDIX A - BACKGROUND	134
A.1 Map of Television Stations Within 50-Mile Radius of Proposed Site	135
A2.1 List of FM Stations Within 50-Mile Radius of Proposed Site	136
A2.2 Map of FM Stations Within 50-Mile Radius of Proposed Site	140
A3.1 Map of Known AT&T 4G Base Station Sites Near Proposed Site	141
A3.2 Map of Known Sprint 4G Base Station Sites Near Proposed Site	142
A3.3 Map of Known T-Mobile 4G Base Station Sites Near Proposed Site	143

A3.4 Map of Known T-Mobile 5G Base Station Sites Near Proposed Site	144
A3.5 Map of Known Verizon 4G Base Station Sites Near Proposed Site	145
APPENDIX B - TEST DETAILS	146
B1.1 Keysight FieldFox N9914A Datasheet	147
B1.2 Anritsu N6850A Broadband Omni-directional Antenna Datasheet	148
B1.3 Moonraker Ltd X1 HF Vertical Receive Antenna Datasheet	149
B1.4 Narda NBM-550 / EA5091 Datasheet	150
B1.5 Narda SRM-3000 Datasheet	151
B1.6 WaveControl SMP2 / WP400 Datasheet	152

EXECUTIVE SUMMARY

In a rural community, the sources of radio frequency (RF) signals are limited due to a number of factors such as the lack of commercial and industrial activity, fewer infrastructures supporting wireless technology, and less overall human activity. These factors contribute to a significantly different RF environment than one would find in urban or suburban areas.

Our measurement study involved a thorough analysis of the local RF environment using a spectrum analyzer, a device used for visualizing and measuring the amplitude of identified frequencies. The spectrum analyzer allowed us to see the frequency distribution of RF signals in the environment, providing insight into the RF landscape.

Our primary detections came from the AM (Amplitude Modulation) and FM (Frequency Modulation) bands.

Our measurements spanned across a wide range of frequencies, from 1 Hz to 50 GHz. This wide spectrum encompasses several types of RF signals, including television broadcasts, mobile phones, satellite communication, and Wi-Fi, among others. However, the overall energy measured across all these frequency bands was relatively low, indicating a lesser density of these signals in the area.

Of the frequencies of concern, noted in following sections, we measured the following total signal strength, using our Narda meters:

Measurement Paths/Locations	Signal Strength (V/m)
1 → 2	1.62
1 → 3	3.25
3 → 4	3.13
4 → 5	3.78
5 → 6	3.47
6 → 7	3.78
7 → 8	2.13
9	3.83
10	2.13
11	3.93
12	3.68
13	5.49
YMCA Road	2.75
Bean Hill Road	3.53

If the proposed turbine emits unwanted RF energy it will first be detected in the broadband measurements captured by this meter. We will then utilize the spectrum analyzer to determine the specific frequency and amplitude of the undesired signal in the post-construction measurement survey. These measurements will guide any mitigation measures should any interference be reported.

After the initial report was submitted to the board of the Town of Florida, it was requested that some high resolution measurements be taken at two of the previous locations. This was completed on November 15-16, 2023 with the same instrumentation used previously. There were 2 frequencies that were above the noise floor but were found to have very weak signals. These were found at 225 MHz with an amplitude of -118 dBm (in both AM and FM mode) at location 2 and -117 dBm (in both AM and FM mode) at location 13 and at 7.25 MHz with an amplitude of -107 dBm. The rest of the measurements were below the pre-amplified noise floor between -156 dBm and -136 dBm.

INTRODUCTION

This report is prepared in response to the request of a Town of Florida Board Member to evaluate the potential interference impact of a proposed wind turbine installation to be located at 153 YMCA Road, Amsterdam, New York, on the surrounding non-ionizing electromagnetic energy environment. The primary focus of this investigation is within a specific portion of the radio frequency (RF) spectrum ranging from 2 MHz to 200 MHz, given its relevance for potential interference concerns in the vicinity. However, due consideration and measurement will also be accorded to avionic frequencies employed by proximate airports and any nearby ground radar installations to ensure comprehensive coverage of potential sources of RF disruption.

As the proposed wind turbine has the potential to generate 60 Hz alternating current (AC) energy, with the produced voltage being fed into step-down transformers, there exists a possibility for the generation of RF noise from the turbine. Our past experiences with RF interference studies, predominantly conducted using a spectrum analyzer and an omni-directional antenna, form a reference point for this investigation. This study will involve taking signal strength measurements before and after construction of the wind turbine within the defined frequency range, beginning at the base of the proposed tower and including numerous other points around the site.

This report seeks to evaluate any potential adverse impacts on turbine-generated electromagnetic signals and consider confounding factors such as attenuation and multi-path distortion. The wind turbine's elevation above the surrounding terrain potentially compounds the concerns that its spurious emissions could elevate the detectable noise floor in the vicinity of the site..

Finally, the data gleaned from this RF analysis of the wind turbine installation will serve as a critical point of reference for addressing any future RF interference scenarios. Our objective is to ensure that the development of renewable energy resources such as wind turbines is conducted harmoniously with the existing radio frequency landscape.

Large wind turbines typically generate 60 Hz AC power with a 600V output. This is the U.S. power standard. For this reason, we will evaluate the RF energy at this frequency using out Low Frequency evaluation equipment as well.

BACKGROUND

RF Environment

There are many different technologies and methods of communication that contribute to the specific RF (radio frequency) environment in a given location, each operating within its own allocated frequency band:

- **Television (TV):** Terrestrial digital TV broadcasts operate in the very high frequency (VHF) and ultrahigh frequency (UHF) frequency bands (54-608 MHz). Satellite television operates in the super high frequency (SHF) band. These stations can occupy large bandwidths, sending out both video and audio signals to households. Their signals often require powerful transmitters and thus, if located close to a given area, can contribute substantially to the RF environment.
- **FM Radio:** Frequency Modulation (FM) radio operates within the VHF frequency band (between 88 and 108 MHz). These stations can propagate sound information (mostly music and talk) over a large area. Its signals can contribute to the RF environment in a large area but often have more limited range than AM signals.
- **AM Radio:** Amplitude Modulation (AM) radio operates in the MF band (around 535 to 1605 kHz). AM radio signals can travel far distances because their propagation occurs along the ground and is dependent on the conductivity of the earth along which the signal travels. In addition, AM signals can travel hundreds and thousands of miles due to it being reflected off a layer of the atmosphere called the ionosphere (which forms at sunset and dissipates at sunrise). Although the audio quality is lower than it is for FM stations (due to manmade electrical noise), these stations can be beneficial for voice-centric broadcasts such as talk shows and news.
- **Land Mobile Radio (LMR) Systems:** LMR systems are used by emergency services, businesses, and other organizations for short-range communications. These systems typically operate in VHF or UHF bands. They often use repeaters to increase their range and can significantly contribute to the RF environment, especially in urban areas.
- **Cellular Networks:** Cellular networks contribute significantly to the RF environment. They use multiple frequency bands ranging from UHF for second and third generation (2G/3G) services up to SHF for the newest fifth generation (5G) services. Cell base station antennas are scattered throughout populated areas, constantly transmitting signals to and from mobile devices.
- **Airport Communications:** Airport communications also play an important part in the RF environment. They use a variety of systems for different purposes, including navigation,

air traffic control, and airport operations, all using different portions of the RF spectrum. These systems include VHF for aircraft communications, SHF for radar systems, and even higher frequencies for satellite-based systems.

Each of these systems generates a significant amount of RF energy, which taken together forms the RF environment in a given location. The RF environment is continually monitored and regulated by the Federal Communications Commission to avoid interference between different systems that could lead to failures in the communication services.

Television Stations

Broadcast television signals, being a form of electromagnetic energy, can significantly contribute to the radio frequency (RF) environment within a 50-mile radius of their transmitter site. Here's a summary of the effects:

- **Occupies Spectrum:** Television stations occupy a specific 6 MHz channel within the VHF or UHF frequency spectrum, based on regulations defined by the Federal Communications Commission (FCC) in the United States. This spectrum is allocated to a specific broadcast station to avoid interference with other signals in the same or adjacent frequency bands in the same market or adjacent television market.
- **Interference:** If not properly regulated, the high-power signals can cause interference with other radio/television services operating within the vicinity of the transmitter. This interference can manifest as noise or distortion to other devices that operate in the same or nearby frequency bands.
- **Coverage and Signal Strength:** The intensity of the RF signal decreases with distance from the source due to the inverse square law. Therefore, within a 50-mile radius, there will be a gradual decline in signal strength. However, the actual coverage area can be influenced by factors like antenna height, terrain, and weather conditions. In ideal conditions, a high-powered TV station can provide a good signal within this range, but in practice, obstacles can create areas of weak reception.
- **Reflection, Refraction, and Diffraction:** TV signals can bounce off or be refracted by large buildings and other structures, and they can bend around obstacles, a phenomenon known as diffraction. These effects can cause both constructive and destructive interference, potentially causing signal 'ghosting' or multi-path interference in some areas.
- **Electromagnetic Compatibility:** Other electronic equipment, especially those that use RF signals, can experience operational issues due to the high-power signals of the TV broadcast station. These issues can be mitigated by using appropriate shielding and filtering techniques.

A broadcast TV signal has a significant contribution to the RF environment within its coverage range. Regulatory authorities often implement rules and guidelines to control this impact, ensuring that different technologies can co-exist within the same frequency spectrum without causing harmful interference to each other.

There are 20 stations authorized to operate by the Federal Communications Commission within 50 miles (80 km) of the proposed New Leaf Wind Turbine. They are listed below.

Call	Ch.	Frequency (MHz)	City	St	ERP (W)	Dist	Azi
WNYA	7	174-180	Pittsfield	MA	23	32.5	147.4
WXXA-TV	8	180-186	Albany	NY	22	32.5	147.4
WFNY-CD	16	482-488	Gloversville	NY	8.8	28.2	335.1
W18FE-D	18	494-500	Gloversville	NY	2.5	22.1	328.5
WYPX-TV	19	500-506	Amsterdam	NY	600	31.9	145
W21CP-D	21	512-518	Gloversville	NY	2.5	22.1	328.5
WNYT	21	512-518	Albany	NY	970	32.5	147.4
WCWN	22	518-524	Schenectady	NY	750	32.5	147.4
WTEN	24	530-536	Albany	NY	1000	32.5	147.4
WMHT	25	536-542	Schenectady	NY	445	32.5	147.4
WYBN-LD	26	542-548	Cobleskill	NY	15	32.3	147.2
WKTV	29	560-566	Utica	NY	708	63.6	294
WNCE-CD	31	572-578	Glens Fall	NY	15	60.6	39.9
WUCB-LD	32	578-584	Cobleskill	NY	9.4	34.6	224.8
WNGX-LD	33	584-590	Schenectady	NY	15	59.3	73.7
WRGB	35	596-602	Schenectady	NY	1000	32.5	147.4
WNGN-LD	36	602-608	Troy	NY	15	59.3	73.7
WVBG-LD	17+	488-594	Greenwich	NY	15	42.2	150.8
W21CQ	21+	512-518	Bennington	VT	50	59.3	73.6
WZPJ-LD	23+	524-536	Bennington	VT	15	31.9	145

In Appendix A.1 is a map of these stations with their FCC noise-limited service contours plotted in relation to the proposed New Leaf wind turbine and airfields in the area.

FM Stations

A Broadcast FM signal also tends to influence the Radio Frequency (RF) environment within a 50-mile radius of its transmitter site in several ways:

- Occupies Spectrum: One of the most immediate impacts is that a given station occupies a specific frequency in the RF spectrum, between 88.1 MHz to 107.9 MHz in most parts of the world. Each FM station requires a specific frequency slot to broadcast its signal.

- **Interference:** High-power FM broadcast signals can potentially interfere with other users of the RF spectrum. This is most likely to occur with adjacent frequencies (e.g., other FM radio stations broadcasting close to the same frequency). To avoid this, the FCC allocates frequencies and power levels and ensures sufficient physical separation between FM stations on the same and adjacent frequencies.
- **Coverage Area:** An FM signal radiates out from the transmitter site and attenuates, or diminishes, with distance. Within a 50-mile radius, a high-powered transmitter should be strong enough to provide a reasonably clear signal. However, factors such as the antenna's height above the surrounding terrain, transmitter power, frequency, and local terrain can all affect the actual coverage area of a given station.
- **Multipath Propagation:** In urban environments, the RF signal can reflect off buildings, leading to multipath propagation where several copies of the signal arrive at a given receiver at slightly different times. This can cause distortion or "fading" of the FM signal.
- **Impacts on Other Devices:** FM transmitters, especially high-power ones, may cause interference with electronic devices within close proximity. This is most likely with poorly shielded devices or devices that operate at frequencies harmonically related to the FM signal.
- **Potential Intermodulation:** When multiple RF signals are present (as in a broadcast environment with multiple stations), signals can mix and produce emissions on new frequencies called intermodulation products. If these new frequencies align with other operational frequencies in the area, they can cause interference to a device..
- **Terrain Effect:** Terrain plays a significant role in how the FM signal affects the RF environment. Mountainous or hilly terrain can obstruct the signal, while flat terrain or water can enhance the signal's reach.

A well-managed FM transmission station will try to minimize its negative impact on the surrounding RF environment by adhering to proper standards and regulations set by regulatory bodies like the FCC.

There are 113 FM stations with a 50-mile radius arc around the New Leaf Wind Turbine site in Amsterdam, NY.

Due to the size of the table it has been added in Appendix A2.1 of this report.

Additionally, in the Appendix is a map of these stations and their FCC contours plotted in relation to the New Leaf wind turbine as well as airfields located in the area.

AM Stations

Broadcasting an AM (Amplitude Modulation) signal from a transmitter site has several effects on the RF (Radio Frequency) environment within a 50-mile radius. The influence of the signal largely depends on the power of the transmitter, the height and type of the antenna (which is the AM tower itself), and the soil conductivity and atmospheric conditions.

- **Signal Propagation:** The most immediate effect of broadcasting an AM signal is an increase in the overall RF environment within a 50-mile radius of the transmitter site. The broadcast signal will travel through the environment and will be detectable by any capable receiver within the range.
- **Interference:** One of the main ways an AM signal can adversely affect the RF environment is a result of interference to other AM stations. If there are other nearby AM signals within the same or adjacent operating frequency, a receiver may experience interference. The same holds true if there are devices within the operating radius of the AM station that are sensitive to the broadcast frequency. This interference can cause issues with the quality of the received signals.
- **Skywave Propagation:** Unlike FM signals, AM signals can bounce off the Earth's ionosphere, a phenomenon known as skywave propagation. This can extend their reach beyond the immediate 50-mile radius when the ionosphere forms at sunset. Conversely, skywave propagation can also create interference with other distant AM stations broadcasting on the same or adjacent frequency.
- **Ground Wave Propagation:** During daylight hours, AM signals propagate via the ground wave, hugging the surface of the earth. This allows the signal to bend around the Earth's surface and reach beyond the horizon. Ground wave propagation is responsible for the signal coverage within the 50-mile radius and is heavily dependent on the conductivity of the soil over which it travels.
- **Effects on Electrical Equipment:** A strong AM signal can induce voltages in electrical circuits, especially if those circuits are resonant at or near the broadcast frequency. This can lead to humming or buzzing noises in audio equipment or cause malfunctions in sensitive devices.
- **Noise Generation:** The broadcasting of AM signals may also introduce noise into the RF environment. This noise could come from the signal's modulation process, the transmitter hardware, or even environmental factors. This noise can impact other signals and receivers in the environment, especially around the AM station's transmitter site.

It's also important to note that the Federal Communications Commission (FCC) has regulations in place to manage these effects. They allocate specific frequency bands for different uses and

set maximum power levels for transmitters to minimize interference and manage the overall RF environment.

There are 22 AM stations licensed within a 50 mile radius of the proposed New Leaf wind turbine. Below is a screenshot of the licensed stations from the FCC's database.

WDOF	AM 730	kHz ND2	Daytime	D B LIC	ONEONTA	NY US BL-20051103AEG	1.0	kw	68738	49.72	km	30.90	mi	202.28'	TOWNSQUARE LICENSE, LLC
WDOF	AM 730	kHz ND2	Nighttime	D B LIC	ONEONTA	NY US BL-20051103AEG	0.008	kw	68738	49.72	km	30.90	mi	202.28'	TOWNSQUARE LICENSE, LLC
WGV	AM 810	kHz ND2	Daytime	A A LIC	SCHENECTADY	NY US BL-20161118ACO	50.0	kw	15329	62.86	km	39.06	mi	97.84'	IHM LICENSES, LLC
WGV	AM 810	kHz ND2	Nighttime	A A LIC	SCHENECTADY	NY US BL-20161118ACO	50.0	kw	15329	62.86	km	39.06	mi	97.84'	IHM LICENSES, LLC
WZR	AM 930	kHz ND1	Daytime	D B LIC	JOHNSTOWN	NY US BL-12288	1.0	kw	27553	36.73	km	22.82	mi	67.35'	CRANESVILLE BLOCK COMPANY, INC.
WZR	AM 930	kHz ND1	Nighttime	D B LIC	JOHNSTOWN	NY US BL-12288	0.028	kw	27553	36.73	km	22.82	mi	67.35'	CRANESVILLE BLOCK COMPANY, INC.
WIBX	AM 950	kHz DA2	Daytime	B B LIC	UTICA	NY US BWML-20161115ACX	5.0	kw	168	52.77	km	32.79	mi	299.38'	TOWNSQUARE MEDIA LICENSEE OF UTICA/ROME, INC.
WIBX	AM 950	kHz DA2	Nighttime	B B LIC	UTICA	NY US BWML-20161115ACX	5.0	kw	168	52.77	km	32.79	mi	299.38'	TOWNSQUARE MEDIA LICENSEE OF UTICA/ROME, INC.
WCHN	AM 970	kHz ND1	Daytime	D B LIC	NORWICH	NY US BL-20050525ASB	1.0	kw	13826	71.32	km	44.32	mi	235.52'	TOWNSQUARE LICENSE, LLC
WCHN	AM 970	kHz ND1	Nighttime	D B LIC	NORWICH	NY US BL-20050525ASB	0.034	kw	13826	71.32	km	44.32	mi	235.52'	TOWNSQUARE LICENSE, LLC
WOPX	AM 980	kHz DAN	Daytime	B B LIC	TROY	NY US BWML-20200403ABA	5.0	kw	37233	77.31	km	48.04	mi	97.08'	IHM LICENSES, LLC
WOPX	AM 980	kHz DAN	Nighttime	B B LIC	TROY	NY US BWML-20200403ABA	5.0	kw	37233	77.31	km	48.04	mi	97.08'	IHM LICENSES, LLC
WKAJ	AM 1120	kHz DA2	Daytime	B B LIC	SAINT JOHNSVILLE	NY US BWML-20121015ADC	10.0	kw	160470	15.77	km	9.80	mi	25.61'	CRANESVILLE BLOCK COMPANY, INC.
WKAJ	AM 1120	kHz DA2	Nighttime	B B LIC	SAINT JOHNSVILLE	NY US BWML-20121015ADC	0.4	kw	160470	15.77	km	9.80	mi	25.61'	CRANESVILLE BLOCK COMPANY, INC.
WDE	AM 1190	kHz ND2	Daytime	D B LIC	COBLESKILL	NY US BL-20081023ACA	1.0	kw	4002	33.70	km	20.94	mi	126.61'	SCHOHARIE BROADCASTING, LLC
WDE	AM 1190	kHz ND2	Nighttime	D B LIC	COBLESKILL	NY US BL-20081023ACA	0.02	kw	4002	33.70	km	20.94	mi	126.61'	SCHOHARIE BROADCASTING, LLC
WXTV	AM 1230	kHz ND1	Unlimited	C C LIC	LITTLE FALLS	NY US BL-9950	1.0	kw	57701	20.14	km	12.52	mi	340.41'	GALAXY UTICA LICENSE LLC (NEW)
WPTX	AM 1240	kHz ND1	Unlimited	C C LIC	SCHENECTADY	NY US BL-8381	1.0	kw	8726	64.85	km	40.30	mi	95.79'	AREA INDEPENDENT RADIO, INC.
WTLB	AM 1310	kHz DA2	Daytime	B B LIC	UTICA	NY US BL-19830817A7	5.0	kw	54548	45.78	km	28.45	mi	296.84'	GALAXY UTICA LICENSE LLC (NEW)
WTLB	AM 1310	kHz DA2	Nighttime	B B LIC	UTICA	NY US BL-19830817A7	0.5	kw	54548	45.78	km	28.45	mi	296.84'	GALAXY UTICA LICENSE LLC (NEW)
WENT	AM 1340	kHz ND1	Unlimited	C C LIC	GLOVERSVILLE	NY US BL-9234	1.0	kw	72291	38.38	km	23.85	mi	63.52'	THK TANK MEDIA, INC.
WNNY	AM 1350	kHz ND1	Daytime	D B LIC	ROME	NY US BL-7661	0.5	kw	53657	66.57	km	42.61	mi	302.94'	GALAXY UTICA LICENSE LLC (NEW)
WNNY	AM 1350	kHz ND1	Nighttime	D B LIC	ROME	NY US BL-7661	0.057	kw	53657	66.57	km	42.61	mi	302.94'	GALAXY UTICA LICENSE LLC (NEW)
WNR5	AM 1420	kHz ND2	Daytime	D B LIC	HERKIMER	NY US BL-19870619AD	1.0	kw	2760	29.46	km	18.30	mi	315.67'	ARJUNA BROADCASTING CORP.
WNR5	AM 1420	kHz ND2	Nighttime	D B LIC	HERKIMER	NY US BL-19870619AD	0.064	kw	2760	29.46	km	18.30	mi	315.67'	ARJUNA BROADCASTING CORP.
WENY	AM 1440	kHz DAN	Daytime	B B LIC	GLOVERSVILLE	NY US BL-20100324ADX	5.0	kw	129191	38.92	km	24.18	mi	62.54'	MICHAEL A. SLEEZER
WENY	AM 1440	kHz DAN	Nighttime	B B LIC	GLOVERSVILLE	NY US BL-20100324ADX	0.5	kw	129191	38.92	km	24.18	mi	62.54'	MICHAEL A. SLEEZER
WKAL	AM 1450	kHz ND2	Daytime	C C LIC	ROME	NY US BWL-20110405ABW	1.0	kw	72067	66.13	km	42.33	mi	303.17'	TUNE IN BROADCASTING, LLC
WKAL	AM 1450	kHz ND2	Nighttime	C C LIC	ROME	NY US BWL-20110405ABW	1.0	kw	72067	66.13	km	42.33	mi	303.17'	TUNE IN BROADCASTING, LLC
WRCR	AM 1480	kHz ND1	Daytime	D B LIC	RENSEN	NY US BWL-20160201AOK	5.0	kw	466	59.90	km	37.22	mi	327.33'	PHOENIX RADIO, INC.
WRCR	AM 1480	kHz ND1	Nighttime	C C LIC	AMSTERDAM	NY US BL-9329	1.0	kw	49329	30.93	mi	78.30	mi	78.30'	CRANESVILLE BLOCK COMPANY
WDDO	AM 1490	kHz ND1	Unlimited	C C LIC	SIDNEY	NY US BL-19820520AB	1.0	kw	9685	78.66	km	48.88	mi	215.37'	LDO BROADCASTING, INC.
WUSP	AM 1530	kHz ND2	Daytime	D B LIC	UTICA	NY US BL-11607	1.0	kw	4680	47.47	km	29.50	mi	304.60'	PHOENIX RADIO, INC.
WUSP	AM 1530	kHz ND2	Nighttime	D B LIC	UTICA	NY US BL-11607	0.003	kw	4680	47.47	km	29.50	mi	304.60'	PHOENIX RADIO, INC.
WVTL	AM 1570	kHz ND1	Daytime	B B LIC	AMSTERDAM	NY US BL-11127	1.0	kw	72624	45.63	km	28.36	mi	38.40'	ROSER COMMUNICATIONS NETWORK, INC.
WVTL	AM 1570	kHz ND1	Nighttime	B B LIC	AMSTERDAM	NY US BL-11127	0.204	kw	72624	45.63	km	28.36	mi	38.40'	ROSER COMMUNICATIONS NETWORK, INC.
WRCR	AM 1600	kHz ND1	Daytime	D B LIC	ONEIDA	NY US BL-6347	1.0	kw	70890	78.29	km	48.65	mi	287.88'	TOWERCAST MEDIA, LLC
WRCR	AM 1600	kHz ND1	Nighttime	D B LIC	ONEIDA	NY US BL-6347	0.02	kw	70890	78.29	km	48.65	mi	287.88'	TOWERCAST MEDIA, LLC

*** 38 AM Records within 80.00 km distance of 42° 52' 18.90" N, 74° 46' 30.30" W ***

Cellular Base Stations

Cellular radio signals have a significant impact on the RF (Radio Frequency) environment within a 10-mile radius of its transmitter (base station) site. Base station antennas can be mounted on towers, attached to rooftops, as well as mounted atop power line stanchions and water towers. Here are some of the main ways that these signals can affect the RF environment:

- **Signal Propagation:** When a cellular base station transmits a signal, it propagates until obstacles such as buildings or terrain disrupt it. These signals can travel up to 10 miles, although their signal strength decreases significantly with distance. The resulting signal distribution forms a "cell," which gives cellular networks their name.
- **Interference:** In a dense area with several different transmitter sites within a 10-mile radius, there may be interference between the different signals. This interference can degrade signal quality and lead to dropped calls or slow data speeds. In modern cellular networks, different techniques like frequency reuse, spatial diversity, and beamforming are used to minimize this interference.
- **Frequency Spectrum Utilization:** Each cellular signal uses a specific portion of the RF spectrum. In a 10-mile radius, if multiple transmitters are using the same frequencies, they could interfere with each other. Therefore, proper frequency management and coordination between different networks is essential.
- **Coverage Holes:** Due to physical barriers and the nature of RF propagation, there can be coverage holes or areas where adequate signal does not reach consumers' devices or is significantly attenuated. These areas may experience poor cellular reception.

- **Noise Floor:** The collective RF signals from multiple sources, including cell base stations, create a "noise floor" – the baseline level of RF energy in the environment. A higher noise floor can make it harder for receivers to pick out the signal they're looking for, particularly if it's a weak signal.
- **Multipath Propagation:** This phenomenon occurs when signals bounce off buildings, mountains, or other obstacles, arriving at the receiving antenna from different paths and therefore at slightly different times. This can cause constructive and destructive interference, affecting the quality of signal received.

Cellular radio signals can affect the RF environment in a variety of ways. It's the role of RF engineers to design and manage cellular networks in a way that maximizes coverage and quality while minimizing negative impacts like interference.

Below is a list of the bands in use by the four major carriers operating in and around the proposed wind turbine site.

Bands	Lower Frequency (MHz)	Upper Frequency (MHz)	Service	Duplexing
2	1930	1989.9	PCS Blocks A-F	FDD
4	2110	2154.9	AWS-1	FDD
5	869	893.9	CLR	FDD
12	729	745.9	Lower SMH Block A/B/C	FDD
13	746	755.9	Upper SMH Block C	FDD
14	758	767.9	Upper SMH Block D	FDD
17	734	745.9	Lower SMH Block B/C	FDD
18	860	874.9	Lower 800	FDD
25	1930	1994.9	E-PCS Blocks A-G	FDD
26	859	893.9	E-CLR	FDD
29	717	727.9	Lower SMH Block D/E	FDD
30	2350	2359.9	WCS Block A/B	FDD
41	2496	2689.9	BRS/EBS	TDD
46	5150	5904.9	U-NII	TDD
48	3550	3699.9	CBRS	TDD
66	2110	2199.9	AWS 1-3	FDD
71	617	651.9	600MHz US	FDD
n25	1930	1995	E-PCS	FDD
n41	2496	2689.99	BRS/EBS	TDD
n66	2110	2200	AWS-3	FDD
n71	617	652	600 MHz	FDD
n261	27499.96	28349.92	28 GHz	TDD
1900	1850	1990	GSM	FDD

Below is a map with known base stations from T-Mobile's 5G Bands plotted on a map near the proposed New Leaf wind turbine site.

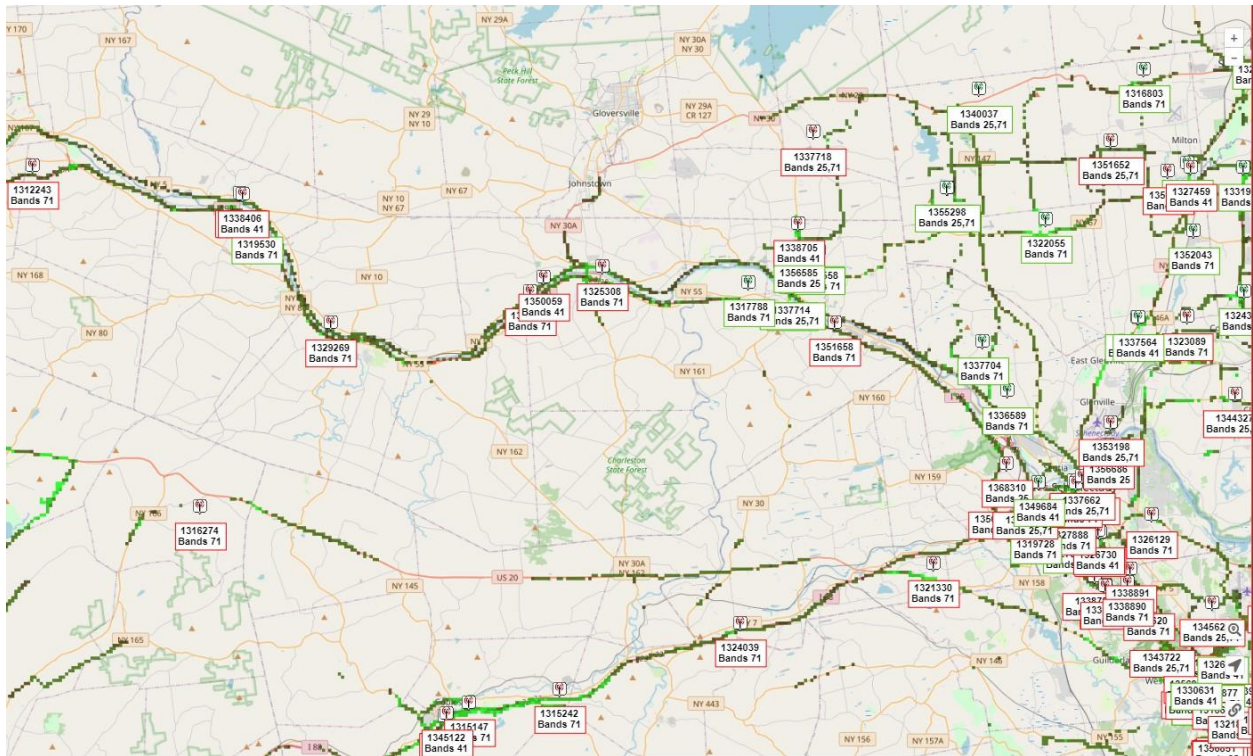

The Appendix has maps with locations of the base stations of all 4 major carriers in relation to the Wind Turbine and nearby airports.

Land Mobile

Land Mobile Radio (LMR) systems play a crucial role in communications, particularly for public safety, emergency services, military, and commercial applications. LMR systems are designed to provide communication over relatively short distances (typically within a 10 mile radius) and are often used where mobile communication is essential, such as in emergency response and field service operations.

Here's a general idea of how a LMR signal affects the RF (radio frequency) environment within a 10-mile radius of its transmitter site:

- Occupation of RF Spectrum: LMR operates within specific frequency bands. In the United States, for example, commercial radios are typically available in the VHF and UHF frequency bands. 30–50 MHz (sometimes called "Low VHF Band" or "Low Band"), 150–172 MHz (sometimes called "High VHF Band" or "High Band"), 450–470 MHz "UHF". Many larger populated areas have additional UHF frequencies from 470 to 490 MHz, and 490–512 MHz. There are also frequencies in the 800 and 900 MHz range

available. Commercial, public safety and government users are required to obtain U.S. Federal Communications Commission licensing in the United States. Any active transmission within these bands would occupy a chunk of the RF spectrum, thus making it unavailable for other users or services operating on the same frequencies.

- **Interference:** The strength and quality of the LMR signal decrease as the distance from the transmitter increases. Near the transmitter, the signal will be strong, but it may interfere with other communication systems operating on the same or nearby frequencies. This interference can manifest as noise, distortion, or even complete disruption of the affected signal. This is one of the reasons why careful frequency coordination and assignment is essential.
- **Coverage Area:** The effective communication radius for LMR systems is influenced by the transmitter power, antenna height, terrain, and the type and quality of the receiving equipment. Typically, a single LMR base station can cover an area within a 10-mile radius fairly effectively, but obstructions such as buildings, hills, or trees can reduce the effective range and create "dead zones" where the signal is weak or nonexistent.
- **Reflection, Refraction, and Diffraction:** Like any radio signal, LMR signals can be reflected, refracted, and diffracted by various objects and terrain features. This can create areas where the signal is unexpectedly strong or weak, even within the intended coverage area.
- **Multipath Propagation:** This is a phenomenon where the transmitted signals reach the receiving antenna by two or more paths due to reflection, refraction, or diffraction. This can cause signal fading or interference at the receiver, reducing the quality of communication.
- **Saturation:** In heavily populated areas or places with many active LMR systems, the RF environment can become "saturated," with more signals than the available spectrum can comfortably accommodate. This can lead to increased interference and reduced communication quality.

A LMR transmitter can have a significant impact on the RF environment within its coverage area. However, with careful frequency management and system design, these impacts can be minimized, allowing the LMR system to coexist with other RF services.

Within a 10-mile radius of the proposed New Leaf wind turbine there are thousands of licensed LMR services. This link contains a file with all the LMR services within a 10-mile radius of the Amsterdam wind turbine:

https://drive.google.com/file/d/1KJvW7CDMSe0fc9tWAdYuNy0159397_9W/view?usp=sharing

Airport Communications

Air Route Traffic Control Centers

Air Route Traffic Control Centers (ARTCC) are facilities in the United States that manage the flow of air traffic between airports. They are responsible for controlling aircraft en route in a specific region of airspace, usually in the cruising phase of the flight. The U.S. has 21 ARTCCs, each controlling a different region of airspace.

As for radio communication, ARTCCs typically operate within the aviation or aeronautical band, which falls within the VHF radio band, between 118 and 137 MHz (megahertz). Most of these VHF radio assignments also have a UHF (225 to 380 MHz) paired frequency used for military flights.

The specific frequencies a given ARTCC uses can vary significantly and are determined by factors like the volume of air traffic, geographic area, and type of operations (for example, high altitude vs. low altitude). Therefore, each ARTCC has a set of frequencies assigned to them for their operation.

However, it's essential to note that the exact frequency an aircraft would use to communicate with an ARTCC depends on the specific sector of airspace it is flying in at the time. Airspace is divided into sectors, each with its own frequency, to manage the volume of air traffic efficiently. Therefore, the frequency an aircraft uses could change several times during a single flight.

The Federal Aviation Administration (FAA) maintains a comprehensive list of frequencies for each ARTCC and their sectors, which can typically be found in resources such as the Chart Supplement (formerly the Airport/Facility Directory or A/FD) or on sectional aeronautical charts.

Automated Weather Observing System

AWOS stands for "Automated Weather Observing System". It's a suite of sensors which automatically generate a series of weather data for pilots, meteorologists, and other users.

The numbers following AWOS, such as AWOS-3, denote different versions or levels of the system, with each providing a different set of data.

Specifically, AWOS-3 provides the following weather information:

- Altimeter setting: This indicates the atmospheric pressure at sea level, which pilots use to calibrate their aircraft's altimeter.
- Wind data: Speed and direction.
- Temperature and dew point: These can be used to calculate relative humidity and potential for icing conditions.

- **Visibility:** Measured in statute miles, this indicates the maximum distance at which large objects can be clearly seen.
- **Sky condition:** This refers to the amount and type of cloud cover, up to 12,000 feet.

This system operates continuously (24/7) and can be accessed by pilots both in-flight and on the ground. It's particularly useful for those flying under visual flight rules (VFR), as it can provide timely and accurate updates on current weather conditions in a given area.

Common Traffic Advisory Frequency

Common Traffic Advisory Frequency (CTAF) is a communication frequency used by pilots in general aviation to transmit their intentions to other aircraft in the vicinity, typically when they're within 10 miles of an airport and below 10,000 feet altitude. The CTAF is primarily used at non-towered airports or during the hours when a towered airport is not in operation.

In the United States, CTAF frequencies are typically found in the VHF band, and ranges from 118.0 to 136.975 MHz, with a majority of them within the aircraft band of 122.700 to 123.575 MHz.

The specific frequency used as the CTAF can vary from one airport to another, and pilots consult the appropriate aeronautical charts or publications for the correct frequencies. When a UNICOM frequency is available and no other frequency is listed as the CTAF, pilots may use the UNICOM frequency to announce their intentions. It is also important for pilots to continually monitor and communicate on the appropriate frequency for the area in which they are flying.

Non-Directional Beacons

A Non-Directional Beacon (NDB) is a radio transmitter that is used as a navigational aid in aviation. It emits an omnidirectional signal that is received by an aircraft's Automatic Direction Finder (ADF), which allows pilots to determine their bearing to or from the beacon.

NDBs are characterized by the following:

- **Omnidirectional Signal:** Unlike some other navigational aids, an NDB does not provide any indication of the direction to the beacon from the aircraft. Instead, it simply transmits a signal in all directions, and the aircraft's ADF calculates the direction based on the received signal.
- **Low Frequency:** NDBs typically operate in the frequency range of 190 kHz to 535 kHz, which is classified as the low-frequency band in radio communication. This allows their signals to follow the Earth's curvature, providing good range even at relatively low altitudes.

- ADF Required: To use an NDB, an aircraft must be equipped with an Automatic Direction Finder. This instrument points towards the beacon, enabling the pilot to navigate towards or away from it.
- Morse Code: NDBs typically identify themselves by transmitting their identifier in Morse Code. This allows pilots to verify that they are receiving the correct beacon.
- Limitations: NDB signals can be affected by several factors such as thunderstorms, terrain, and even the aircraft's own structure. This can sometimes lead to inaccuracies in the indicated direction. They are also less precise than some other forms of radio navigation, which has led to a decrease in their use in many parts of the world.

Despite these limitations, NDBs and ADFs continue to be used, particularly in areas with less advanced aviation infrastructure or in smaller aircraft that may not be equipped with more advanced systems.

Universal Communications

UNICOM in aviation refers to a non-controlled communication system utilized in airports for the exchange of information between pilots and ground service providers. Its purpose is to aid in the coordination of ground operations such as fueling, hangering, parking, and other related services.

UNICOM is generally used in smaller airports where there isn't a control tower or the control tower is not operational 24/7. At larger airports, UNICOM may be used for non-critical communications such as those with Fixed Base Operators (FBOs) for services like fueling and towing.

UNICOM traditionally operates on the VHF band, with two primary frequencies being 122.950 MHz and 122.700 MHz. Some airports use other frequencies as well, typically in the 122 - 123 MHz range. Specific frequencies are assigned to different airports to prevent interference, and the assigned frequency will usually be listed in the airport's information in navigational charts or directories.

VHF Omnidirectional Range

VHF Omnidirectional Range (VOR) is a type of short-range radio navigation system for aircraft, enabling aircraft with a receiving unit to determine their position and stay on course by receiving radio signals transmitted by a network of fixed ground radio beacons. It uses frequencies in the very high frequency (VHF) band from 108.00 to 117.95 MHz.

The "omnidirectional" part of VOR refers to the fact that the signals are broadcast in all directions from the beacon. An aircraft can receive these signals and use them to determine its bearing or direction from the station, thus providing a navigational fix. The VOR network can be

used to create "airways" in the sky which aircraft can follow, providing a direct path between different beacons.

VOR is typically combined with other navigational systems, such as the Distance Measuring Equipment (DME), to provide more complete navigational information. For example, while VOR tells the aircraft its direction from the beacon, DME can tell it how far away it is. This way, the aircraft can know both its direction and distance from a fixed point, allowing it to accurately determine its current position.

VOR remains a common form of aviation navigation, though it is being gradually phased out and replaced with satellite-based navigation systems like the Global Positioning System (GPS) in many parts of the world. It is however still crucial in areas with poor GPS coverage or during GPS outages.

Nearby Airports

Amsterdam Airfield-NY87

FAA Data

Amsterdam Airfield is a private airfield with the FAA Identifier NY87. The airport is located at a latitude and longitude of 42-57.754433N 074-15.224583W, approximately 1 mile west of Fort Johnson, NY, with an estimated elevation of 340 ft. The airport's zip code is 12070.

The airport is for private use only and requires permission before any aircraft can land. It was activated in October 1947. There is no control tower, and the airport is unattended. However, there is a wind indicator, and a landing fee is applied, particularly on unauthorized landings.

The airport doesn't offer any airframe or powerplant services. Its runway, designated E/W, has dimensions of 1450 x 160 ft. and is surfaced with turf. Both east and west traffic patterns are to the left.

The airport is privately owned by Charles J. Skee, located at 318 Guy Park Ave, Amsterdam, NY 12010. There are five single-engine airplanes based on the field.

Remarks note a radio tower 80' north of the hangars and hefty fees for unauthorized landing or use. For clearance delivery an aviator would contact Albany Approach.

Frequencies of Concern

Below are the frequencies that would be used by an aviator utilizing this airfield.

Service	Use	Frequency (MHz)	Location	Distance from NY87 (nm)	Hdg/Rad from NY87
AWOS-3	Weather	119.225	NY0	4	NW
AWOS-3	Weather	119.275	SCH	16	SE
AWOS-3	Weather	132.025	5B2	18	E
VOR	Navigation	115.3	ALB	23.7	316
VOR	Navigation	115.0	CAM	40.0	281
NDB	Approach	0.523	Johnstown	4.1	137
NDB	Approach	0.356	Hunter	15.5	309

Terrain Profile

Below is the terrain profile utilizing the proposed wind turbine site as the starting point and the airfield as the end point. The red line indicates the terrain profile. The green line represents Line of Sight. The orange line indicates the Fresnel Zone clearance. If any terrain falls within this zone there is a chance for degradation of a hypothetical source signal (which would be a positive in this case since it would be an unwanted signal potentially being generated by the wind turbine). The terrain profile below does not take into account the height of the wind turbine nor the equipment height at the airport.

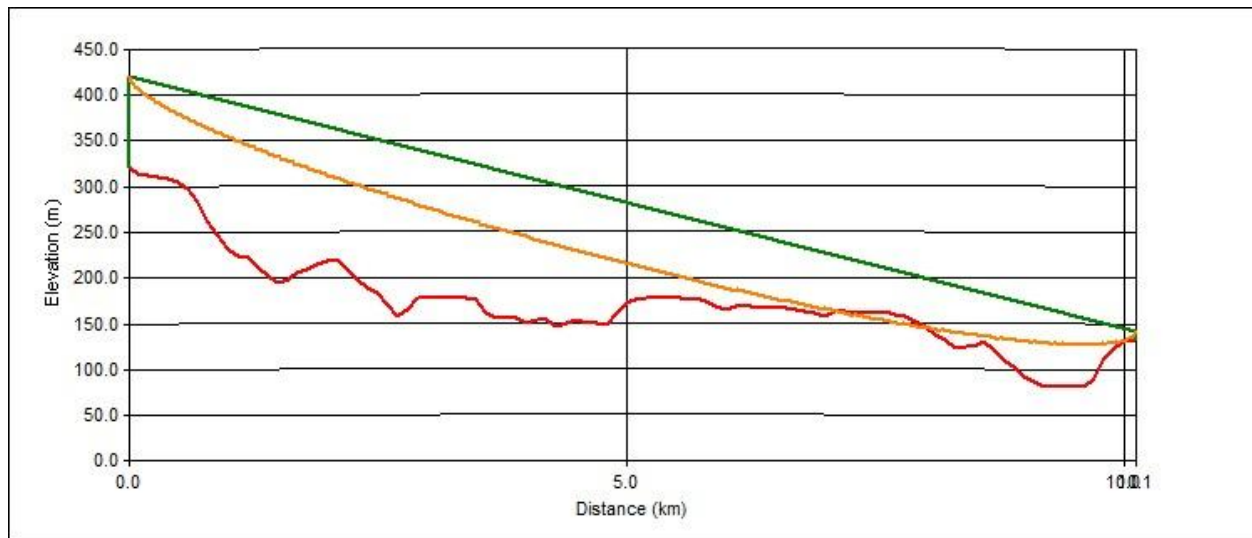

Hogan Airport-NY05

FAA Data

Hogan Airport is a private-use airport identified by the FAA Identifier NY05, effective from 18 May 2023. The airport is located at latitude 42.7814633N and longitude -74.3256869W, with an estimated elevation of 1260 feet (384 meters). The location is approximately 4 miles west of Esperance, NY, in the zip code 12160.

The airport requires permission for landing. It was activated in October 1981 and doesn't have a control tower. The airport's ARTCC is Boston Center, and it is served by the Burlington Flight Service Station. There is a wind indicator, but no segmented circle.

The airport includes two runways. Runway 12L/30R is 3000 by 27 feet (914 by 8 meters), has a surface of asphalt/turf in good condition, and features low-intensity edge lights. Runway 12R/30L is also 3000 feet long but is 130 feet wide (914 by 40 meters) with a turf surface. Both runways have a left traffic pattern.

The airport is privately owned by Tim Hogan, who is also the manager. He can be contacted at two provided phone numbers for different addresses. There are four single-engine airplanes based at this airfield. For clearance delivery an aviator would contact Albany APCH.

Frequencies of Concern

Below are the frequencies that would be used by an aviator utilizing this airfield.

Service	Use	Frequency (MHz)	Location	Distance from NY05 (nm)	Hdg/Rad from NY05
AWOS-3	Weather	119.225	NY0	13	N
AWOS-3	Weather	119.275	SCH	18	E
VOR	Navigation	115.3	ALB	23.1	288
NDB	Approach	0.523	Johnstown	13.1	193
NDB	Approach	0.356	Hunter	17.8	270

Terrain Profile

Below the terrain profile utilizing the proposed wind turbine site as the starting point and the airfield as the end point. The red line indicates the terrain profile. The green line represents Line of Sight. The orange line indicates the Fresnel Zone. If any terrain falls within this zone there is a chance for degradation of a hypothetical source signal (which would be a positive in this case since it would be an unwanted signal potentially being generated by the wind turbine). The terrain profile below does not take into account the height of the wind turbine nor the equipment height at the airport.

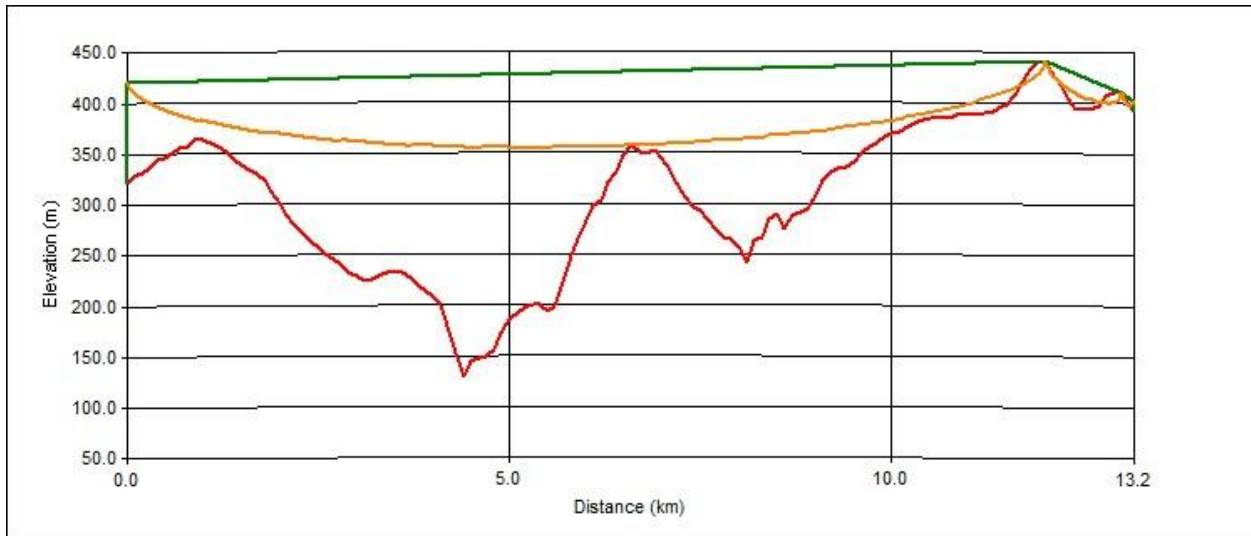

Mariaville Aerodrome-8NY5

FAA Data

Mariaville Aerodrome is a privately-owned airport with FAA Identifier 8NY5. Located 4 miles north of Duanesburg, NY, it has a latitude/longitude of 42-49.221167N 074-08.891000W and an estimated elevation of 1260 ft.

The airport doesn't have a control tower, but operations are managed by the Boston ARTCC and the Burlington Flight Service Station. The airport's use requires permission prior to landing. It has been activated since August 1994.

The airport features one runway, Runway 10/28, which has dimensions of 1820 x 100 ft and is surfaced with turf. Traffic patterns for both directions are left-handed.

Ownership and management are both handled by Clifford A. Souza, who can be contacted at 518-879-1065. There is one single-engine airplane based at this field. The additional remarks indicate that for clearance delivery, one should contact Albany Approach at 518-862-2299.

Frequencies of Concern

Below are the frequencies that would be used by an aviator utilizing this airfield.

Service	Use	Frequency (MHz)	Location	Distance from 8NY5 (nm)	Hdg/Rad from 8NY5
AWOS-3	Weather	119.225	NY0	13	NW
AWOS-3	Weather	119.275	SCH	10	E
AWOS-3	Weather	132.025	5B2	19	NE

ASOS	Weather	120.45	ALB	16	E
VOR	Navigation	115.3	ALB	15.8	299
VOR	Navigation	115.0	CAM	36.8	268
NDB	Approach	0.523	Johnstown	13.4	157
NDB	Approach	0.356	Hunter	9.7	272
NDB	Approach	0.272	Philmont	38.9	344

Terrain Profile

Below the terrain profile utilizing the proposed wind turbine site as the starting point and the airfield as the end point. The red line indicates the terrain profile. The green line represents Line of Sight. The orange line indicates the Fresnel Zone. If any terrain falls within this zone there is a chance for degradation of a hypothetical source signal (which would be a positive in this case since it would be an unwanted signal potentially being generated by the wind turbine). The terrain profile below does not take into account the height of the wind turbine nor the equipment height at the airport.

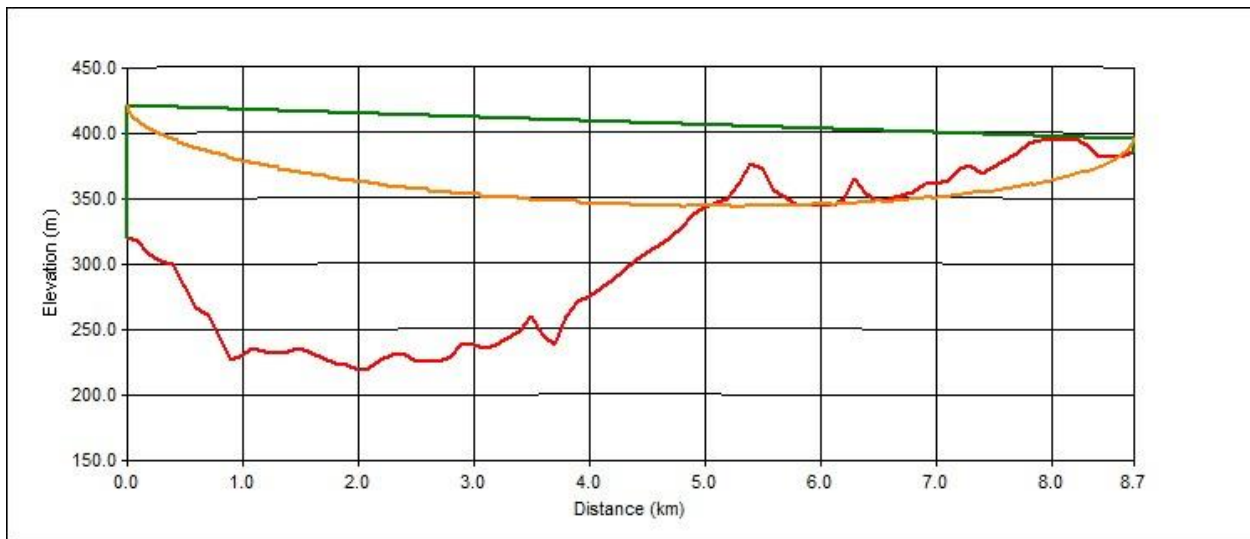

Ranch Airport-3NY0

FAA Data

Ranch Airport is a private airport with the FAA identifier 0NY3, located 3 miles southeast of Ohio, NY with the specific coordinates of 43-18-50.2470N 074-55-55.5640W. The airport's elevation is estimated to be 1440 feet. The airport's zip code is 13324.

The airport is for private use, and prior permission is required before landing. It was activated in November 1974 and does not have a control tower. It is managed by the Boston Center ARTCC

and Buffalo Flight Service Station. It features a wind indicator but doesn't have a segmented circle.

The airport has one runway (13/31) that is 1600 x 100 feet with 300-foot overruns on each end. The surface of the runway is gravel, and it has 40-foot tree obstructions on both ends. The traffic pattern for both runways is to the left.

The radio navigation aids nearby include Johnstown (JJH), located at 320° and 32.4 miles away, operating on a frequency of 523 with a variation of 14W.

The airport is privately owned by Michael S. Kermizian, who is also its manager.

For clearance delivery, Syracuse Approach can be contacted.

Frequencies of Concern

Below are the frequencies that would be used by an aviator utilizing this airfield.

Service	Use	Frequency (MHz)	Location	Distance from 0NY3 (nm)	Hdg/Rad from 0NY3
NDB	Approach	0.523	Johnstown	32.4	320

Terrain Profile

Below the terrain profile utilizing the proposed wind turbine site as the starting point and the airfield as the end point. The red line indicates the terrain profile. The green line represents Line of Sight. The orange line indicates the Fresnel Zone. If any terrain falls within this zone there is a chance for degradation of a hypothetical source signal (which would be a positive in this case since it would be an unwanted signal potentially being generated by the wind turbine). The terrain profile below does not take into account the height of the wind turbine nor the equipment height at the airport.

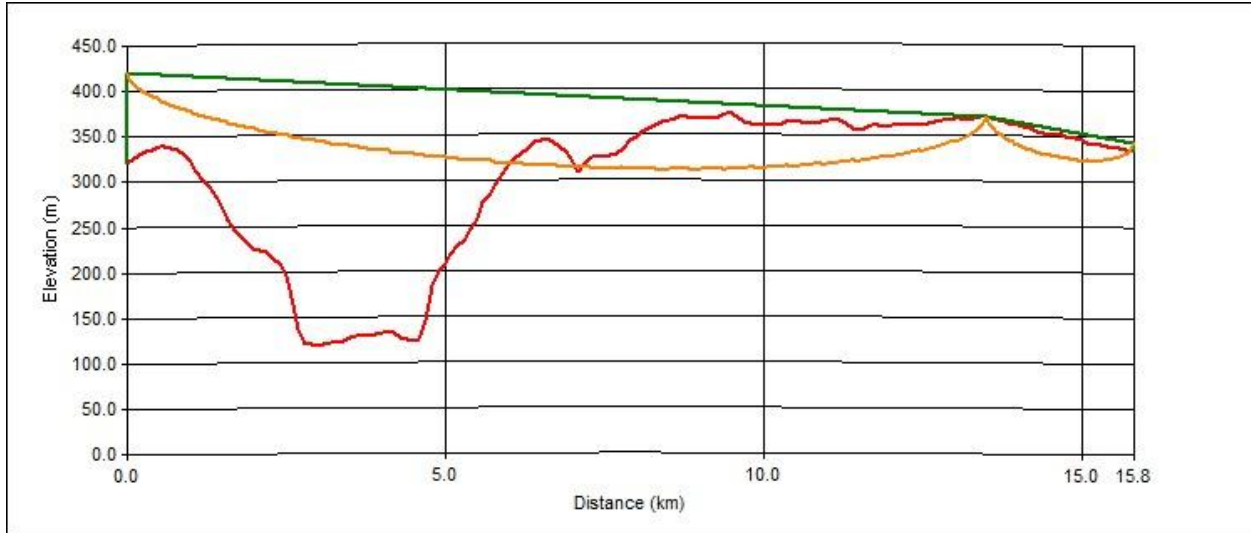

Schenectady County Airport-SCH

FAA Data

Schenectady County Airport is a public airport located 3 miles north of Schenectady, New York. It's identified by the FAA code SCH and has an elevation of 377.9 feet (115.2 meters). The geographical coordinates are 42.8527183N and -73.9295644W. The zip code for the area is 12302.

Airport operations are open to the public with a control tower available. The airport is overseen by the Boston ARTCC and the Burlington Flight Service Station. It also includes facilities such as a wind indicator and lights for visibility.

The airport has two runways, 4/22 and 10/28. Runway 4/22 is 7001 by 150 feet, asphalt/grooved, and in excellent condition, with high-intensity runway edge lights. The 10/28 runway is 4850 by 150 feet, also asphalt/grooved and in good condition, with medium-intensity runway edge lights.

The airport provides various services including fuel (100LL and JET-A), parking facilities (hangars and tiedowns), minor airframe service, and major powerplant service. It does not provide bottled oxygen but does have a low supply of bulk oxygen.

As of the last reporting period ending 30 September 2019, the airport housed 81 aircraft (68 single engine airplanes, 4 multi-engine airplanes, and 9 jets). Daily aircraft operations averaged 134, mostly local general aviation (60%), followed by transient general aviation (30%), military (8%), and air taxi (2%).

The airport is publicly owned by Schenectady County and managed by Michael Shadewald. It also accommodates international operations and requires a landing fee.

Frequencies of Concern

Service	Use	Frequency (MHz)	Location	Distance from 8NY5 (nm)	Hdg/Rad from 8NY5
AWOS-3	Weather	119.225	NY0	20	NW
AWOS-3	Weather	119.275	SCH	-	-
AWOS-3	Weather	132.025	5B2	12	N
ASOS	Weather	120.45	ALB	8	SE
VOR	Navigation	115.3	ALB	8.4	332
VOR	Navigation	115.0	CAM	27.1	266
NDB	Approach	0.523	Johnstown	19.7	130
NDB	Approach	0.356	Hunter	-	-
NDB	Approach	0.272	Philmont	37.1	359
CTAF	Communication	121.3	SCH	-	-
UNICOM	Communication	122.95	SCH	-	-
SCH Ground	Communication	121.9	SCH	-	-
SCH Tower	Communication	121.3	SCH	-	-
SCH Tower	Communication	321.1	SCH	-	-
SCH Tower	Communication	255.4R	SCH	-	-
SCH Tower	Communication	257.8R	SCH	-	-
SCH Tower	Communication	291.6R	SCH	-	-
SCH Tower	Communication	307.2R	SCH	-	-
SCH Tower	Communication	343.7R	SCH	-	-
SCH Tower	Communication	352R	SCH	-	-
SCH Tower	Communication	378.8R	SCH	-	-
ANG OPS	Communication	340.8	SCH	-	-
EMERG	Communication	121.5	SCH	-	-
SVC FM FBO	Communication	122.95	SCH	-	-
ALB Appr	Communication	132.825	ALB	8.4	332
ALB Depart	Communication	132.825	ALB	8.4	332

Terrain Profile

Below the terrain profile utilizing the proposed wind turbine site as the starting point and the airfield as the end point. The red line indicates the terrain profile. The green line represents Line of Sight. The orange line indicates the Fresnel Zone. If any terrain falls within this zone there is

a chance for degradation of a hypothetical source signal (which would be a positive in this case since it would be an unwanted signal potentially being generated by the wind turbine). The terrain profile below does not take into account the height of the wind turbine nor the equipment height at the airport.

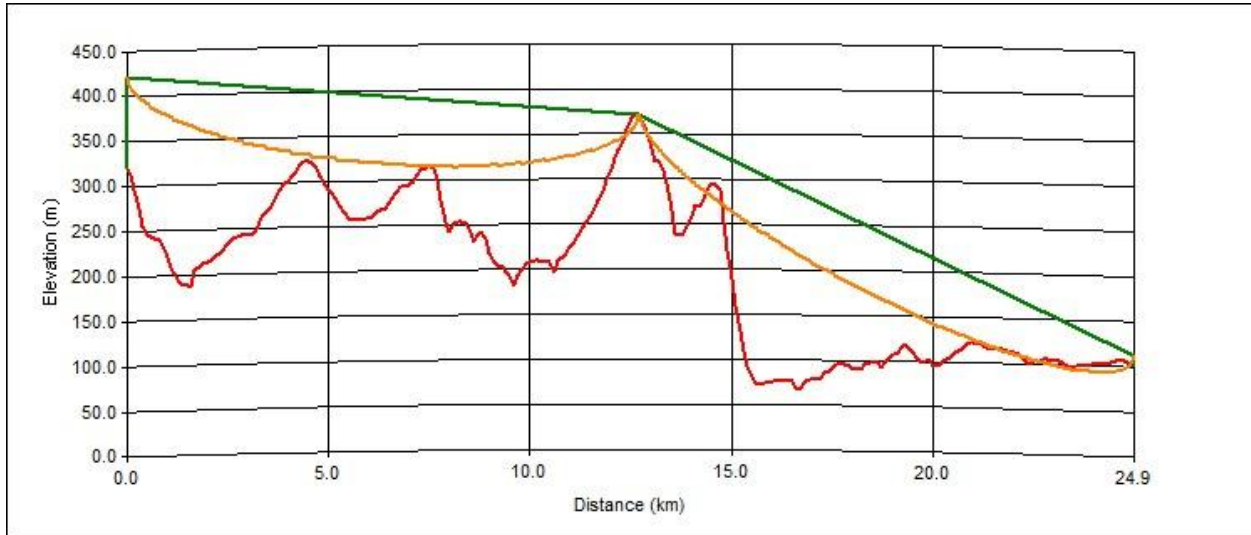

Boston ARTCC

Frequencies of Concern

Frequencies most likely to be used for communication with Boston ARTCC are listed below:

Lake George, NY RCAF

Frequency	Type	Tone	Alpha Tag	Description	Mode	Tag
121.350	BM	CSQ	ZBW22 ALB-L	Sector 22 Albany Low 11,000-FL230	AM	Aircraft
128.325	BM	CSQ	ZBW39 CAM-H	Sector 39 Cambridge High FL240-600	AM	Aircraft
135.325	BM	CSQ	ZBW38 AHN-H	Sector 38 Athens High FL240-600	AM	Aircraft
257.850	BM		ZBW22 ALB-L	Sector 22 Albany Low 11,000-FL230	AM	Aircraft
348.700	BM		ZBW39 CAM-H	Sector 39 Cambridge High FL240-600	AM	Aircraft

360.600		BM		ZBW38 AHN-H	Sector 38 Athens High FL240-600	AM	Aircraft
---------	--	----	--	-------------	------------------------------------	----	----------

Remsen, NY RCAG

Frequency		Type	Tone	Alpha Tag	Description	Mode	Tag
124.125		BM	CSQ	ZBW10 High	Sector 10 Rockdale High FL280-600	AM	Aircraft
273.550		BM		ZBW10 High	Sector 10 Rockdale High FL280-600	AM	Aircraft

Rockdale, NY RCAG

Frequency		Type	Tone	Alpha Tag	Description	Mode	Tag
127.375		BM	CSQ	ZBW24 High	Sector 24 Delancey High FL180-270	AM	Aircraft
133.250		BM	CSQ	ZBW23 Low	Sector 23 Hancock Low SFC-17,000	AM	Aircraft
279.500		BM		ZBW23 Low	Sector 23 Hancock Low SFC-17,000	AM	Aircraft
353.925		BM		ZBW24 High	Sector 24 Delancey High FL180-270	AM	Aircraft

Albany International Airport-ALB

Albany International Airport is the closest airfield to the wind turbine site that has an Airport Surveillance Radar (ASR-9). ASR systems at large airports share service with all nearby local airports.

The ASR-9 stands as the inaugural airport surveillance radar that could simultaneously detect meteorological phenomena and aircraft using the same beam, and visually represent both on a single display. Equipped with a digital Moving Target Detection (MTD) processor, it employs Doppler radar technology in tandem with a clutter map. This sophisticated combination enables it to filter out ground and weather interference and track targets with improved efficiency. Theoretically, the ASR-9 has the capacity to track up to 700 aircraft concurrently.

The radar's klystron tube transmitter works in the S-band spectrum, oscillating between 2.5 and 2.9 GHz, and uses circular polarization. It exhibits a peak power output of 1.3 MW, a pulse duration of 1 microsecond, and a pulse repetition frequency that ranges from 325 to 1200

pulses per second. If the primary frequency faces interference, it can be switched to a backup frequency. The radar's receiver demonstrates a high sensitivity, capable of detecting a radar cross-section of 1 square meter from a distance of 111 kilometers, and provides a range resolution of 450 feet.

The radar's antenna can cover an elevation of 40° from the horizon and uses two feedhorns, which generate two vertically stacked, overlapping lobes with a 4° separation. The lower beam sends the outgoing pulse and is utilized for the detection of faraway targets near the horizon, while the higher beam, which is receive-only, identifies closer aircraft at higher elevations with reduced ground clutter. The antenna offers a gain of 34 dB and a beamwidth of 5° in elevation and 1.4° in azimuth. With a rotational speed of 12.5 RPM, the antenna scans the surrounding airspace every 4.8 seconds.

The system's electronics operate on a dual-channel basis and are designed for fault tolerance. The ASR-9 features a remote monitoring and maintenance subsystem which, in case of any malfunction, activates an integrated test that detects and isolates the issue. Consistent with other airport surveillance radars, the ASR-9 is equipped with a backup diesel generator to ensure uninterrupted operation during power outages.

Frequencies of Concern

The radar operates on frequencies of 2.5-2.9 GHz. The distance and terrain between the wind turbine and ALB is sufficient enough to not consider any impact to the communication frequencies used by Albany International Airport.

Radar Clutter Interference

If the proposed wind turbine is over 200 feet tall it will require a Federal Aviation Administration (FAA) Obstruction Evaluation / Airport Airspace Analysis (OE/AAA).

The FAA has regulatory jurisdiction over structures that exceed 200 feet above ground level, including utility-scale wind turbines, ensuring their compatibility with aviation safety and other airspace uses, including radar. Developers are obligated to lodge an application via the FAA's Obstruction Evaluation/Airport Airspace Analysis process. This evaluates the likelihood of radar interference emanating from the proposed wind farm. In tandem with this, the FAA alerts other federal departments with radar facilities in proximity to the planned project (DOD, DHS, and NOAA), enabling them to assess potential impacts.

The DOD Military Aviation and Installation Assurance Siting Clearinghouse brings together feedback from different DOD branches, offices, and bases to evaluate potential effects on their operations.

The DOD Siting Clearinghouse follows a systematic, formal review procedure to carry out compatibility assessments for proposed wind projects submitted to the FAA. An informal review process has been set up by the Clearinghouse to expedite these assessments, advising developers to seek a preliminary verdict before lodging an application with the FAA. This informal review facilitates a swift, transparent, and evidence-based analysis of potential project impacts, flagging potential concerns to project developers and federal agencies before entering the formal FAA review phase. If issues are identified, the Clearinghouse collaborates with the industry to resolve these, if possible, mitigating national security risks whilst endorsing harmonious domestic energy development.

Apart from the FAA process, NOAA has its own preliminary review process, details of which are available on its Radar Operations Center website.

Developers can utilize online tools for preliminary site screenings prior to liaising with federal agencies. These include the DOD Preliminary Screening Tool, the NOAA NEXRAD Screening Tool (incorporating the U.S. Wind Turbine Database), and the DOD Siting Clearinghouse.

Developers are required to file a notice 90 to 120 days before intended construction. Proposals must include individual turbine specifications (including latitude/longitude and overall turbine height) as well as the project layout at the time of filing.

If a project is found to potentially negatively impact, for instance, DOD military readiness (research, development, testing, and evaluation, training, and military operations) or DHS interests, these agencies partner with wind farm developers to identify mitigation strategies. The DOD Siting Clearinghouse has assessed approximately 10,000 energy projects since 2010 for potential impacts on military operations, with only a single case where discrepancies could not be reconciled.

The concern over the wind turbine creating Radar clutter will be studied thoroughly by United States Federal Government entities to ensure there will be no degradation of service.

“RF Sinking”

The concept of an "RF sinking" has been referenced, but is not recognized as a formal term or concept in the field of electronics or radio frequency technology.

The term "RF sinking" might be a misunderstanding or misinterpretation of certain concepts in radio frequency technology. Radio frequencies are not something that can be physically 'sunk' or absorbed in the same way that heat can be absorbed by a heat sink. Instead, RF energy travels through space and can be received, transmitted, refracted, or reflected by various devices and substances, but not 'sunk'.

Until there's an established and widely accepted definition of an "RF sink" in the radio frequency or electronic field, it remains an unclear and undefined term.

TEST DETAILS - PRE-CONSTRUCTION SURVEY

Test Equipment

Keysight FieldFox Spectrum Analyzer N9914A

Keysight's FieldFox Handheld RF and Microwave Analyzers are portable, rugged devices designed to meet the demands of field testing modern communication networks. These analyzers offer over 25 software-enabled measurement capabilities in a single unit, providing precision equivalent to benchtop results.

According to the manufacturer, key features include:

- Different configurations as a cable and antenna analyzer (CAT), handheld vector network analyzer (VNA), handheld spectrum analyzer, or an all-in-one combination analyzer.
- Frequency coverage up to 6.5 GHz and wide analysis bandwidth.
- Capabilities to capture interfering signals with wideband, real-time analysis.
- The FieldFox RF Analyzer Software includes various applications for spectrum analysis, cable and antenna testing, 5G/LTE field testing, power measurements, indoor and outdoor mapping, and more.

These analyzers are suitable for various applications including RF cable troubleshooting, over-the-air wireless communications, analog radio, and electromagnetic interference pre-compliance testing. The company also offers bundled solutions tailored for different sectors like Aerospace and Defense, Wireless Communication, and General Purpose applications.

Other offerings include a video course on 5G field tests, a series on RF development and deployment challenges, and the Keysight Spectrum Monitoring Software (KSMS). An emerging feature is the Time Difference of Arrival (TDOA) technique, which allows multiple FieldFox analyzers to locate an unknown signal source.

See Data Sheet for the Keysight FieldFox N9914A Spectrum Analyzer in Appendix.

Keysight N6850A Broadband Omnidirectional Antenna

Keysight Technologies' N6850A Broadband Omnidirectional Antenna is a passive antenna designed for a range of applications such as spectrum monitoring, interference detection, and signal location. It is suitable for various operations including fixed-site, vehicle-mounted, and

handheld use, and is compatible with devices such as the N6841A RF Sensor, N99XX handheld spectrum analyzers, and other spectrum analyzers or receivers.

The N6850A Antenna is designed to cover the full frequency range up to 6 GHz, eliminating the need for multiple antennas and allowing for more efficient mounting and transportation. Its low profile and uniform gain pattern make it suitable for inconspicuous spectrum monitoring applications and geolocation techniques.

Key features include a wide frequency range covering 20 MHz to 6 GHz, a uniform gain pattern, and a mounting adapter suitable for various types of mounting, including post, rail, handheld, and vehicle mounting. The compact design allows for easy transportation and mounting, and it offers low wind loading, making it ideal for signal monitoring from towers or vehicles.

Specifications for the N6850A antenna include a frequency range of 20 MHz to 6 GHz, vertical polarization, 50-ohm impedance, and a VSWR of less than 2.5 for 450 MHz to 6 GHz. It is designed to withstand temperatures from -50 to +70°C and wind speeds of up to 100 miles/hr (160 km/hr). The antenna is ROHS compliant, with an IP67 ingress rating, and weighs approximately 1.15 kg. The mounting bracket adds another 1.54 kg, and the shipping weight is approximately 6.1 kg.

See Data Sheet for the Keysight N6850A Broadband Omnidirectional Antenna in Appendix.

Moonraker Ltd X1 HF Vertical Receive Antenna

The Moonraker Ltd X1 HF Vertical Receive Antenna, Manufacturer's Part Number: 11-510, is designed for shortwave listening in areas with limited space for larger antennas. These HF (High Frequency) Receive Antennas utilize internally loaded wire traps and provide a RX capability ranging from 1-50 MHz, eliminating the need for radials.

Additional product details are as follows:

- The antenna stands 6.562 feet or 200 cm tall.
- It uses a UHF SO-239 connector.
- Single whip design

Narda NBM-550 / EA5091

The Narda Broadband Field Meter NBM-550, part of the NBM-500 family, is a precision measurement device used for detecting non-ionizing radiation. The device employs probes to measure electric and magnetic field strengths, covering frequencies ranging from a few Hz found in industrial applications up to microwave radiation. It utilizes flat and shaped probes, the latter of which assess field strength based on human safety standards. The probes, calibrated

separately, have an in-built non-volatile memory for parameters and calibration data, hence they can be utilized with any NBM-500 device while retaining their calibration accuracy.

The NBM-550 is primarily used for ensuring human safety in environments with high electric or magnetic field strengths. Applications include complying with safety regulations, establishing safe zones, measuring and monitoring field strengths around electronic equipment like broadcasting, radar, cell phone transmitters, satellite systems, industrial equipment, and medical devices that generate high-frequency radiation. The device can also measure static magnetic fields in industry and medicine.

The device is designed for on-site use and provides accurate results under various conditions. Features include a graphical user interface with selectable language, backlit monochrome LCD, multiple result display options, a history mode, and selectable units. It also automatically adjusts and applies calibration data, offers special evaluation options like time and spatial averaging, and includes a warning function for programmable alarm thresholds and hot spot searches. The measuring tool is part of the NBM-500 family and can shape frequency to align with various international safety standards, including those set by the ICNIRP, FCC, IEEE, and Safety Code 6. The results of these measurements are directly shown as a percentage of the standard used.

The EA9051 probe makes isotropic, or non-directional, measurements. The probe contains six dipoles, a mix of diode-based and thermocouple-based ones. The overlapping of two properly tuned dipoles, with one acting as a high pass filter and the other as a low pass filter, mirrors a certain frequency sensitivity for compliance testing.

Applications for this tool include detecting electric fields from 300 kHz to 50 GHz in environments with telecom transmitters, mobile phones, and broadcasting.

The probes are calibrated at several frequencies and automatically account for correction values, which are stored in an EPROM within the probe. The calibration ensures accurate results irrespective of the probe and instrument combination used. The specifications include a frequency range of 300 kHz to 50 GHz, a dynamic range of 3850 $\mu\text{dWB}/\text{cm}^2$ to 500 mW/cm^2 , and an isotropic response.

Narda SRM-3000

The Narda SRM-3000 is a fast and frequency-selective measurement tool. Areas with dense communication needs have a limited space for antennas and also need to adhere to electromagnetic emission limits.

In cases where emission limits are exceeded, both operators and authorities need to identify the major components of the electromagnetic radiation. Broadband orientation measurements are used to locate areas of highest field strength. If the emission limit is exceeded, selective measurements are taken to identify and measure known sources.

Narda also provides solutions for long term monitoring of field strength and radiation levels. Its product, the SRM, is a frequency-selective, precision measuring instrument that is easy to use and portable, making it ideal for telecoms, mobile phone providers, measurement services, and authorities. It can measure from VHF to UMTS frequencies and is designed to withstand harsh conditions, from heat to snow. It can be updated with new standards and evaluation curves for safety measurements as they are published.

Isotropic antennas measure in three mutually perpendicular axes and are usually connected to the SRM. Despite their anisotropy (deviation from perfect isotropy), they offer satisfactory performance for most measurements, even when handheld. For more precise measurements, they can be mounted on a tripod and connected to the SRM via cable to minimize effects of reflections from the instrument casing and the person conducting the measurement.

The frequency range is 75 MHz to 3 GHz, and the system enables fast, non-directional measurements.

Onelinkmore RF Coaxial Adapter Connector Kit N Female to UHF PL-259 SO-239 Male Straight Adapter

The onelinkmore RF coaxial adapter is compatible with the Extension Cable Antenna CCTV include connectors of various types, such as UHF, N, and Coaxial. These connectors are offered in diverse gender configurations which comprise Female-to-Female, Female-to-Male, and Male-to-Male. The inner needle is brass gold plated.

The package incorporates several RF Coaxial Connector Adapters, including N Type Male to UHF Male, N Type Male to UHF Female, N Type Female to UHF Male, and N Type Female to UHF Female.

This product boasts a broad range of applications, thanks to its swift connect/disconnect feature and dependable lock, among others. It is particularly useful for projects that require N Type and UHF connectors, such as those involving antennas, telecom, coaxial cables, LMR, CCTV, microwave applications, and digital communication systems.

This adapter is durable and offers enhanced transmission efficiency. This is attributed to the nickel-plated brass connector body and the pure brass contactor, which also serve as protective measures for your device interface during frequent changes.

WaveControl SMP2 / WP400

The SMP2 Field Meter is a versatile and comprehensive instrument, boasting three primary features: spectrum analysis ranging from Direct Current (DC) to 400 kHz, broadband measurements (DC - 60 GHz), and static field measurements. Its high-tech functionality

includes real-time spectrum analysis through Fast Fourier Transform (FFT) digital processing. This versatile tool also integrates the Weighted Peak Method (WPM), which allows automatic and real-time comparison with set limits. The SMP2 also contains a special auto-gain function designed for peak detection, proving invaluable for tasks such as welding.

The field meter boasts a multitude of display options and functions. It presents results in both Root Mean Square (RMS) and peak values, and offers a unique function for time-domain measurement of specific frequencies. Other display capabilities include automatic field probe recognition, E&H field selection, and detailed values for total field as well as each component (X, Y, Z). Furthermore, it allows for frequency SPAN selection, and incorporates high pass filters at 1 Hz, 10 Hz, 25 Hz, and 100 Hz.

In addition to these features, the SMP2 also supports max-hold and spatial average functions, and displays maximum, minimum, and average values. It offers a sliding window function conforming to various standards and allows for adjustable measurement times from as little as 1 second to as much as 100 hours. You can also program the measurement to start at a particular time.

The graphical interface of the SMP2 displays broadband measurement changes over time and allows for graph display adjustments from 1 second to 12 minutes. For alerting users, a programmable alarm function is integrated. Moreover, this field meter includes both USB and fiber optics connections, enhancing its connectivity capabilities.

Storage capacity is abundant with the SMP2, allowing extensive data recording. It features a screen-shot function that's perfect for reporting. Moreover, it comes with PC software to control the device and generate reports. The device can automatically upload results to a web-page control center for easy access and review. Available in multiple languages, the SMP2 Field Meter offers universal utility.

The WP400 Probe is designed to measure both electric and magnetic fields across a frequency range of 1 Hz to 400 kHz. It provides isotropic and true RMS measurements and is used for spectrum analysis. The probe meets international standards and features a sensor with a surface area of 100 cm².

The probe can be used in a variety of environments. It is capable of assessing the exposure to electromagnetic (EM) fields at power grids, including transformer stations and high-voltage lines. It can also measure the EM fields in trains and in the railway environment concerning human exposure, and assess workers' exposure to EM fields in manufacturing facilities.

The WP400 has two main modes: Field Strength Mode and FFT Mode. In the Field Strength Mode, the measurement range for the electric field is from 1 V/m to 100 kV/m and for the magnetic field is from 50 nT - 30 mT @ 50 Hz and 50 nT - 10 mT (100 Hz - 10 kHz). In the FFT Mode, the measurement range for the electric field is from 4 mV/m to 100 kV/m and for the magnetic field is from 0.5 nT - 30 mT @ 50 Hz and 0.5 nT - 10 mT (100 Hz - 10 kHz). The probe

provides various displays such as RMS, Axis Values, AVG, MAX, MIN, PEAK, RMS time graph, and Frequency analysis.

It adheres to several standards and limits including EU Directive 2013/35/EU, IEEE, ICNIRP, and BGV B11. It also allows for easy software updates for future modifications and other limits.

XRDS -RF KMR240 N Male Cable (10 feet)

The XRDS KMR240 is a 10-foot long coaxial cable with N-Male to N-Male connectors, featuring an ultra-low-loss design. The cable is black in color and constructed to minimize signal loss during transmission. It has a signal loss of only 0.42 dB per 3 feet on 3000MHz frequencies. The N-Male connectors are present on both ends of the cable, allowing for easy and secure connections. This cable ensures efficient signal transfer over long distances with minimal loss.

The inner conductor of this cable is made of solid copper, ensuring high efficiency and reduced signal loss compared to cheap copper clad aluminum alternatives. The cable is also heavy-duty, providing durability and longevity. The jacket surrounding the cable is made of flexible PVC that is resistant to water and suitable for use in harsh outdoor environments.

Our N Male to N Male cable features a black heat shrink tube with lined adhesive, which is applied using heat shrinking technology to connect the adapter and the coaxial cable. This construction ensures a secure and reliable connection. Furthermore, the cable length is up to 2.2 inches, longer than other cables, which prevents the cable from coming off easily.

XRDS-RF is a reputable manufacturer specializing in the production of coaxial cables. This N to N jumper cable undergoes testing using USA KEYSIGHT E5071C ENA network analyzers to ensure a VSWR (Voltage Standing Wave Ratio) of less than 1.1. XRDS-RF is dedicated to enhancing the lives of our customers, and this cable exemplifies our commitment to unmatched product quality.

Test Locations

Due to the dense vegetation around the proposed wind turbine site we were limited to hewn access paths to the site, gas pipeline paths, and roads as test locations. Additionally, we were granted access to a nearby resident's property and we used this as a test location as well.

Below are approximate locations of our test points. The data for the Keysight Spectrum Analyzer and the WaveControl meter contain precise GPS coordinates for all test locations.

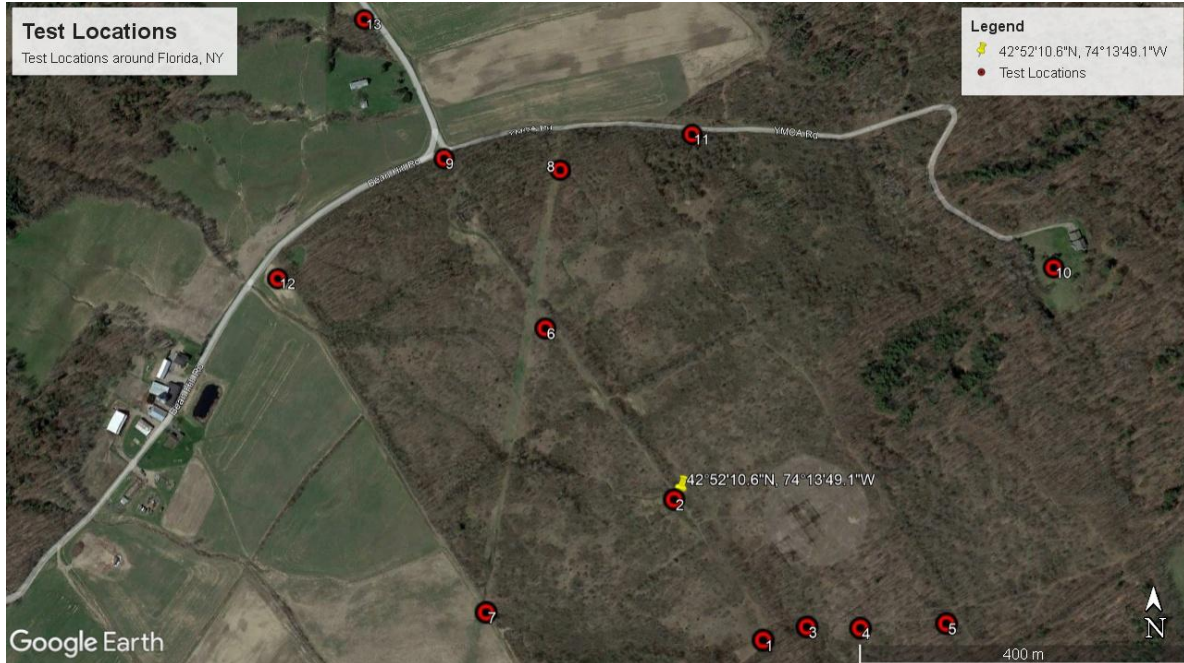

Test Procedure

Broadband Low Frequency Measurements (1Hz-400kHz)

We wanted to capture the entirety of the RF environment at various points around the proposed turbine to get a high level view of changes that the Wind Turbine might make. To accomplish this we utilized the WaveControl SMP2/WP400 Probe (1Hz-400kHz). The procedure is listed below:

1. Ensure the WaveControl meter is set to Occupational Exposure measurement protocol (6 minute log time), name measurement point as log name.
2. Step away from the meter to ensure there is no RF coupling between the user and the antenna.
3. Logging ends automatically on the WaveControl meter.
4. Repeat for the seven other measurement locations.

Broadband High Frequency Measurements (300 kHz-50GHz)

We wanted to capture the entirety of the RF environment at various points around the proposed turbine to get a high level view of changes that the Wind Turbine might make. To accomplish this we will utilize the Narda NBM-550/EA5091 Probe (300 kHz-50GHz). The procedure is listed below:

1. Ensure the Narda meter is set to record the maximum RF signal strength (Max Hold

feature)

Narrowband Measurements

To address concerns of interfering signals being generated by the wind turbine we take a more defined approach to characterize the RF environment before and after the construction of the wind turbine. Starting at the proposed base of the turbine we will do the following:

1. Ensure the Spectrum Analyzer's Preamplifier is turned on.
2. Ensure the Spectrum Analyzer's Attenuation is turned to 0dB.
3. Ensure the Spectrum Analyzer's Interference Analysis (Spectrogram) feature is turned on.
4. Ensure the Spectrum Analyzer's Max Hold function is on.
5. Preset the following Bandwidth Frequencies to capture all frequencies of concern:
 - a. 1.0-50 MHz
 - b. 110-140 MHz
 - c. 250-400 MHz
 - d. 2.4-3.0 GHz
6. Use Spectrum Analyzer "marker" feature to highlight center frequencies of frequencies of concern.
 - a. 115.0 MHz
 - b. 115.3 MHz
 - c. 119.225 MHz
 - d. 119.275 MHz
 - e. 120.45 MHz
 - f. 132.025 MHz
 - g. 255.4 MHz
 - h. 291.6 MHz
 - i. 307.2 MHz
 - j. 321.1 MHz
 - k. 352.0 MHz
 - l. 378.8 MHz
7. Starting at the base of the proposed turbine log data at the 4 bandwidths shown above.
8. Move to other test locations around the proposed site.

High Resolution Measurements

To address concerns of interfering signals being generated by the wind turbine we take a more defined approach to characterize the RF environment before and after the construction of the wind turbine. Starting at the proposed base of the turbine we will do the following:

1. Ensure the Spectrum Analyzer's Preamplifier is turned on.
2. Ensure the Spectrum Analyzer's Attenuation is turned to 0dB.
3. Ensure the Spectrum Analyzer's modulation feature is turned on.

4. Preset the following Bandwidth Frequencies to capture all frequencies of concern:

Amateur (Modes both AM & FM)

High Frequency

- a. 1.85 Mhz
- b. 3.85 MHz
- c. 7.250 MHz
- d. 14.250 MHz
- e. 18.250 MHz
- f. 21.250 MHz
- g. 28.500 MHz

Very High Frequency

- h. 147.00 MHz
- i. 225.00 MHz

Ultra High Frequency

- j. 440.00 MHz

Public Service (Mode FM)

- k. 155.00 MHz
- l. 453.00 MHz
- m. 800.00 MHz

5. Ensure the measurement bandwidth is set to 100 Hz.
6. Starting at the base of the proposed turbine log data in AM/FM modes for the above frequencies.
7. Move to two other test locations (Point 2 & 13) around the proposed site.

Weather Data

Weather significantly influences radio frequency signal propagation. Rain can absorb RF signals, causing signal attenuation, primarily at higher frequencies - a phenomenon known as rain fade. Atmospheric pressure changes impact air density, affecting RF signal speed and strength. Air temperature affects the refractive index, leading to signal bending or refraction, and in cases of temperature inversion, it can cause increased range but potential system interference. Humidity can lead to RF energy absorption, and wind, while not directly influencing RF signals, can introduce obstacles or alter antenna alignment. Snow, ice, and even fog and clouds can cause signal loss, especially at higher frequencies. It's crucial to note that these effects are frequency-dependent, with lower frequencies generally being less impacted than higher ones. Below is the data from the test days.

Monday June 12th, 2023

Time	Temperature	Dew Point	Humidity	Wind	Wind Speed	Wind Gust	Pressure	Precip.	Condition
12:51 AM	72 °F	54 °F	53 %	SE	5 mph	0 mph	29.51 in	0.0 in	Cloudy
1:51 AM	70 °F	54 °F	57 %	CALM	0 mph	0 mph	29.51 in	0.0 in	Cloudy
2:51 AM	71 °F	55 °F	57 %	SE	5 mph	0 mph	29.50 in	0.0 in	Cloudy
3:51 AM	68 °F	56 °F	65 %	ESE	5 mph	0 mph	29.49 in	0.0 in	Cloudy
4:51 AM	66 °F	58 °F	75 %	CALM	0 mph	0 mph	29.50 in	0.0 in	Cloudy
5:51 AM	65 °F	60 °F	84 %	CALM	0 mph	0 mph	29.50 in	0.0 in	Light Drizzle
6:51 AM	65 °F	60 °F	84 %	CALM	0 mph	0 mph	29.50 in	0.0 in	Mostly Cloudy
7:51 AM	69 °F	61 °F	75 %	CALM	0 mph	0 mph	29.50 in	0.0 in	Mostly Cloudy
8:51 AM	72 °F	60 °F	66 %	SE	6 mph	0 mph	29.49 in	0.0 in	Cloudy
9:51 AM	73 °F	60 °F	64 %	SSE	8 mph	0 mph	29.48 in	0.0 in	Cloudy
10:51 AM	76 °F	61 °F	60 %	SSE	7 mph	16 mph	29.47 in	0.0 in	Cloudy
11:51 AM	81 °F	62 °F	52 %	SE	14 mph	20 mph	29.46 in	0.0 in	Mostly Cloudy
12:51 PM	83 °F	63 °F	51 %	S	15 mph	22 mph	29.44 in	0.0 in	Mostly Cloudy
1:51 PM	80 °F	61 °F	52 %	S	9 mph	18 mph	29.42 in	0.0 in	Cloudy
2:51 PM	83 °F	55 °F	38 %	SE	16 mph	25 mph	29.40 in	0.0 in	Mostly Cloudy
3:51 PM	84 °F	53 °F	34 %	SSE	17 mph	23 mph	29.37 in	0.0 in	Mostly Cloudy
4:51 PM	81 °F	53 °F	38 %	SE	13 mph	23 mph	29.36 in	0.0 in	Mostly Cloudy
5:51 PM	80 °F	54 °F	40 %	SE	10 mph	20 mph	29.35 in	0.0 in	Mostly Cloudy
6:51 PM	78 °F	56 °F	46 %	ESE	9 mph	0 mph	29.36 in	0.0 in	Mostly Cloudy
7:51 PM	77 °F	55 °F	46 %	ESE	8 mph	0 mph	29.36 in	0.0 in	Cloudy
8:51 PM	75 °F	55 °F	50 %	ESE	8 mph	0 mph	29.35 in	0.0 in	Light Rain
9:51 PM	75 °F	54 °F	48 %	ESE	6 mph	0 mph	29.34 in	0.0 in	Cloudy
10:51 PM	72 °F	57 °F	59 %	ESE	13 mph	0 mph	29.33 in	0.0 in	Cloudy
11:51 PM	71 °F	58 °F	63 %	E	6 mph	0 mph	29.31 in	0.0 in	Cloudy

Tuesday June 13th, 2023

Time	Temperature	Dew Point	Humidity	Wind	Wind Speed	Wind Gust	Pressure	Precip.	Condition
12:51 AM	70 °F	60 °F	71 %	ESE	3 mph	0 mph	29.28 in	0.0 in	Cloudy
1:25 AM	67 °F	62 °F	84 %	CALM	0 mph	0 mph	29.27 in	0.0 in	Rain
1:51 AM	67 °F	62 °F	84 %	NNW	5 mph	0 mph	29.26 in	0.0 in	Light Rain
2:13 AM	65 °F	62 °F	90 %	WNW	3 mph	0 mph	29.27 in	0.0 in	Rain
2:19 AM	65 °F	62 °F	90 %	NW	3 mph	0 mph	29.27 in	0.1 in	Rain
2:51 AM	65 °F	62 °F	90 %	NW	5 mph	0 mph	29.27 in	0.2 in	Rain
2:58 AM	65 °F	62 °F	90 %	NW	5 mph	0 mph	29.27 in	0.0 in	Rain
3:05 AM	65 °F	62 °F	90 %	NW	6 mph	0 mph	29.27 in	0.0 in	Rain
3:40 AM	65 °F	63 °F	93 %	CALM	0 mph	0 mph	29.28 in	0.1 in	Light Rain
3:51 AM	65 °F	63 °F	93 %	CALM	0 mph	0 mph	29.28 in	0.1 in	Light Rain
4:18 AM	65 °F	63 °F	93 %	CALM	0 mph	0 mph	29.28 in	0.0 in	Light Drizzle
4:31 AM	66 °F	63 °F	90 %	SSW	5 mph	0 mph	29.29 in	0.0 in	Light Drizzle
4:51 AM	61 °F	58 °F	90 %	W	10 mph	23 mph	29.30 in	0.0 in	Light Rain
5:02 AM	61 °F	58 °F	90 %	W	10 mph	0 mph	29.31 in	0.0 in	Cloudy
5:28 AM	61 °F	56 °F	83 %	W	15 mph	22 mph	29.32 in	0.0 in	Cloudy
5:51 AM	60 °F	56 °F	86 %	W	12 mph	0 mph	29.32 in	0.0 in	Cloudy
6:29 AM	60 °F	55 °F	83 %	W	22 mph	26 mph	29.34 in	0.0 in	Cloudy / Windy
6:51 AM	60 °F	55 °F	83 %	W	20 mph	0 mph	29.36 in	0.0 in	Mostly Cloudy
7:51 AM	61 °F	55 °F	81 %	W	13 mph	0 mph	29.38 in	0.0 in	Cloudy
8:51 AM	63 °F	54 °F	72 %	WSW	13 mph	21 mph	29.40 in	0.0 in	Mostly Cloudy
9:51 AM	64 °F	54 °F	70 %	WSW	12 mph	0 mph	29.40 in	0.0 in	Mostly Cloudy
10:51 AM	66 °F	54 °F	65 %	WSW	13 mph	0 mph	29.41 in	0.0 in	Mostly Cloudy
11:39 AM	70 °F	54 °F	57 %	W	13 mph	0 mph	29.40 in	0.0 in	Mostly Cloudy
11:51 AM	69 °F	53 °F	57 %	W	14 mph	0 mph	29.40 in	0.0 in	Mostly Cloudy
12:51 PM	70 °F	53 °F	55 %	W	9 mph	0 mph	29.40 in	0.0 in	Mostly Cloudy
1:51 PM	71 °F	54 °F	55 %	W	8 mph	0 mph	29.39 in	0.0 in	Mostly Cloudy
2:51 PM	72 °F	52 °F	49 %	CALM	0 mph	0 mph	29.37 in	0.0 in	Mostly Cloudy
3:51 PM	75 °F	54 °F	48 %	NNW	7 mph	0 mph	29.35 in	0.0 in	Mostly Cloudy
4:51 PM	76 °F	54 °F	46 %	NW	6 mph	0 mph	29.34 in	0.0 in	Mostly Cloudy
5:51 PM	73 °F	51 °F	46 %	NNW	3 mph	0 mph	29.35 in	0.0 in	Mostly Cloudy
6:51 PM	73 °F	51 °F	46 %	N	3 mph	0 mph	29.35 in	0.0 in	Mostly Cloudy
7:51 PM	71 °F	50 °F	47 %	NW	3 mph	0 mph	29.36 in	0.0 in	Mostly Cloudy
8:51 PM	68 °F	53 °F	59 %	W	3 mph	0 mph	29.37 in	0.0 in	Mostly Cloudy
9:51 PM	67 °F	52 °F	59 %	CALM	0 mph	0 mph	29.37 in	0.0 in	Mostly Cloudy
10:51 PM	62 °F	52 °F	70 %	CALM	0 mph	0 mph	29.36 in	0.0 in	Partly Cloudy
11:51 PM	58 °F	53 °F	84 %	CALM	0 mph	0 mph	29.35 in	0.0 in	Fair

Wednesday June 14th, 2023

Time	Temperature	Dew Point	Humidity	Wind	Wind Speed	Wind Gust	Pressure	Precip.	Condition
12:51 AM	58 °F	52 °F	81 %	CALM	0 mph	0 mph	29.34 in	0.0 in	Fair
1:51 AM	56 °F	52 °F	87 %	S	3 mph	0 mph	29.34 in	0.0 in	Fair
2:51 AM	56 °F	52 °F	87 %	CALM	0 mph	0 mph	29.34 in	0.0 in	Fair
3:51 AM	55 °F	51 °F	86 %	CALM	0 mph	0 mph	29.33 in	0.0 in	Fair
4:51 AM	54 °F	51 °F	90 %	CALM	0 mph	0 mph	29.32 in	0.0 in	Fair
5:00 AM	54 °F	51 °F	90 %	CALM	0 mph	0 mph	29.32 in	0.0 in	Fair
5:51 AM	53 °F	51 °F	93 %	CALM	0 mph	0 mph	29.31 in	0.0 in	Patches of Fog
6:51 AM	57 °F	53 °F	87 %	CALM	0 mph	0 mph	29.30 in	0.0 in	Patches of Fog
7:51 AM	60 °F	55 °F	83 %	VAR	3 mph	0 mph	29.30 in	0.0 in	Patches of Fog
8:51 AM	64 °F	52 °F	65 %	SE	7 mph	0 mph	29.29 in	0.0 in	Mostly Cloudy
9:51 AM	67 °F	52 °F	59 %	S	8 mph	0 mph	29.27 in	0.0 in	Mostly Cloudy
10:51 AM	70 °F	55 °F	59 %	NE	5 mph	0 mph	29.24 in	0.0 in	Mostly Cloudy
11:51 AM	73 °F	54 °F	51 %	SE	3 mph	0 mph	29.21 in	0.0 in	Cloudy
12:51 PM	72 °F	53 °F	51 %	SSE	10 mph	0 mph	29.20 in	0.0 in	Cloudy
1:51 PM	70 °F	54 °F	57 %	S	10 mph	0 mph	29.20 in	0.0 in	Light Rain
2:51 PM	66 °F	57 °F	73 %	ESE	9 mph	0 mph	29.19 in	0.0 in	Light Rain
3:51 PM	63 °F	58 °F	84 %	ESE	9 mph	0 mph	29.18 in	0.0 in	Light Rain
4:51 PM	62 °F	58 °F	86 %	E	7 mph	0 mph	29.16 in	0.1 in	Light Rain
5:49 PM	63 °F	57 °F	82 %	E	3 mph	0 mph	29.16 in	0.0 in	Mostly Cloudy
5:51 PM	64 °F	58 °F	80 %	VAR	5 mph	0 mph	29.15 in	0.0 in	Mostly Cloudy
6:23 PM	64 °F	58 °F	80 %	ESE	3 mph	0 mph	29.15 in	0.0 in	Mostly Cloudy
6:46 PM	64 °F	57 °F	77 %	E	3 mph	0 mph	29.14 in	0.0 in	Mostly Cloudy
6:51 PM	64 °F	58 °F	80 %	E	6 mph	0 mph	29.14 in	0.0 in	Mostly Cloudy
7:14 PM	64 °F	58 °F	80 %	CALM	0 mph	0 mph	29.14 in	0.0 in	Mostly Cloudy
7:27 PM	64 °F	58 °F	80 %	E	3 mph	0 mph	29.14 in	0.0 in	Light Rain
7:51 PM	64 °F	58 °F	80 %	CALM	0 mph	0 mph	29.14 in	0.0 in	Mostly Cloudy
8:03 PM	64 °F	58 °F	80 %	E	3 mph	0 mph	29.14 in	0.0 in	Mostly Cloudy
8:51 PM	63 °F	59 °F	87 %	CALM	0 mph	0 mph	29.14 in	0.0 in	Mostly Cloudy
9:37 PM	62 °F	59 °F	90 %	N	5 mph	0 mph	29.15 in	0.0 in	Mostly Cloudy
9:51 PM	62 °F	59 °F	90 %	N	3 mph	0 mph	29.16 in	0.0 in	Mostly Cloudy
10:26 PM	61 °F	58 °F	90 %	NW	5 mph	0 mph	29.16 in	0.0 in	Mostly Cloudy
10:37 PM	61 °F	58 °F	90 %	W	6 mph	0 mph	29.16 in	0.0 in	Light Rain
10:48 PM	61 °F	59 °F	94 %	W	3 mph	0 mph	29.16 in	0.0 in	Light Rain
10:51 PM	61 °F	59 °F	93 %	CALM	0 mph	0 mph	29.16 in	0.0 in	Light Rain
11:51 PM	61 °F	58 °F	90 %	WNW	5 mph	0 mph	29.16 in	0.0 in	Light Rain

Wednesday November 15th, 2023

Time	Temperature	Dew Point	Humidity	Wind	Wind Speed	Wind Gust	Pressure	Precip.	Condition
12:51 AM	41 °F	29 °F	62 %	CALM	0 mph	0 mph	30.08 in	0.0 in	Cloudy
1:51 AM	40 °F	30 °F	68 %	NW	3 mph	0 mph	30.09 in	0.0 in	Cloudy
2:51 AM	36 °F	28 °F	73 %	CALM	0 mph	0 mph	30.09 in	0.0 in	Partly Cloudy
3:51 AM	33 °F	27 °F	78 %	CALM	0 mph	0 mph	30.09 in	0.0 in	Partly Cloudy
4:51 AM	30 °F	27 °F	88 %	CALM	0 mph	0 mph	30.09 in	0.0 in	Fair
5:51 AM	29 °F	26 °F	89 %	CALM	0 mph	0 mph	30.09 in	0.0 in	Fair
6:51 AM	29 °F	26 °F	89 %	CALM	0 mph	0 mph	30.11 in	0.0 in	Mostly Cloudy
7:51 AM	34 °F	30 °F	85 %	SSE	6 mph	0 mph	30.11 in	0.0 in	Mostly Cloudy
8:51 AM	38 °F	31 °F	76 %	SSE	6 mph	0 mph	30.12 in	0.0 in	Mostly Cloudy
9:51 AM	43 °F	32 °F	65 %	SSE	15 mph	22 mph	30.10 in	0.0 in	Mostly Cloudy
10:51 AM	45 °F	32 °F	60 %	S	10 mph	0 mph	30.07 in	0.0 in	Cloudy
11:51 AM	47 °F	32 °F	56 %	SSE	9 mph	0 mph	30.04 in	0.0 in	Mostly Cloudy
12:51 PM	48 °F	32 °F	54 %	SSE	9 mph	0 mph	30.00 in	0.0 in	Mostly Cloudy
1:51 PM	49 °F	32 °F	52 %	SSE	10 mph	0 mph	29.97 in	0.0 in	Mostly Cloudy
2:51 PM	51 °F	32 °F	48 %	SSE	10 mph	0 mph	29.94 in	0.0 in	Mostly Cloudy
3:51 PM	50 °F	32 °F	50 %	S	12 mph	0 mph	29.92 in	0.0 in	Mostly Cloudy
4:51 PM	50 °F	32 °F	50 %	S	10 mph	0 mph	29.91 in	0.0 in	Mostly Cloudy
5:51 PM	48 °F	32 °F	54 %	SSE	10 mph	0 mph	29.90 in	0.0 in	Mostly Cloudy
6:51 PM	47 °F	32 °F	56 %	S	7 mph	0 mph	29.89 in	0.0 in	Mostly Cloudy
7:51 PM	47 °F	32 °F	56 %	SSE	9 mph	0 mph	29.89 in	0.0 in	Mostly Cloudy
8:51 PM	47 °F	32 °F	56 %	SSE	8 mph	0 mph	29.89 in	0.0 in	Mostly Cloudy
9:51 PM	45 °F	32 °F	60 %	SSE	8 mph	0 mph	29.90 in	0.0 in	Fair
10:51 PM	41 °F	31 °F	67 %	CALM	0 mph	0 mph	29.90 in	0.0 in	Fair
11:51 PM	39 °F	30 °F	70 %	S	3 mph	0 mph	29.90 in	0.0 in	Fair

Thursday November 16th, 2023

Time	Temperature	Dew Point	Humidity	Wind	Wind Speed	Wind Gust	Pressure	Precip.	Condition
12:51 AM	38 °F	30 °F	73 %	CALM	0 mph	0 mph	29.89 in	0.0 in	Fair
1:51 AM	37 °F	30 °F	76 %	CALM	0 mph	0 mph	29.88 in	0.0 in	Fair
2:51 AM	32 °F	27 °F	82 %	CALM	0 mph	0 mph	29.88 in	0.0 in	Fair
3:51 AM	35 °F	29 °F	78 %	CALM	0 mph	0 mph	29.91 in	0.0 in	Fair
4:51 AM	34 °F	29 °F	82 %	VAR	6 mph	0 mph	29.92 in	0.0 in	Fair
5:51 AM	34 °F	29 °F	82 %	S	3 mph	0 mph	29.92 in	0.0 in	Fair
6:51 AM	34 °F	29 °F	82 %	CALM	0 mph	0 mph	29.93 in	0.0 in	Fair
7:51 AM	35 °F	31 °F	85 %	S	3 mph	0 mph	29.94 in	0.0 in	Fair
8:51 AM	43 °F	34 °F	71 %	S	5 mph	0 mph	29.95 in	0.0 in	Fair
9:51 AM	48 °F	34 °F	58 %	S	6 mph	0 mph	29.96 in	0.0 in	Fair
10:51 AM	52 °F	35 °F	53 %	S	5 mph	0 mph	29.94 in	0.0 in	Fair
11:51 AM	57 °F	35 °F	44 %	VAR	3 mph	0 mph	29.92 in	0.0 in	Fair
12:51 PM	58 °F	35 °F	42 %	E	3 mph	0 mph	29.89 in	0.0 in	Partly Cloudy
1:51 PM	60 °F	35 °F	39 %	CALM	0 mph	0 mph	29.87 in	0.0 in	Fair
2:51 PM	59 °F	35 °F	41 %	SE	6 mph	0 mph	29.87 in	0.0 in	Fair
3:51 PM	59 °F	34 °F	39 %	CALM	0 mph	0 mph	29.86 in	0.0 in	Mostly Cloudy
4:51 PM	51 °F	35 °F	54 %	CALM	0 mph	0 mph	29.86 in	0.0 in	Mostly Cloudy
5:51 PM	45 °F	34 °F	65 %	CALM	0 mph	0 mph	29.86 in	0.0 in	Mostly Cloudy
6:51 PM	43 °F	34 °F	71 %	CALM	0 mph	0 mph	29.85 in	0.0 in	Partly Cloudy
7:51 PM	41 °F	33 °F	73 %	CALM	0 mph	0 mph	29.85 in	0.0 in	Fair
8:51 PM	40 °F	33 °F	77 %	CALM	0 mph	0 mph	29.84 in	0.0 in	Fair
9:51 PM	38 °F	32 °F	79 %	CALM	0 mph	0 mph	29.84 in	0.0 in	Fair
10:51 PM	37 °F	32 °F	82 %	CALM	0 mph	0 mph	29.82 in	0.0 in	Fair
11:51 PM	36 °F	31 °F	82 %	CALM	0 mph	0 mph	29.82 in	0.0 in	Fair

TEST DATA - PRE-CONSTRUCTION SURVEY

Broadband Measurements (1Hz - 400kHz)

Complete data can be found here: [x SMP Data.xlsx](#)

Measurement Location 1

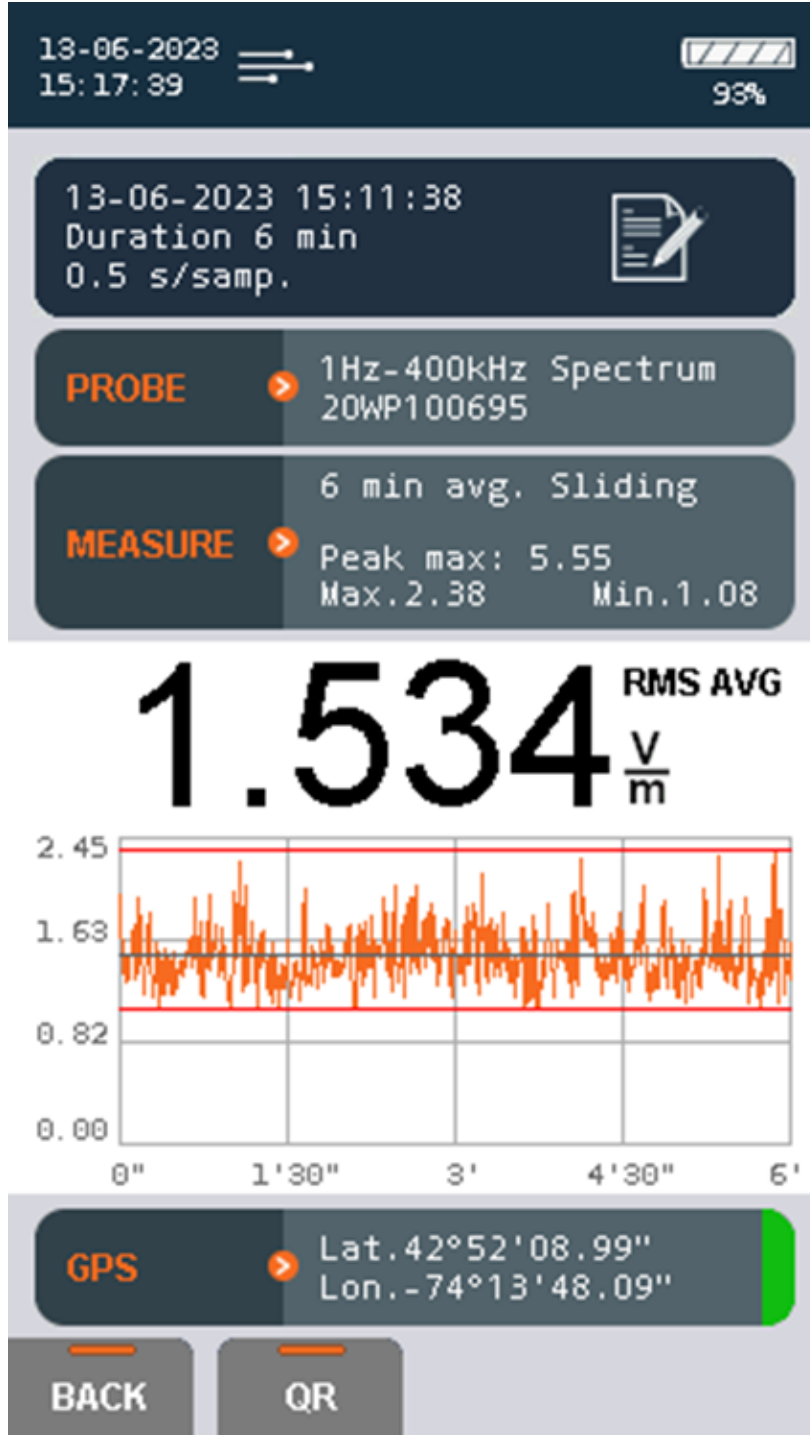

Measurement Location 2

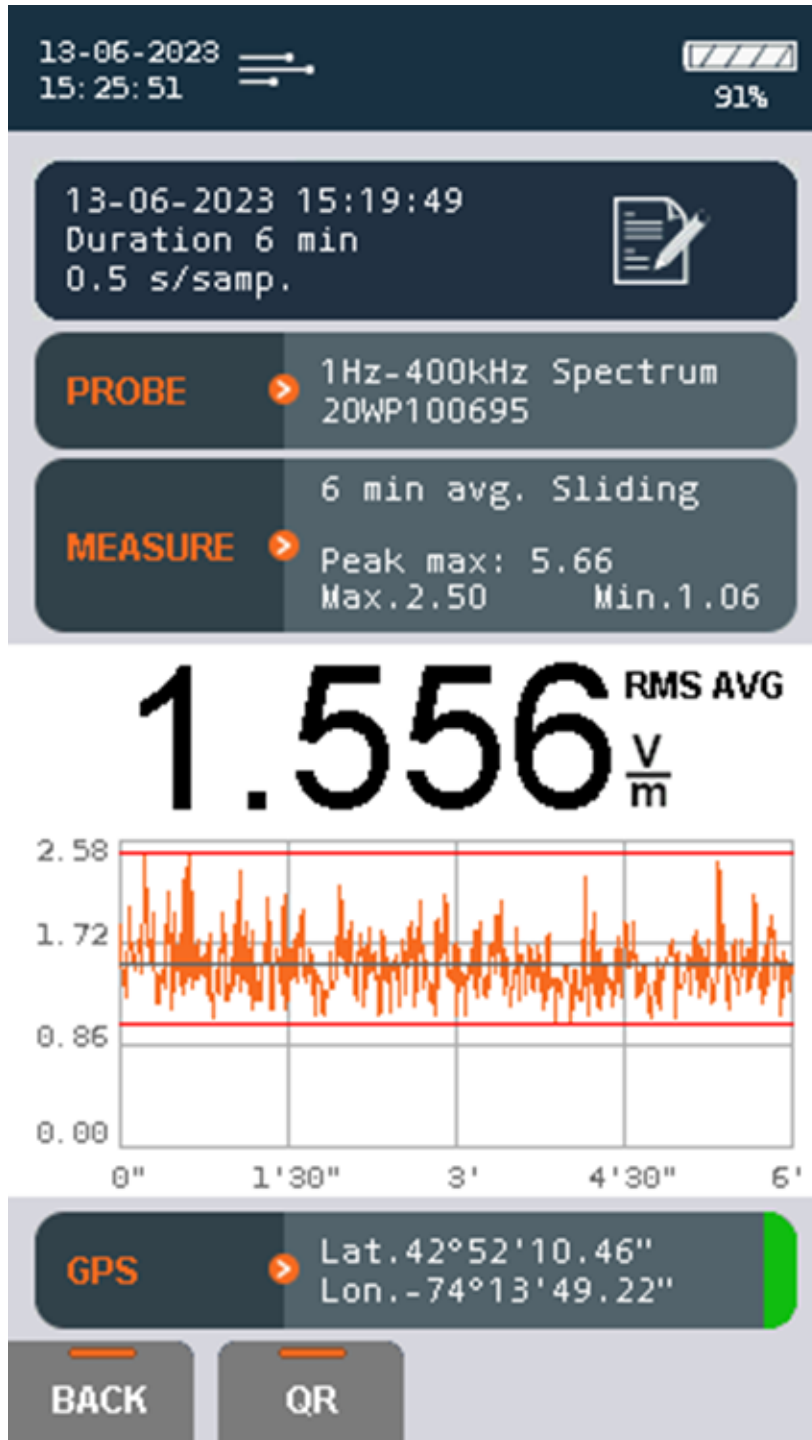

Measurement Location 3

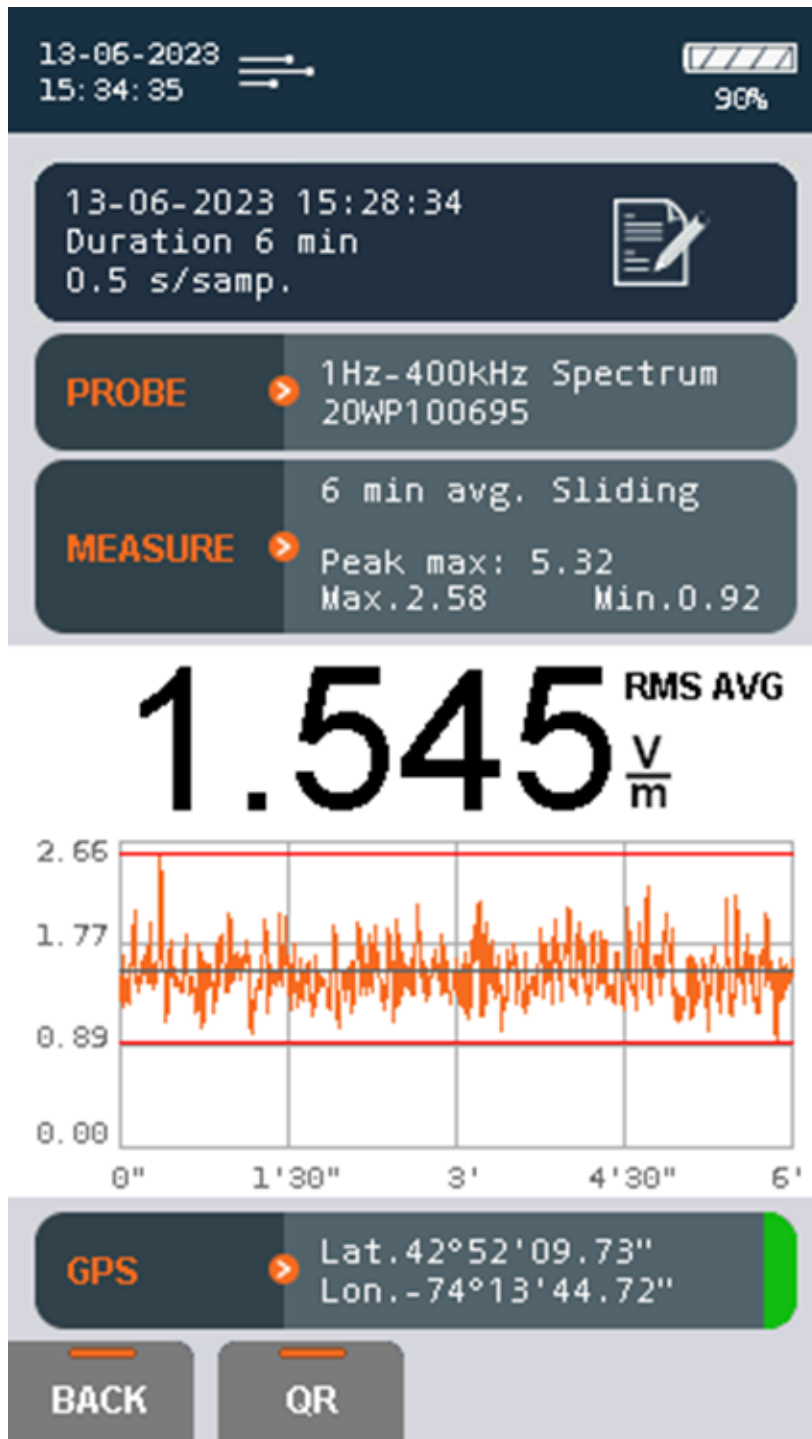

Measurement Location 4

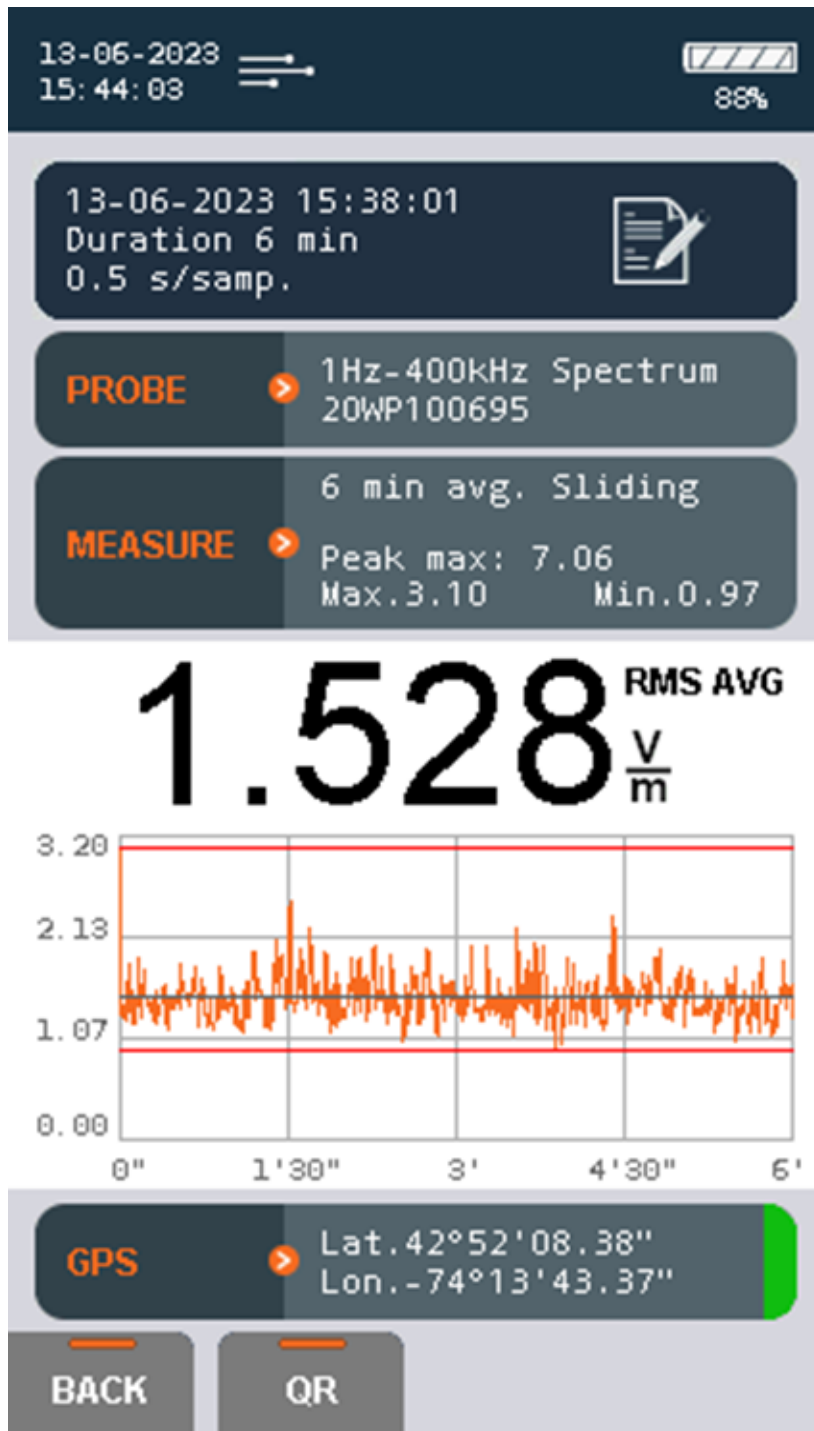

Measurement Location 5

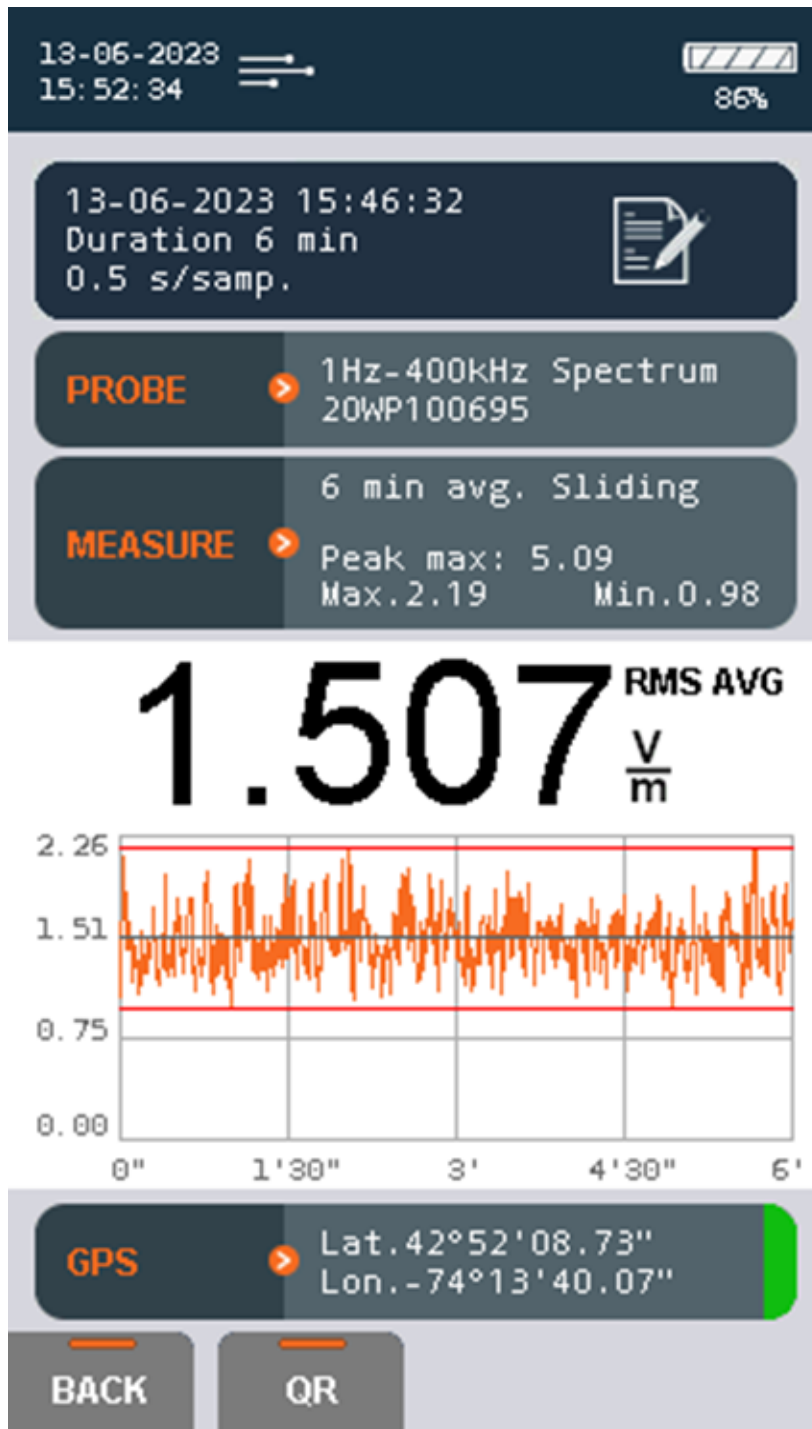

Measurement Location 6

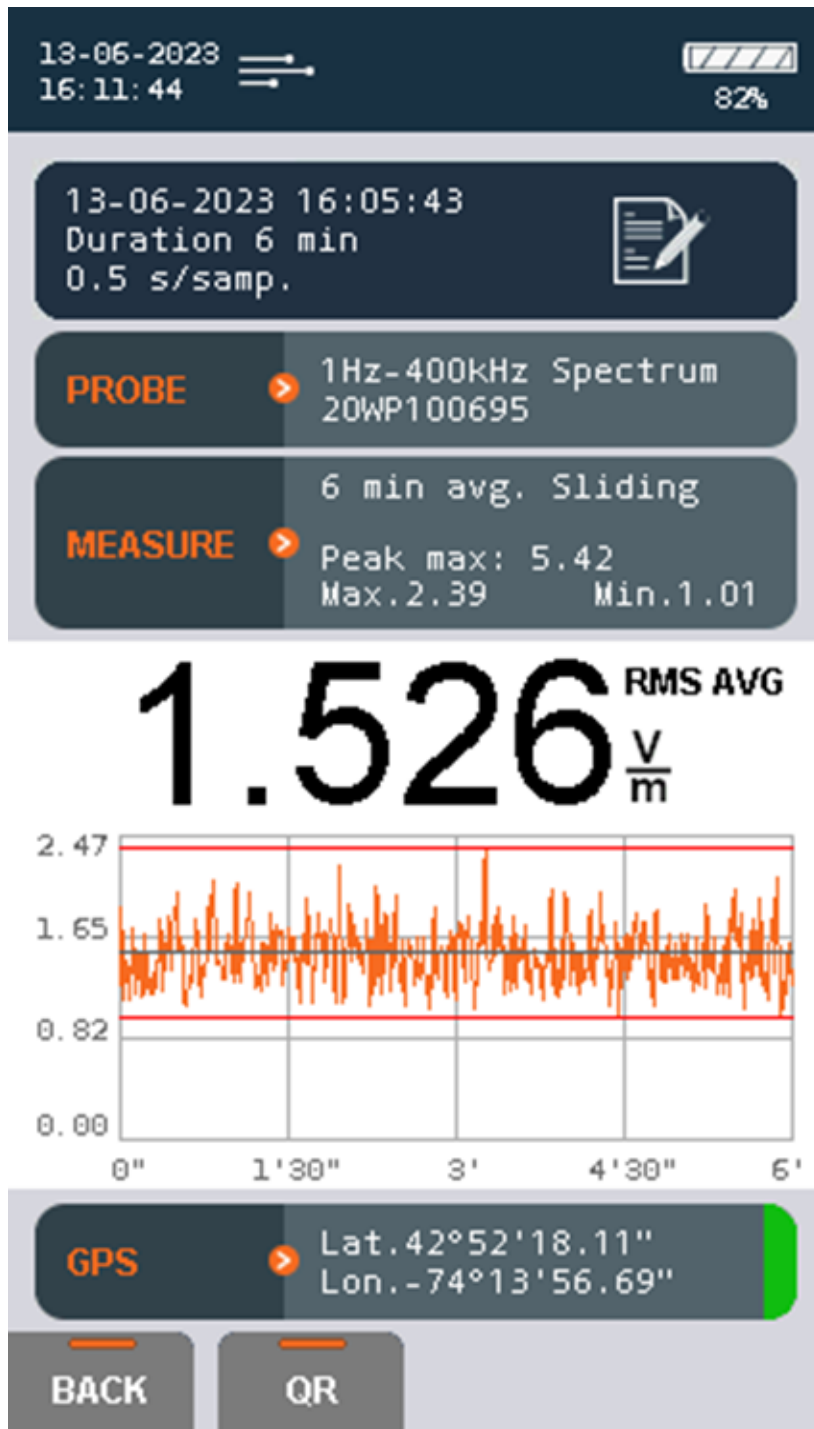

Measurement Location 7

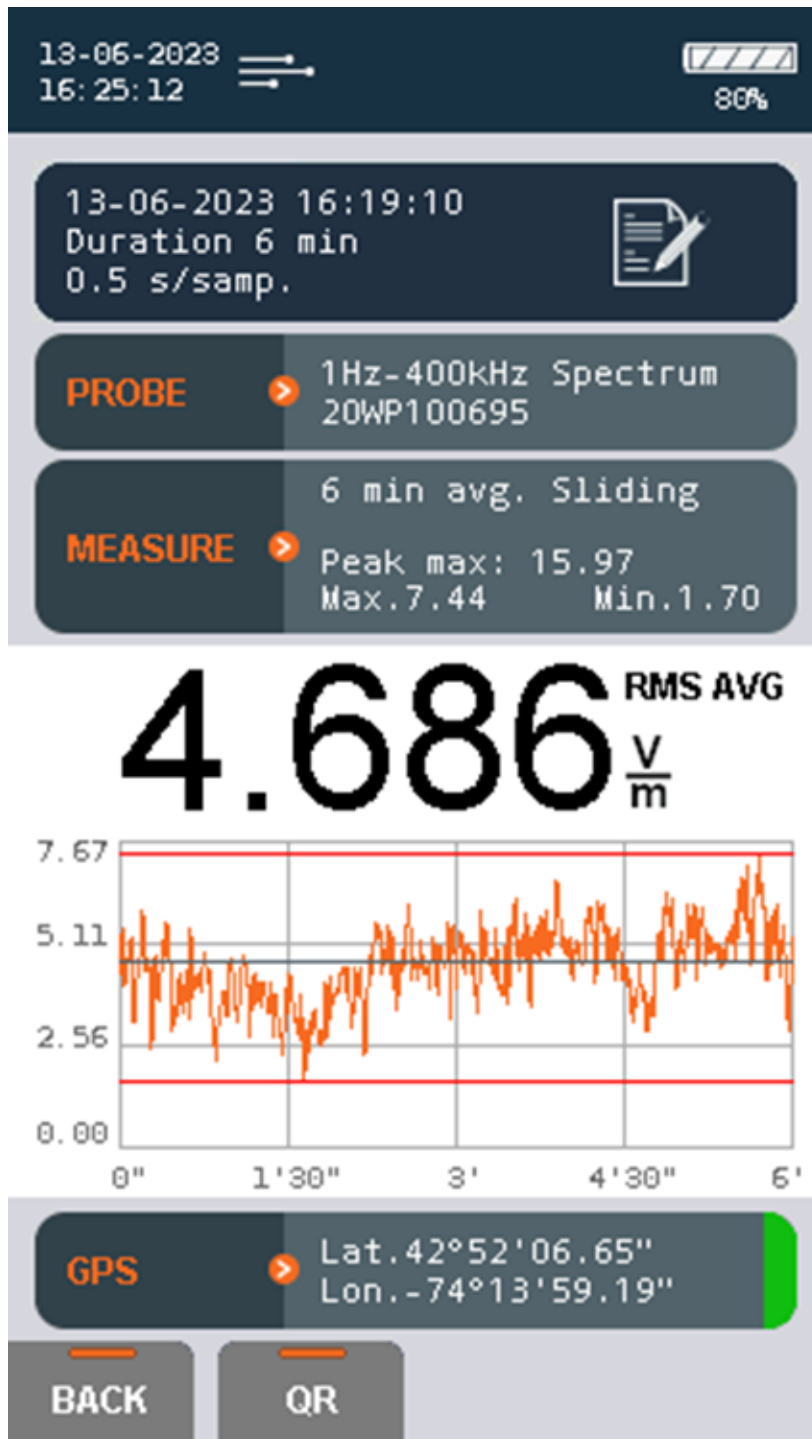

Measurement Location 8

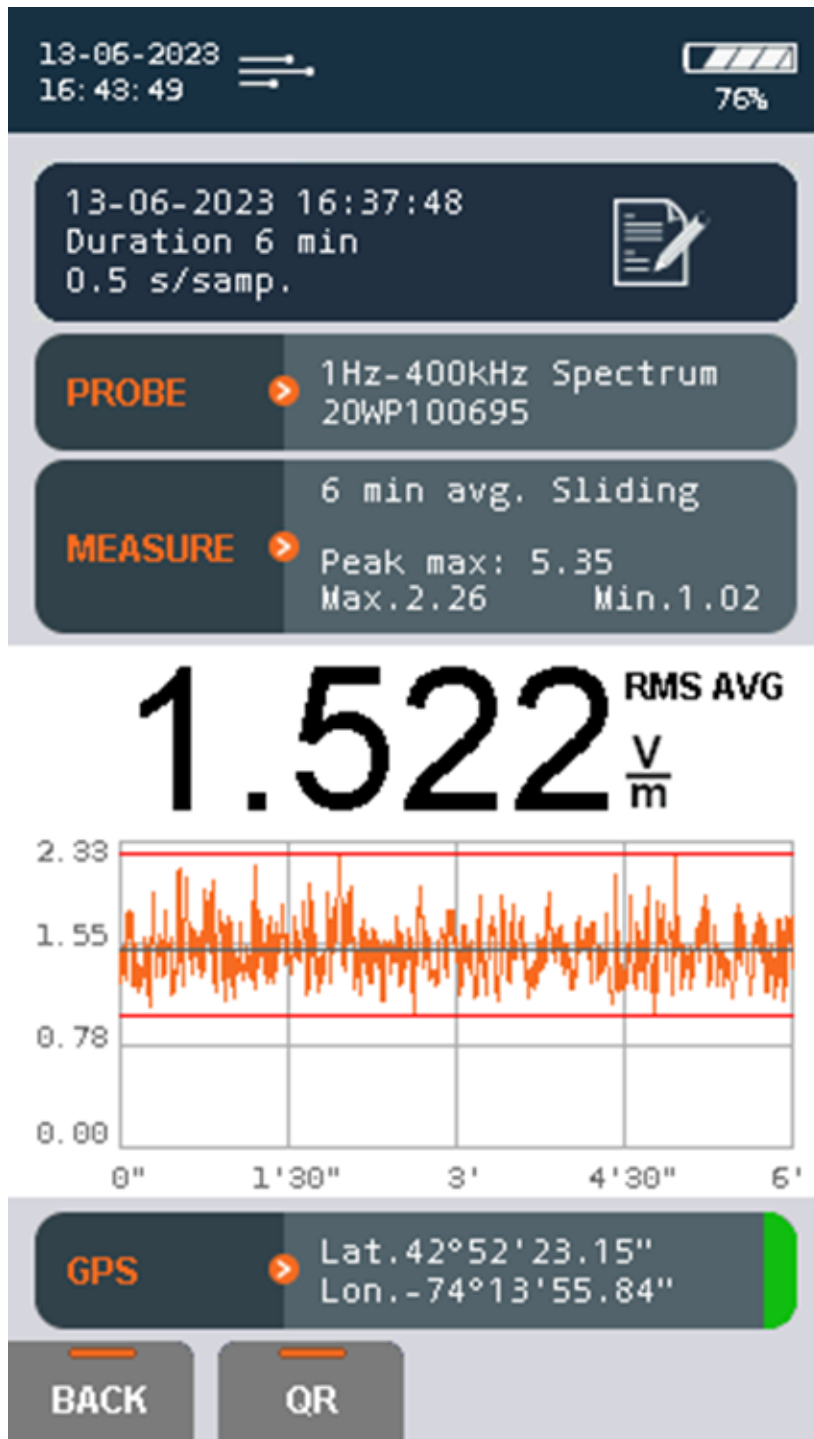

Measurement Location 9

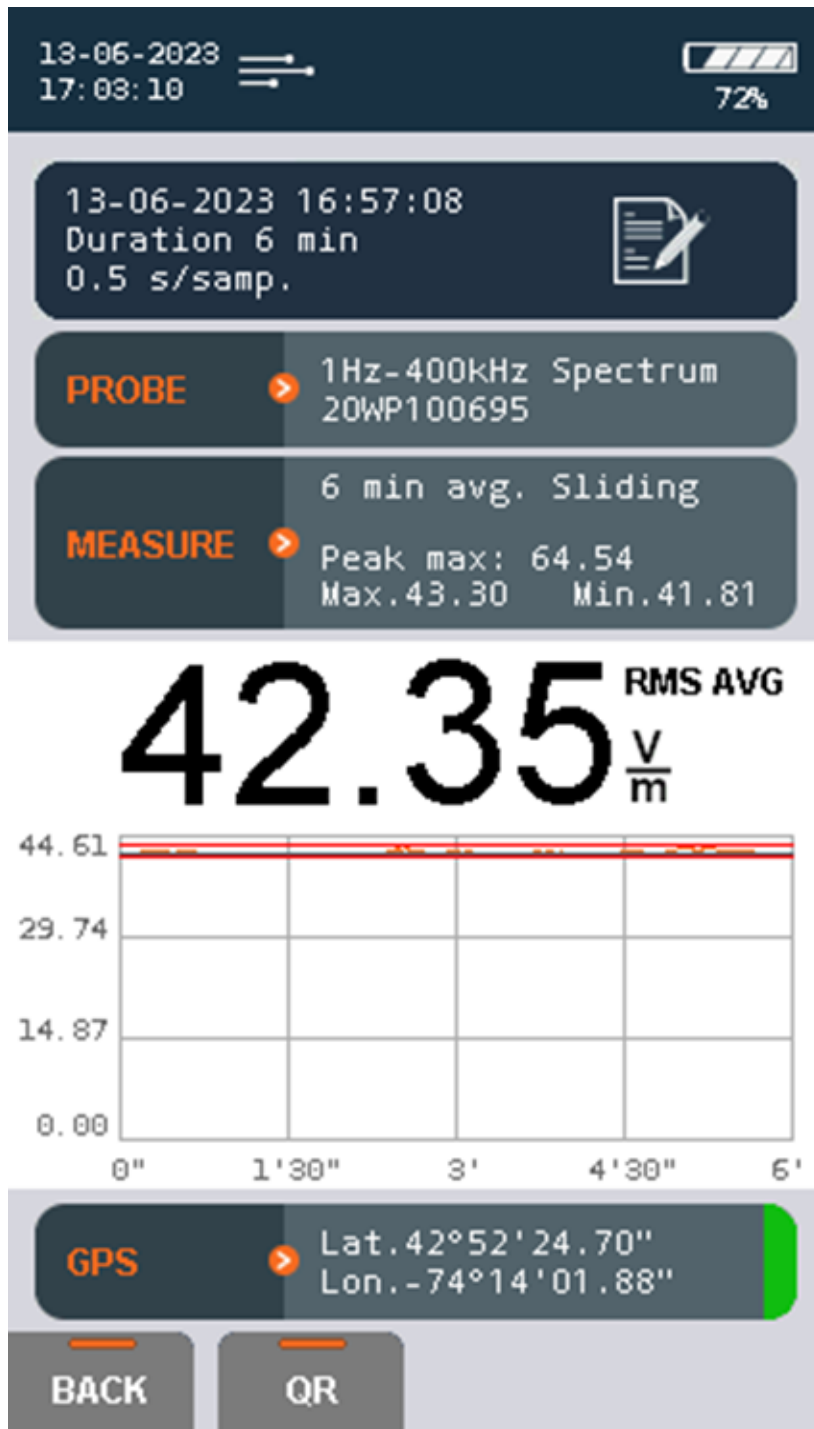

Measurement Location 10

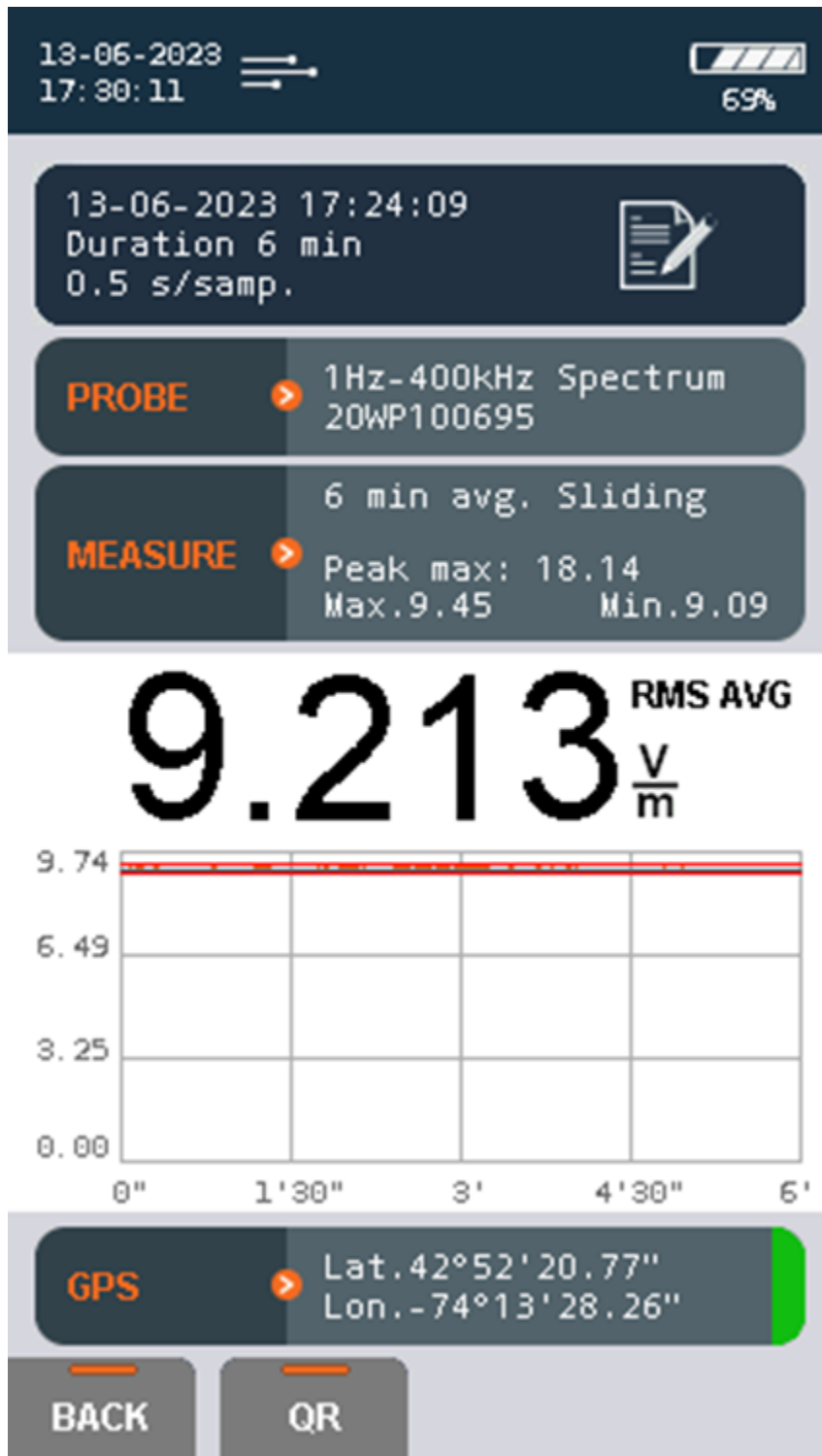

Measurement Location 11

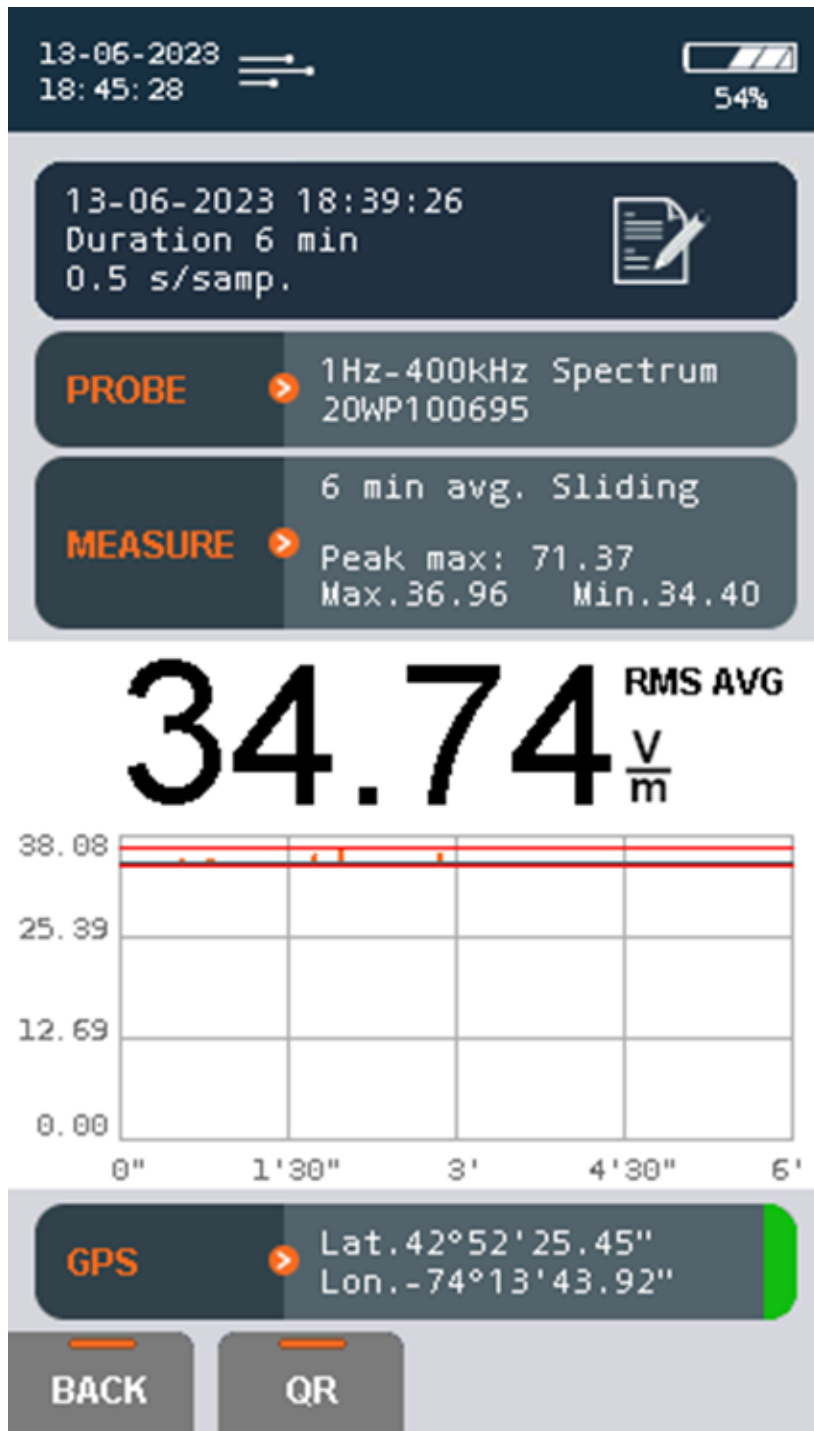

Measurement Location 12

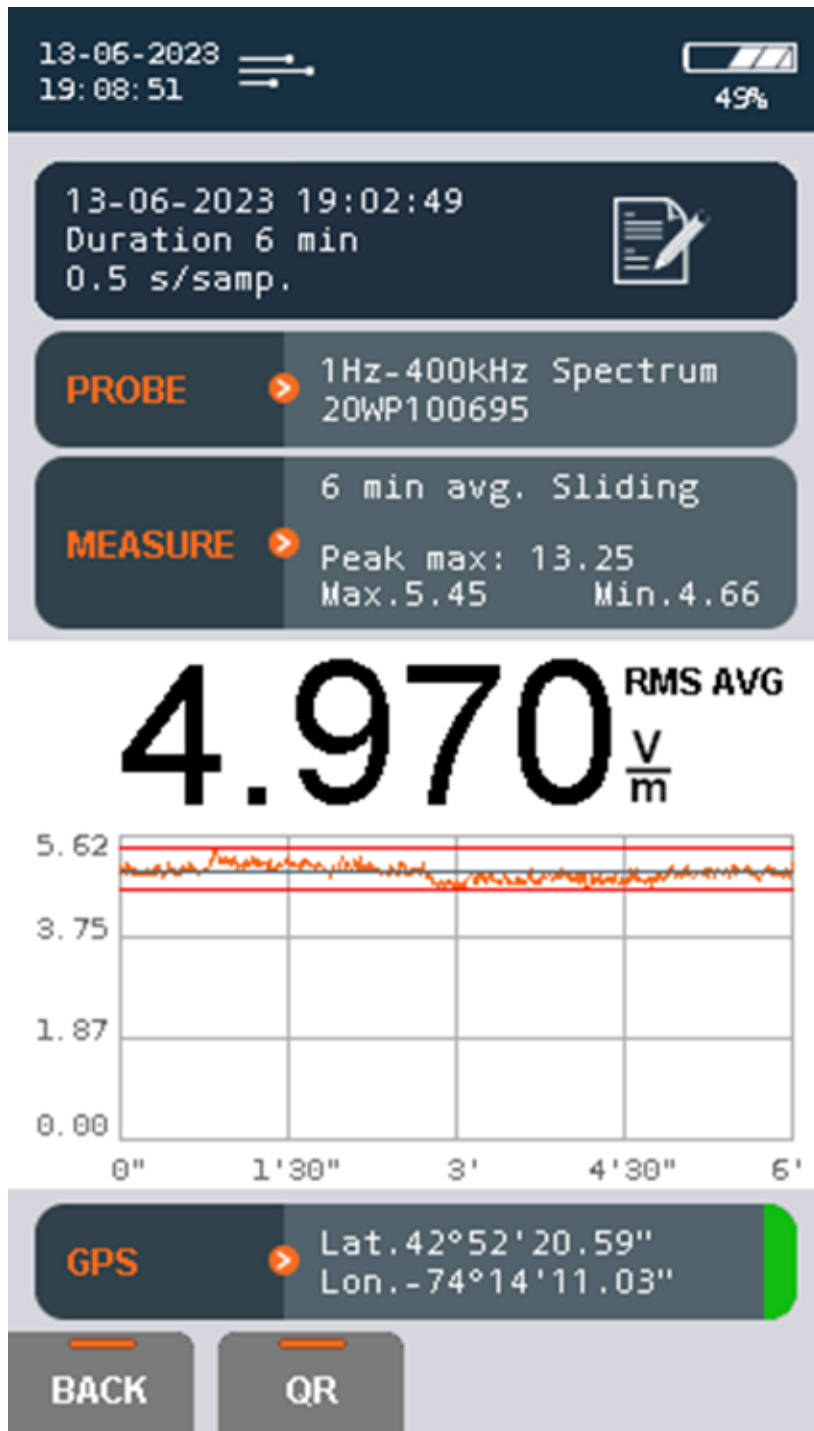

Measurement Location 13

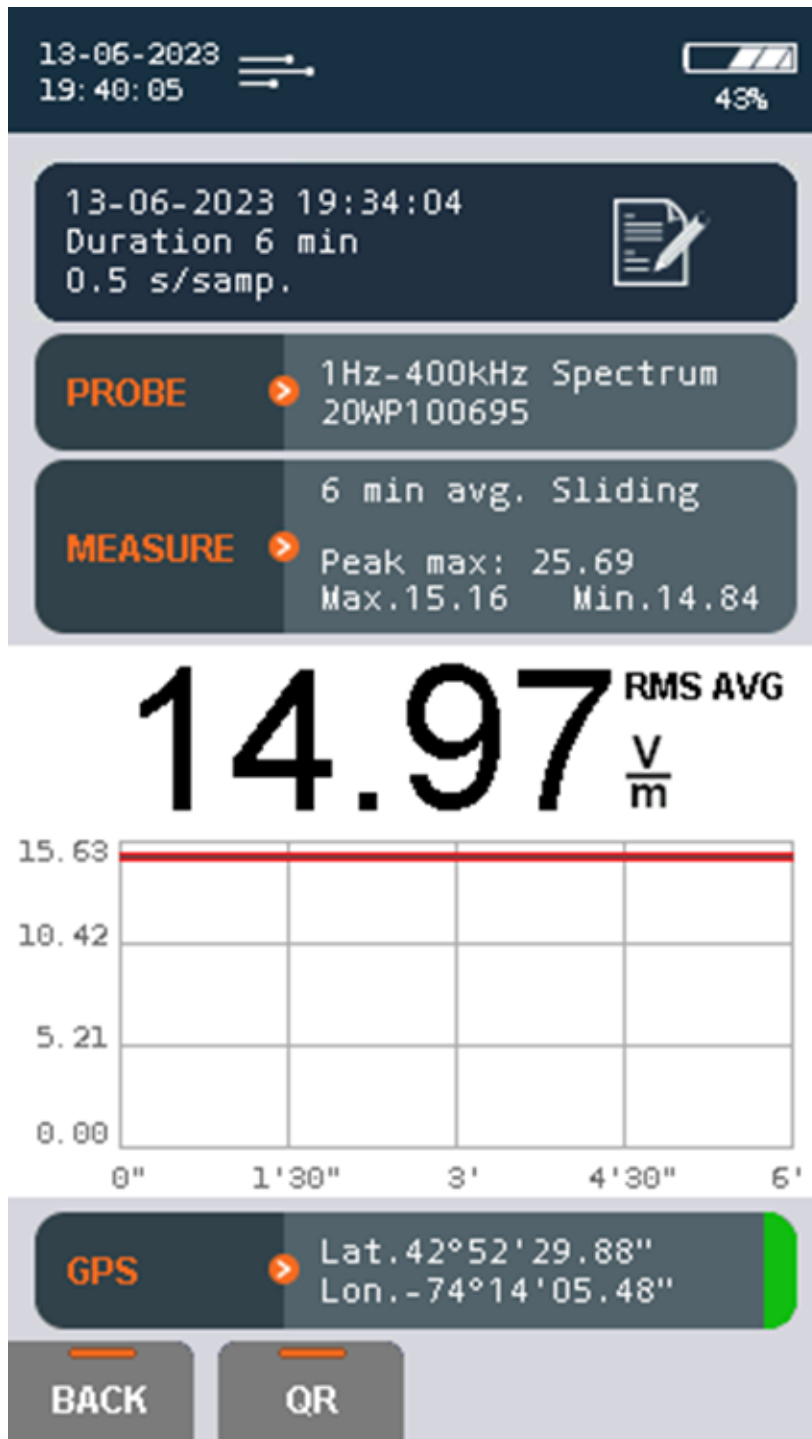

Broadband Measurements (300kHz-50GHz)

Measurement Paths/Locations	Signal Strength (V/m)
1 → 2	1.62
1 → 3	3.25
3 → 4	3.13
4 → 5	3.78
5 → 6	3.47
6 → 7	3.78
7 → 8	2.13
9	3.83
10	2.13
11	3.93
12	3.68
13	5.49
YMCA Road	2.75
Bean Hill Road	3.53

Narrowband Measurements

All data can be found here:

<https://drive.google.com/drive/folders/1Ugj-dKL4sQ-eILzOU1PDFtGPDSEsrhg?usp=sharing>

Measurement Location 1

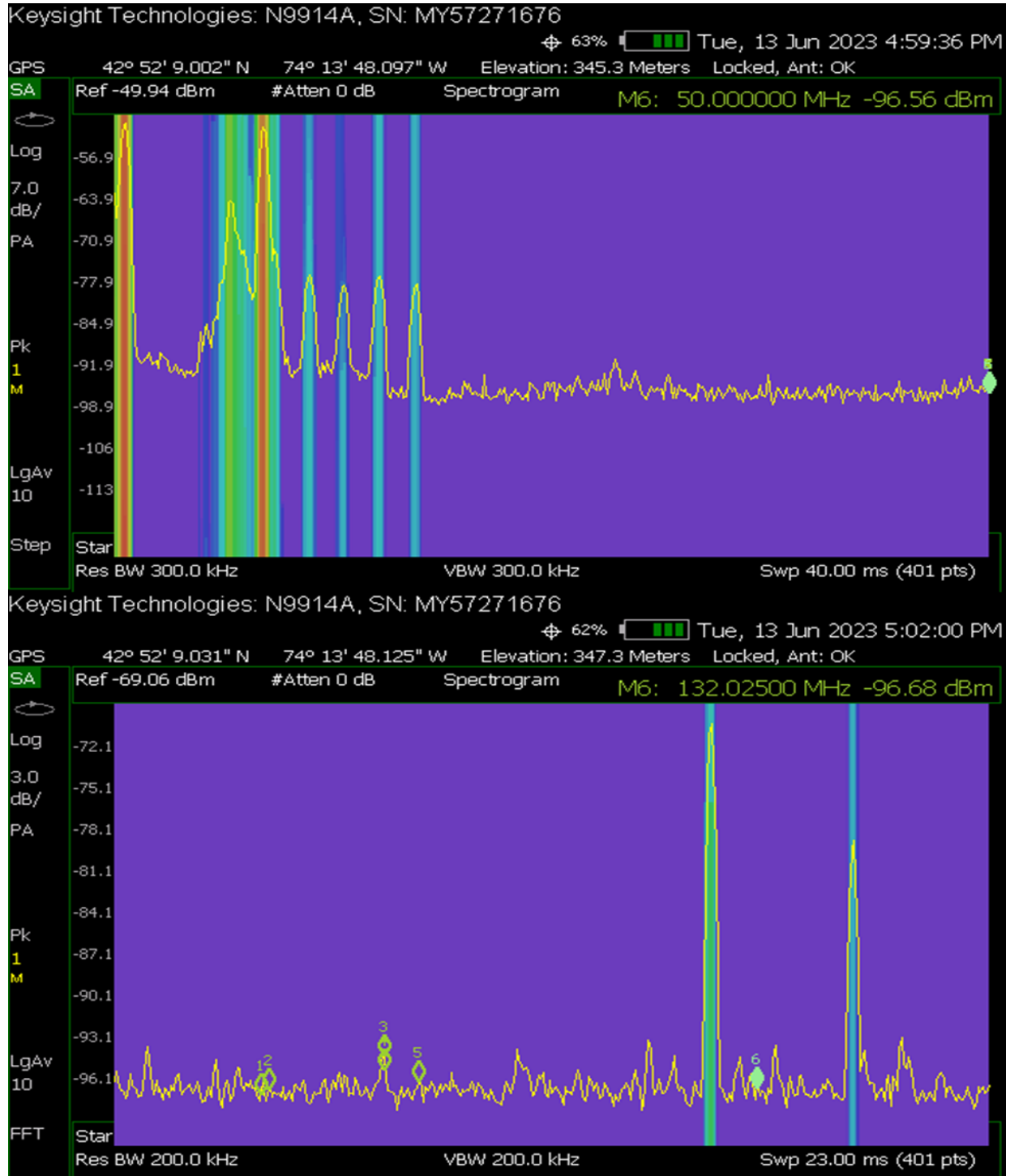

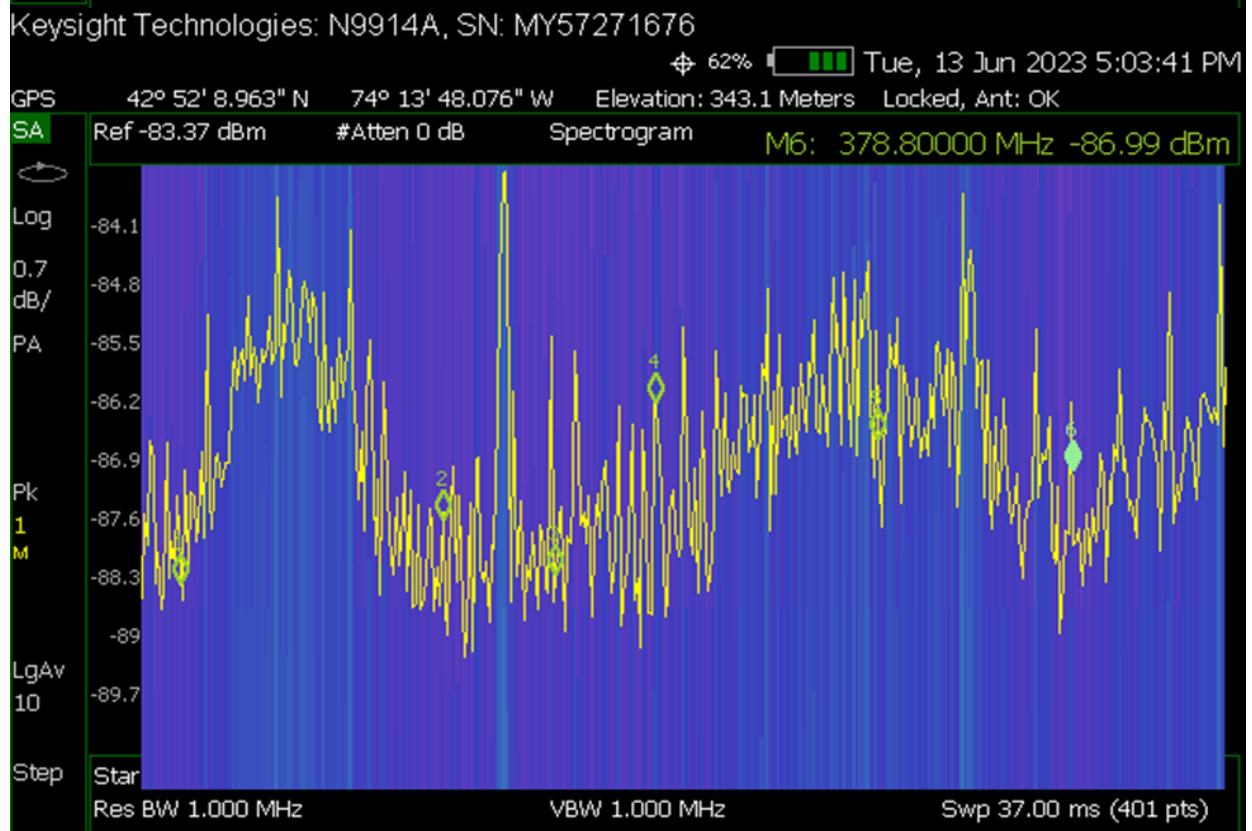
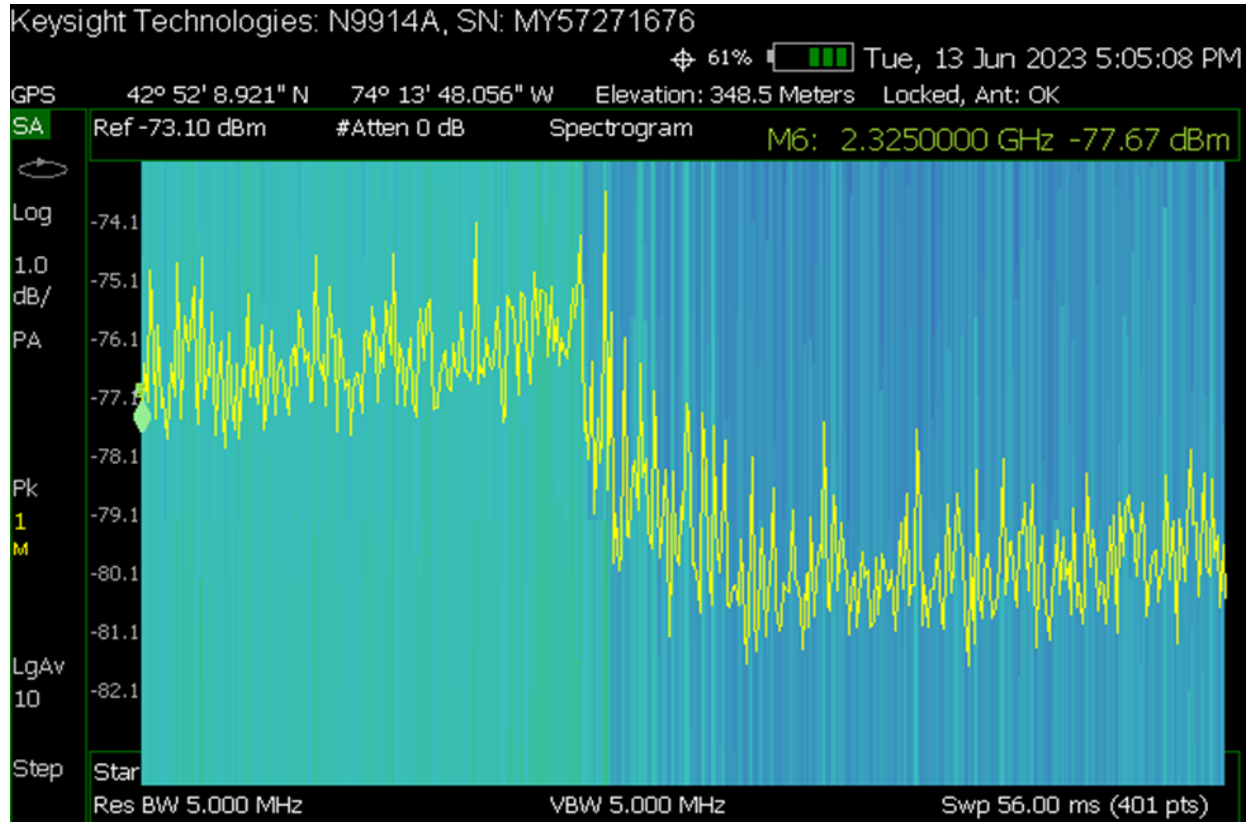

Measurement Location 2

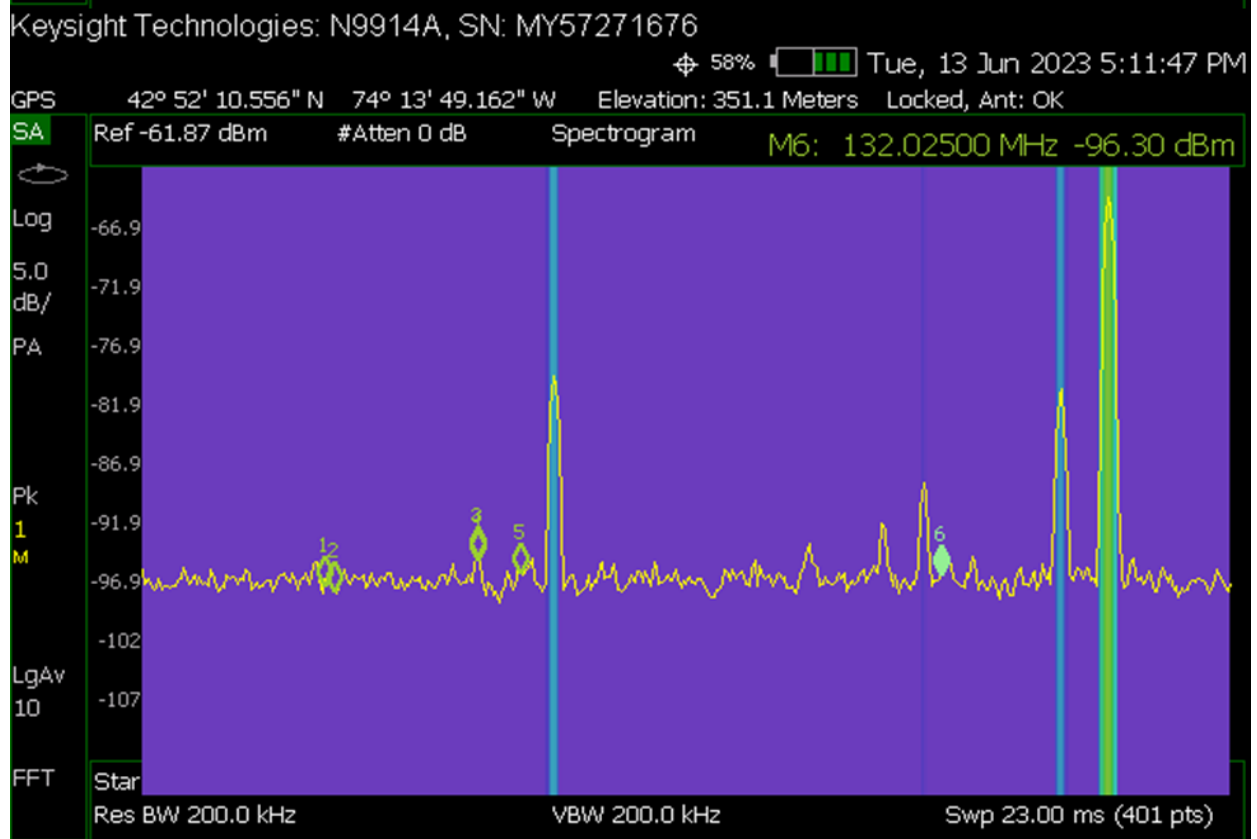
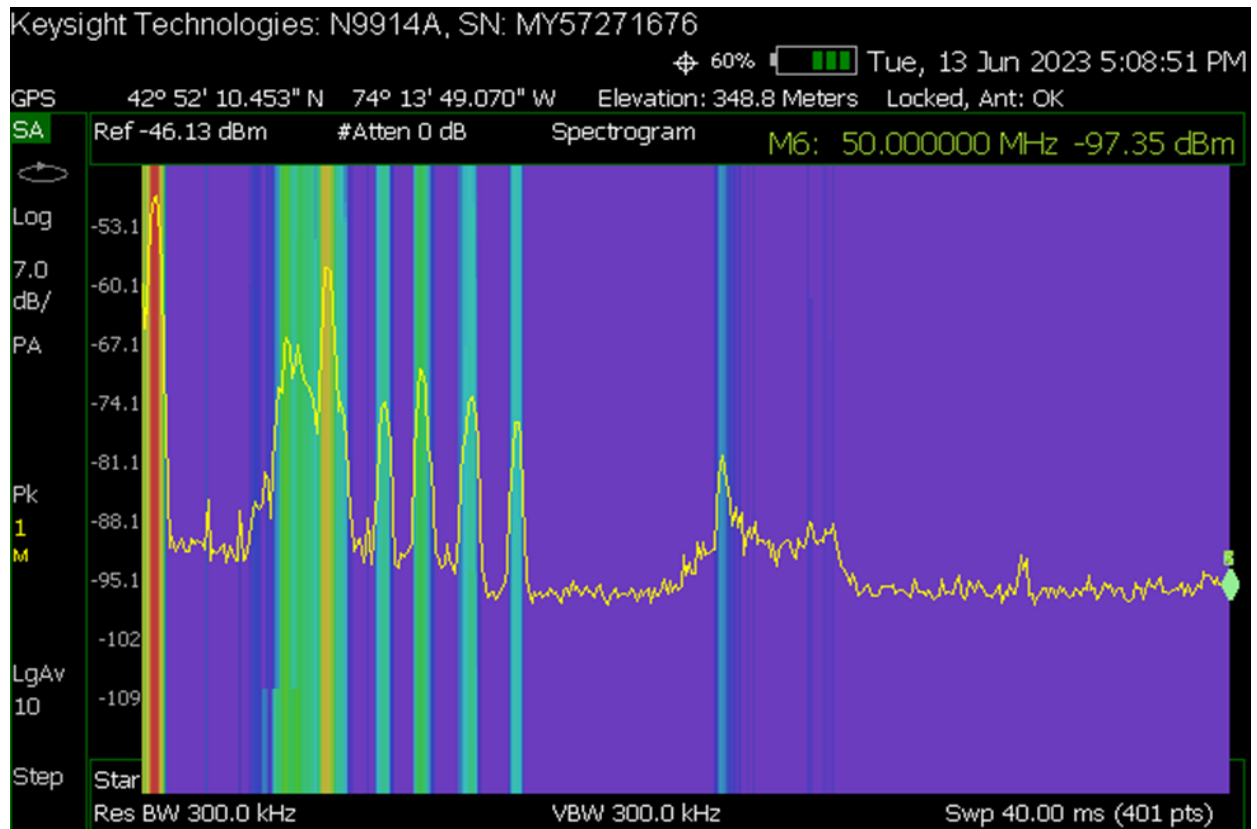

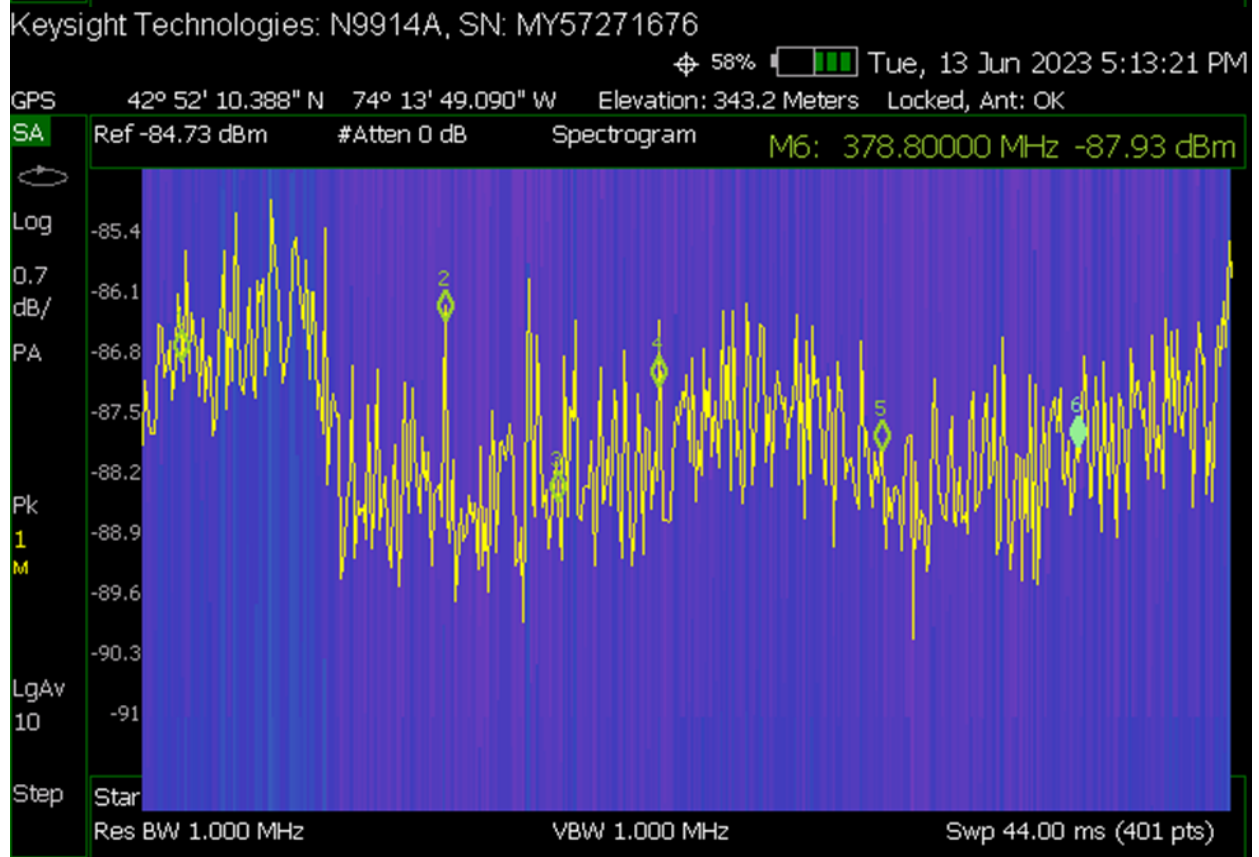
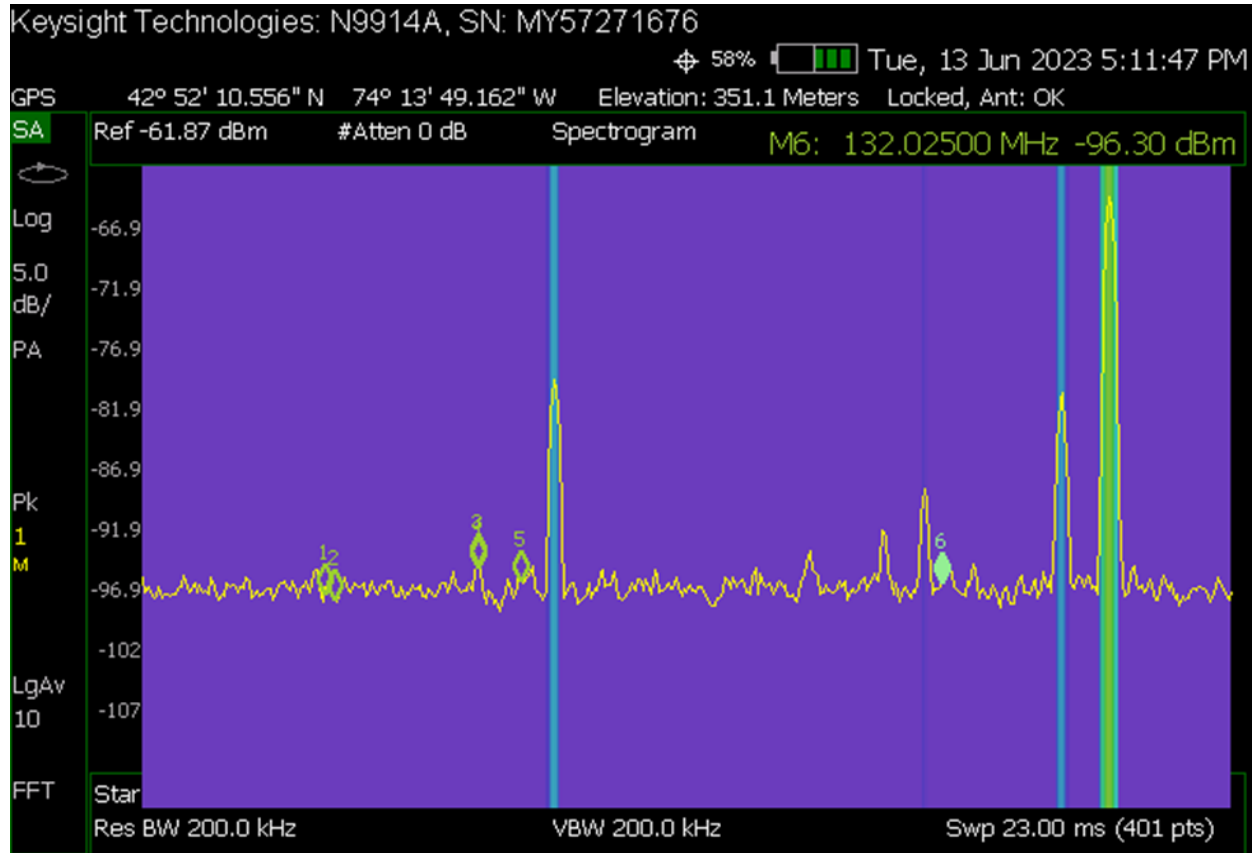

Measurement Location 3

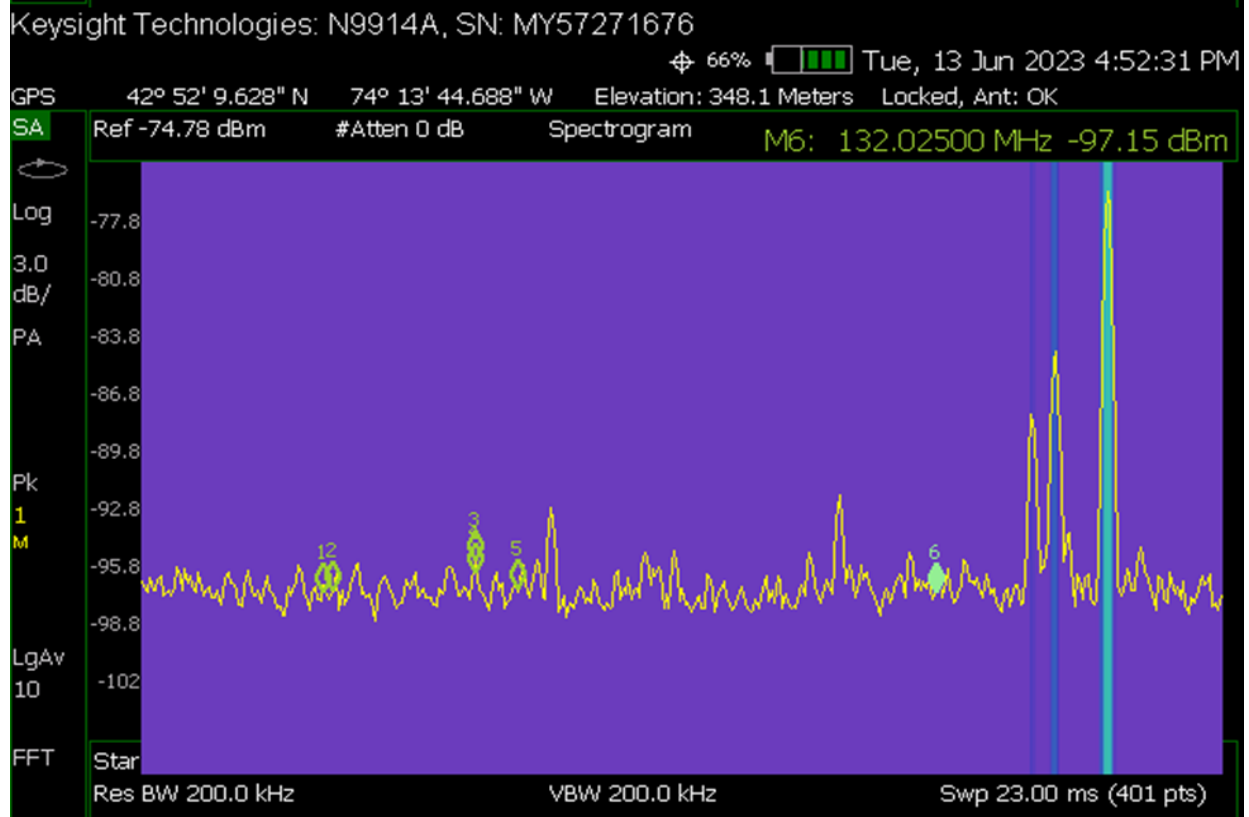
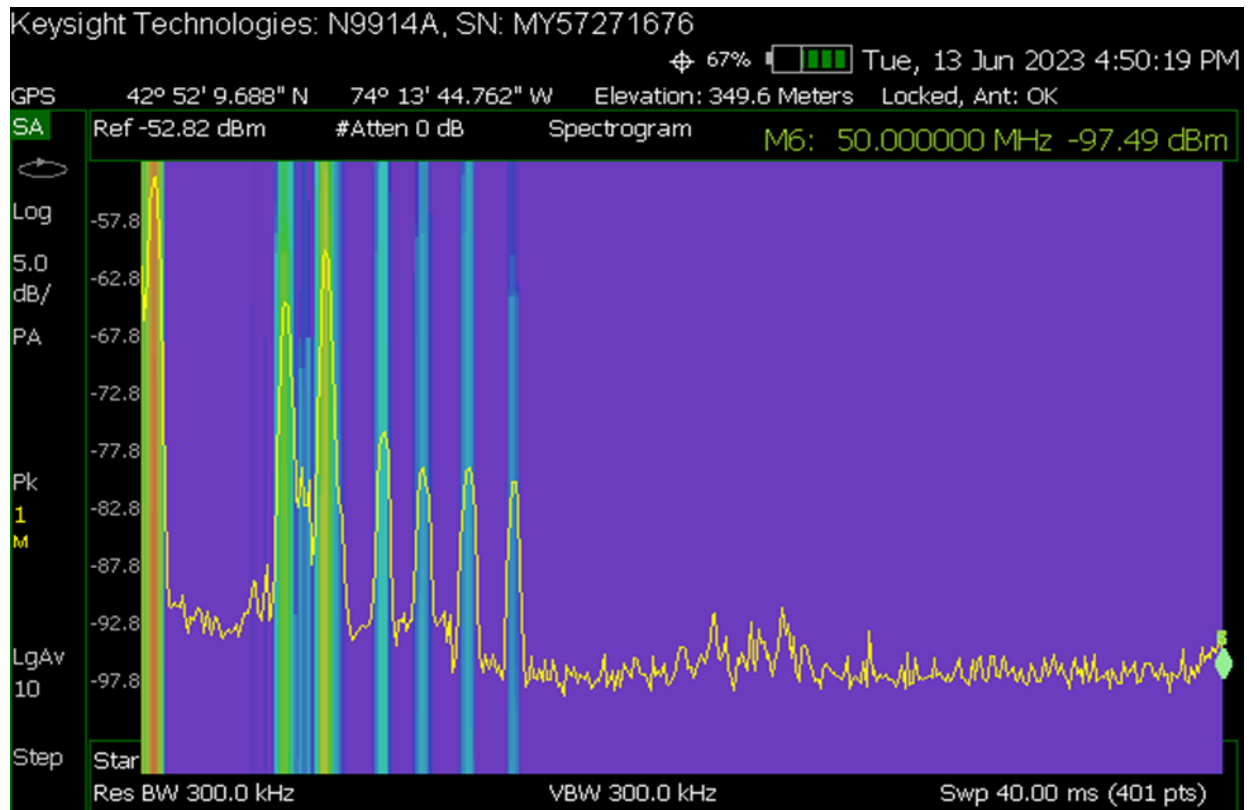

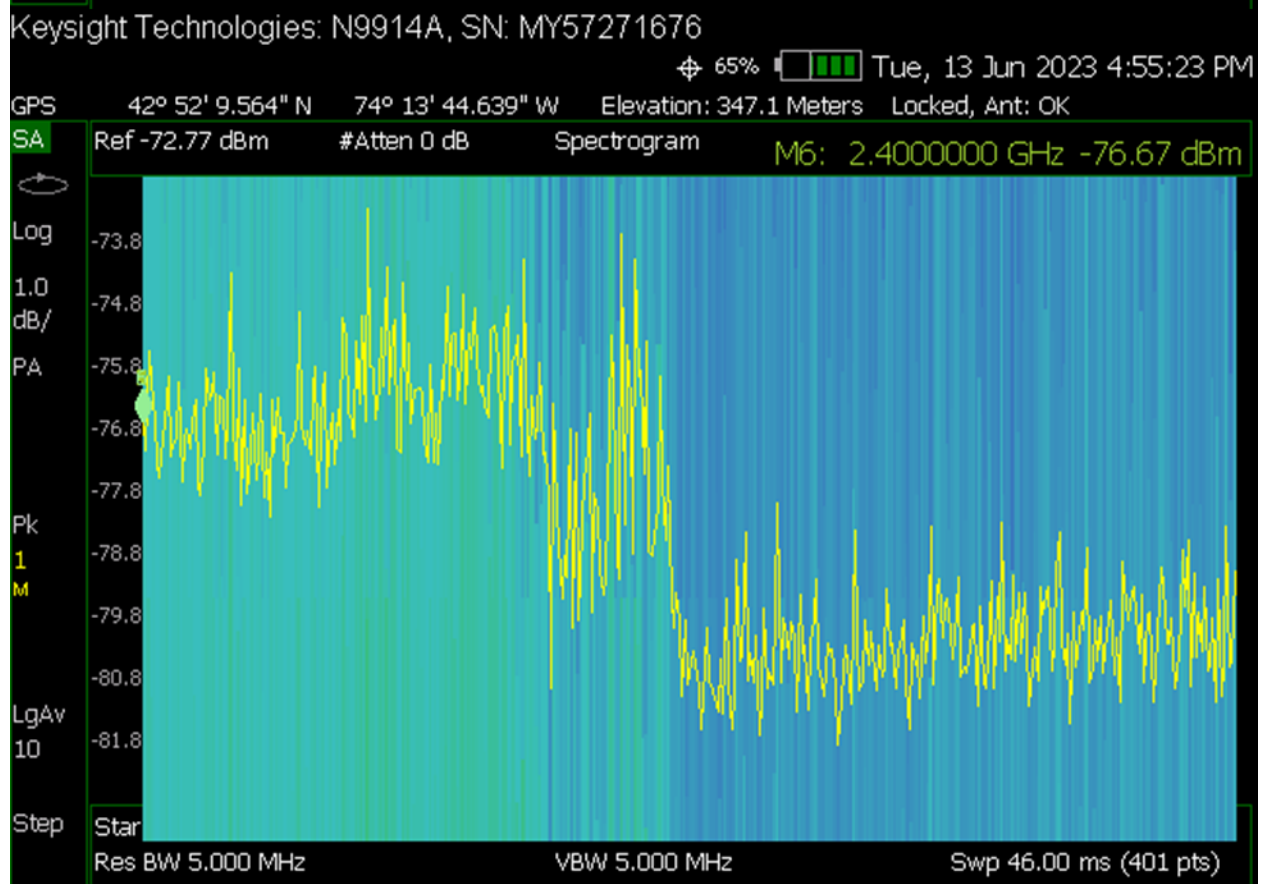
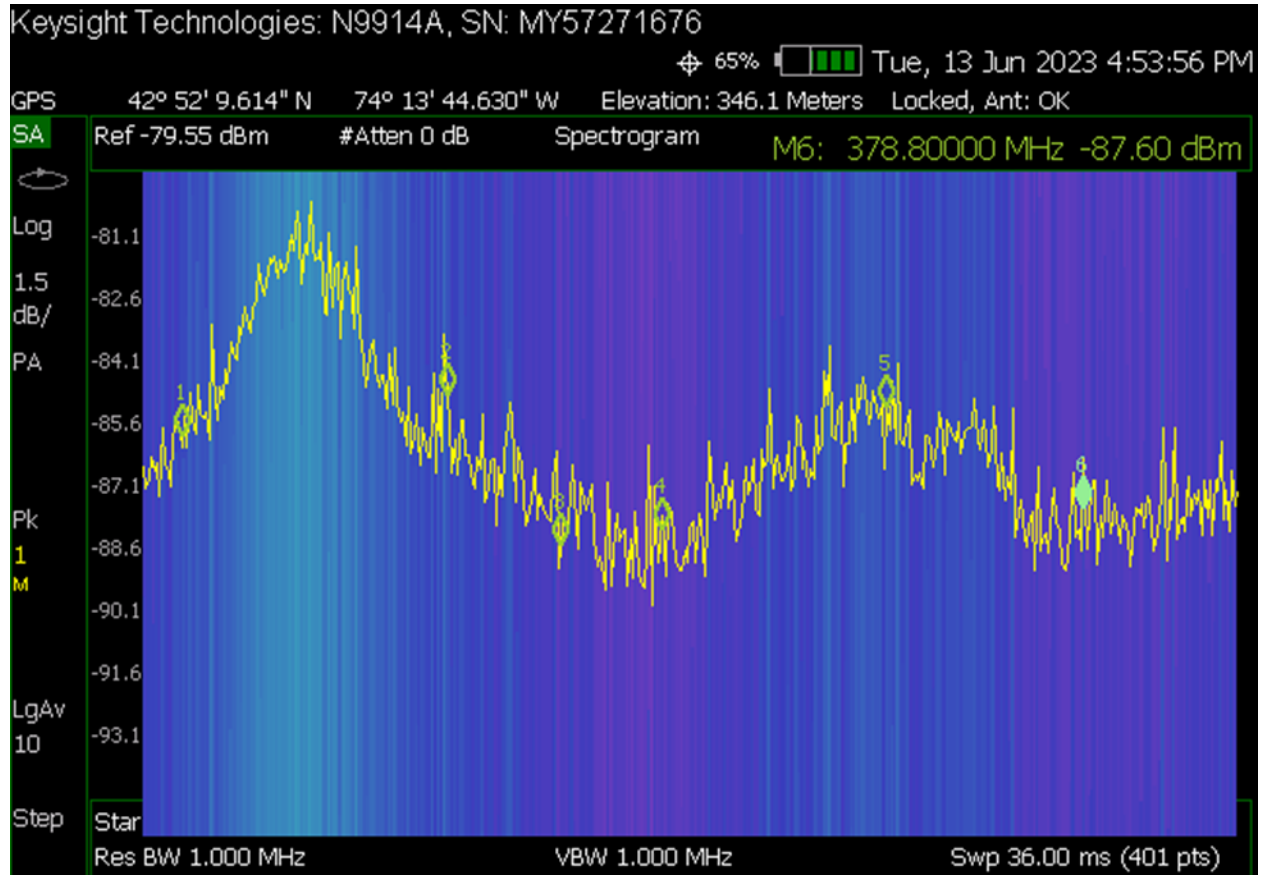

Measurement Location 4

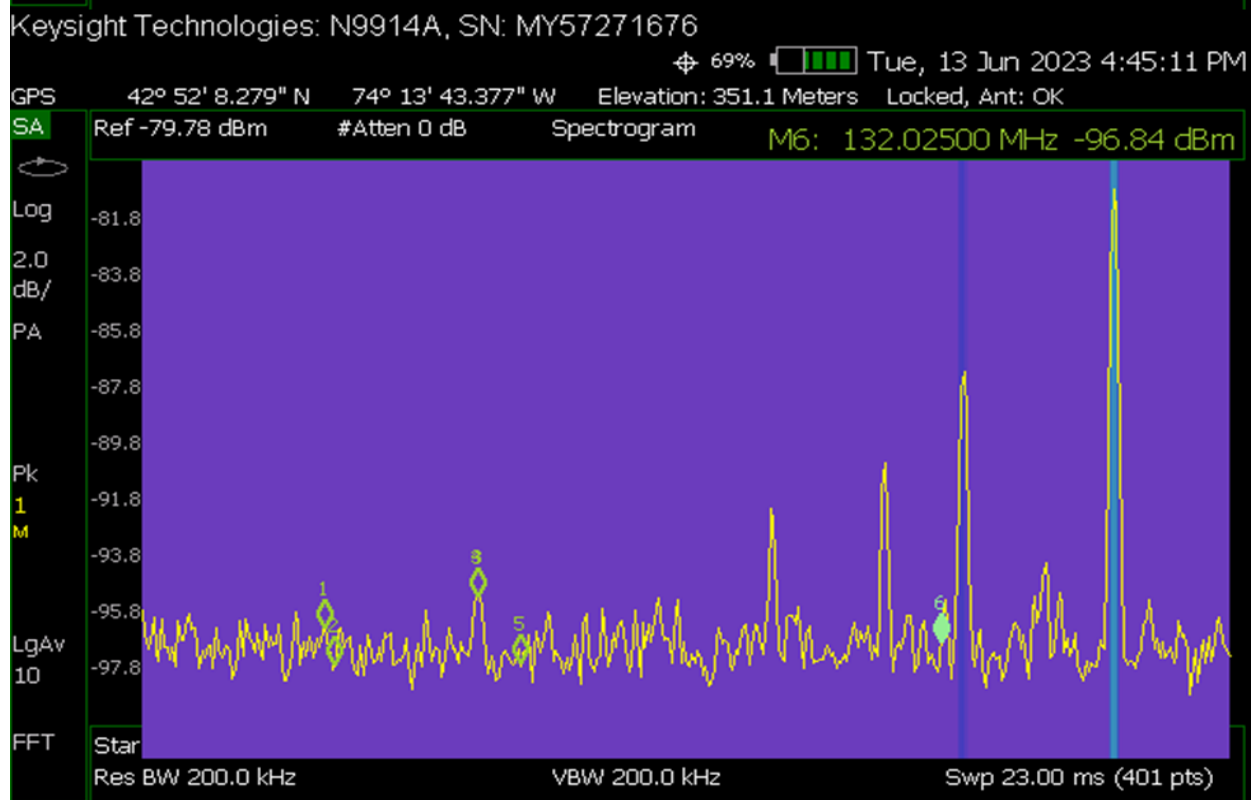
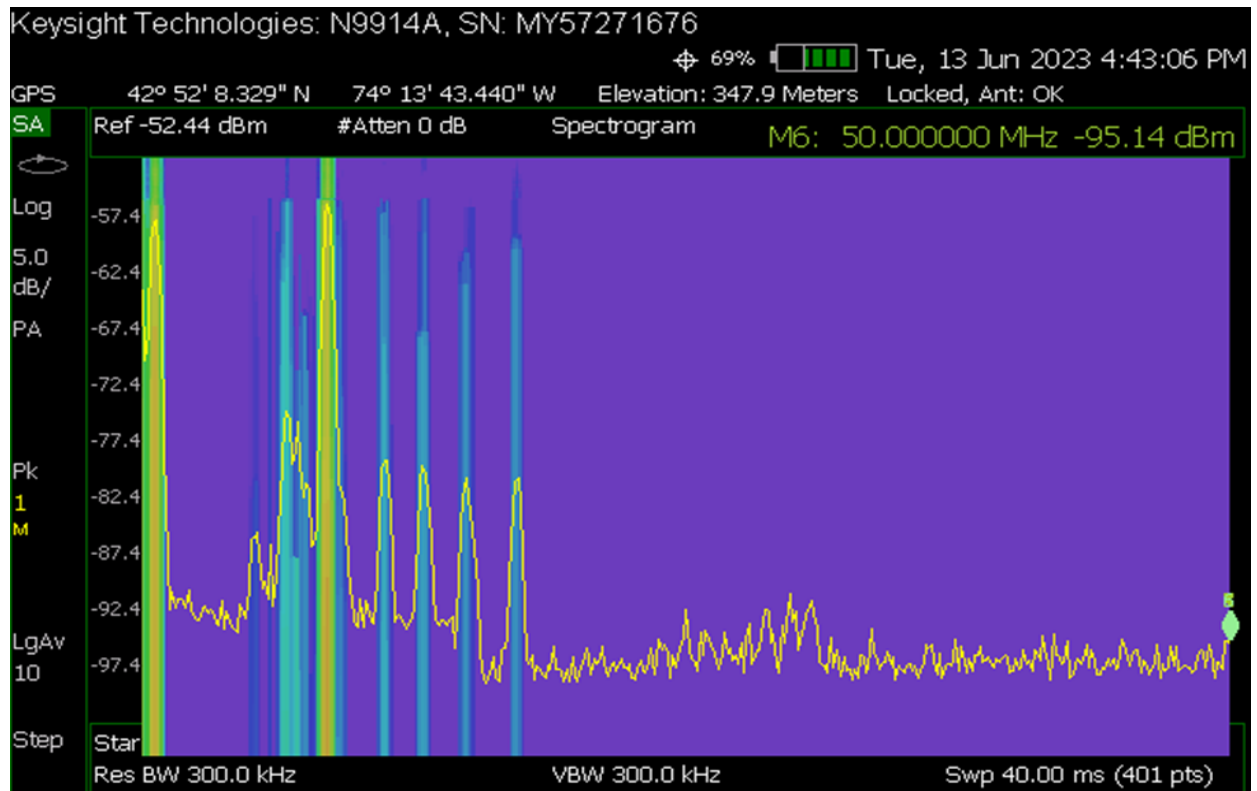

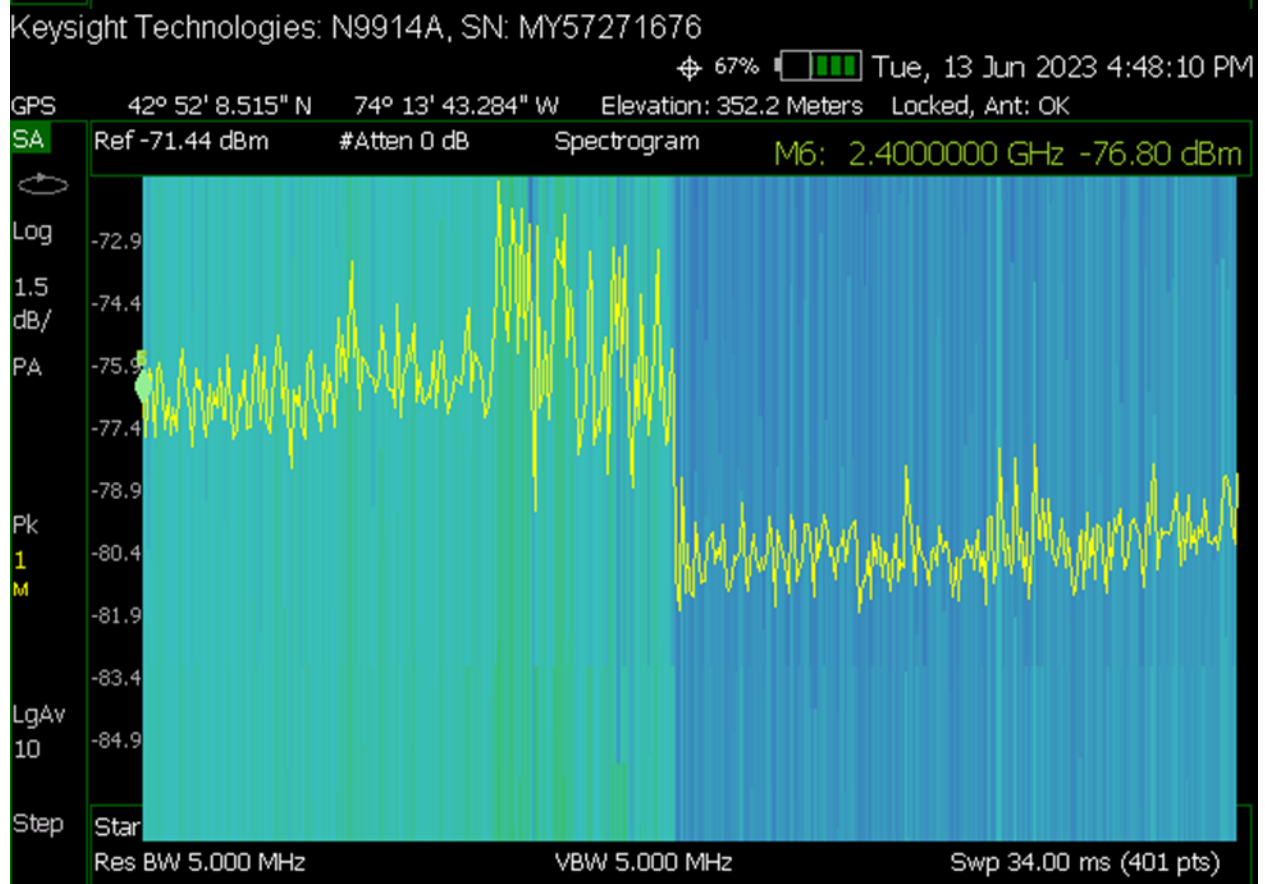
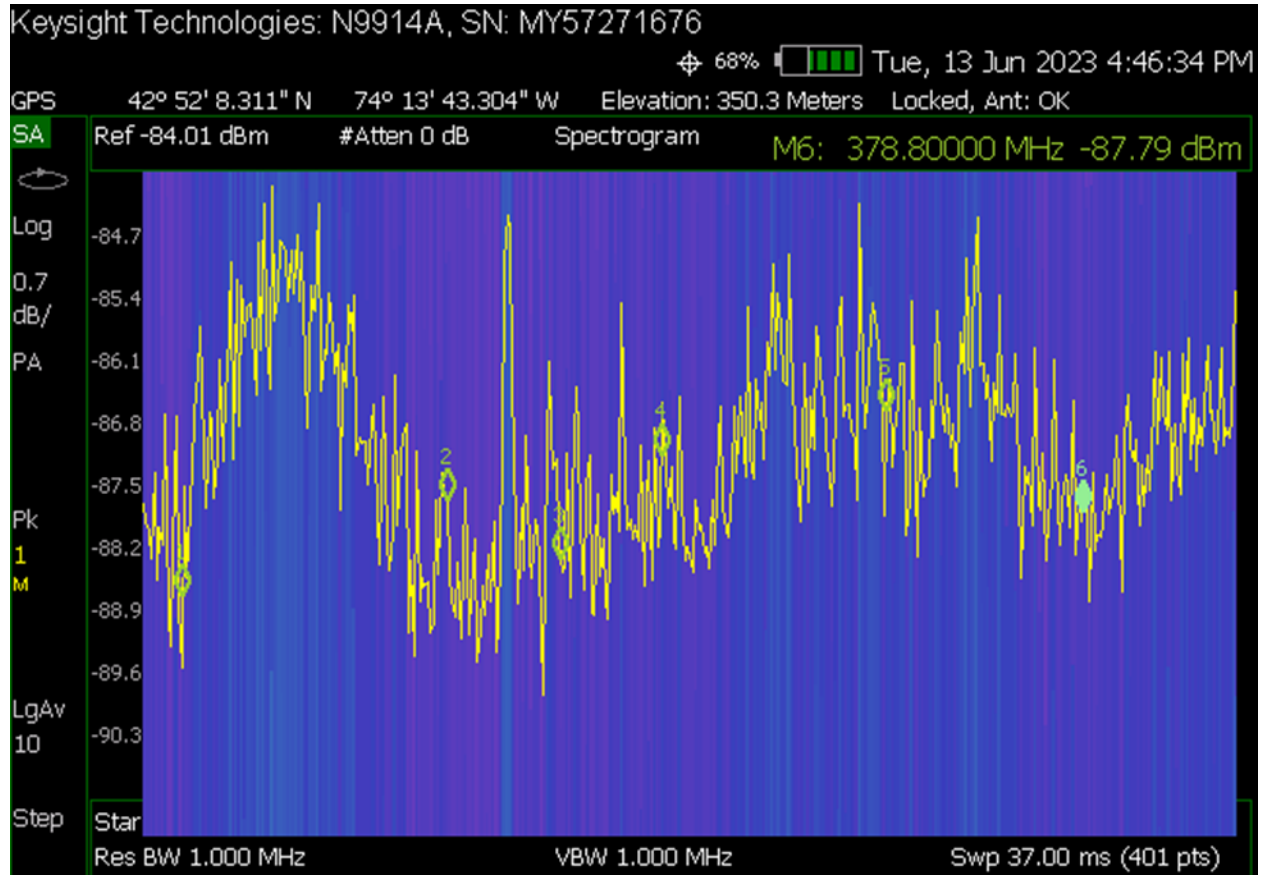

Measurement Location 5

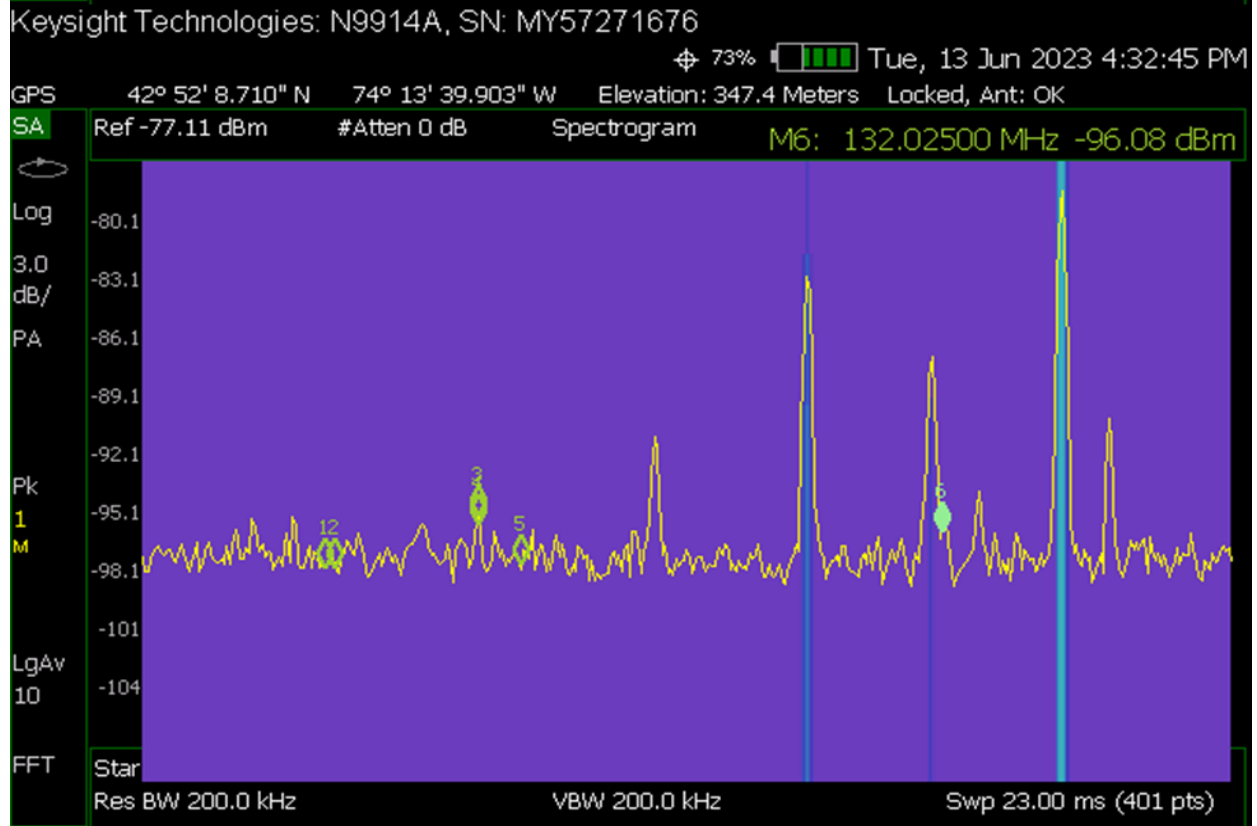
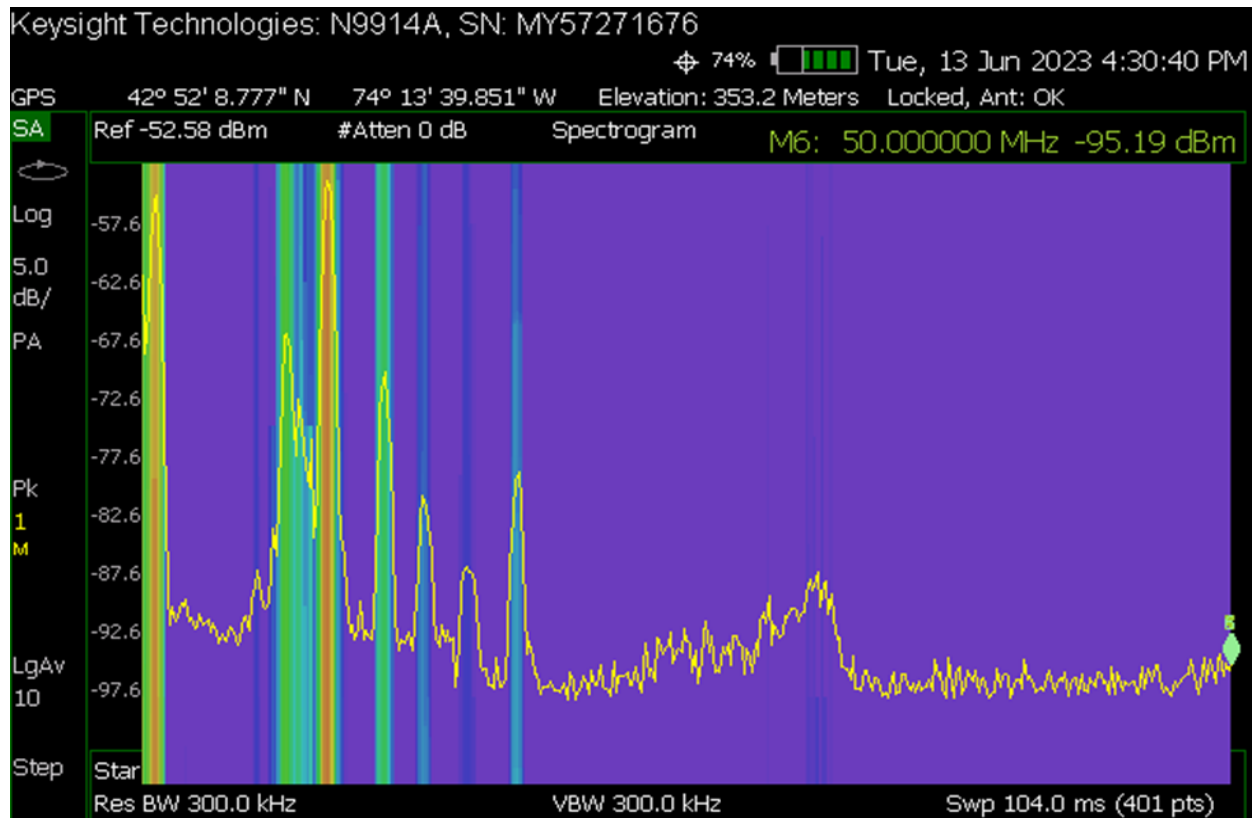

Keysight Technologies: N9914A, SN: MY57271676

72% Tue, 13 Jun 2023 4:34:42 PM

GPS 42° 52' 8.626" N 74° 13' 39.941" W Elevation: 344.9 Meters Locked, Ant: OK

SA Ref -81.80 dBm #Atten 0 dB Spectrogram M6: 378.80000 MHz -88.61 dBm

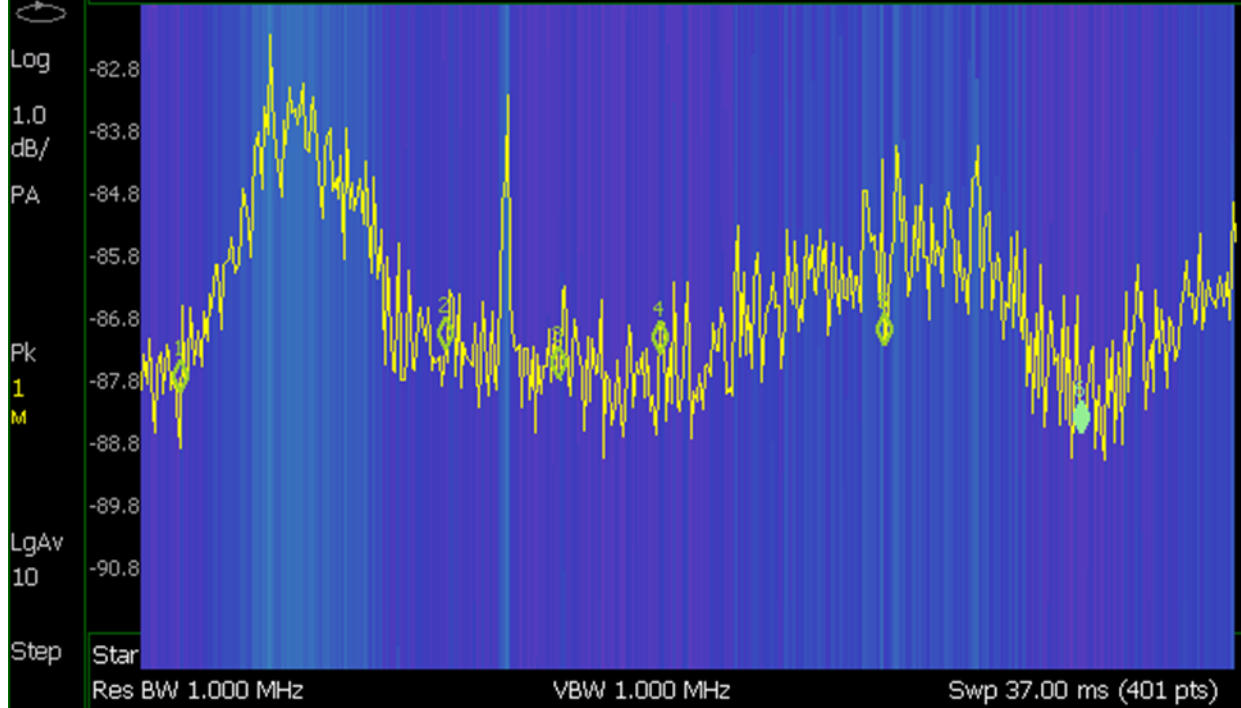

Keysight Technologies: N9914A, SN: MY57271676

72% Tue, 13 Jun 2023 4:35:36 PM

GPS 42° 52' 8.735" N 74° 13' 39.941" W Elevation: 350.1 Meters Locked, Ant: OK

SA Ref -73.26 dBm #Atten 0 dB Spectrogram M6: 2.4000000 GHz -77.02 dBm

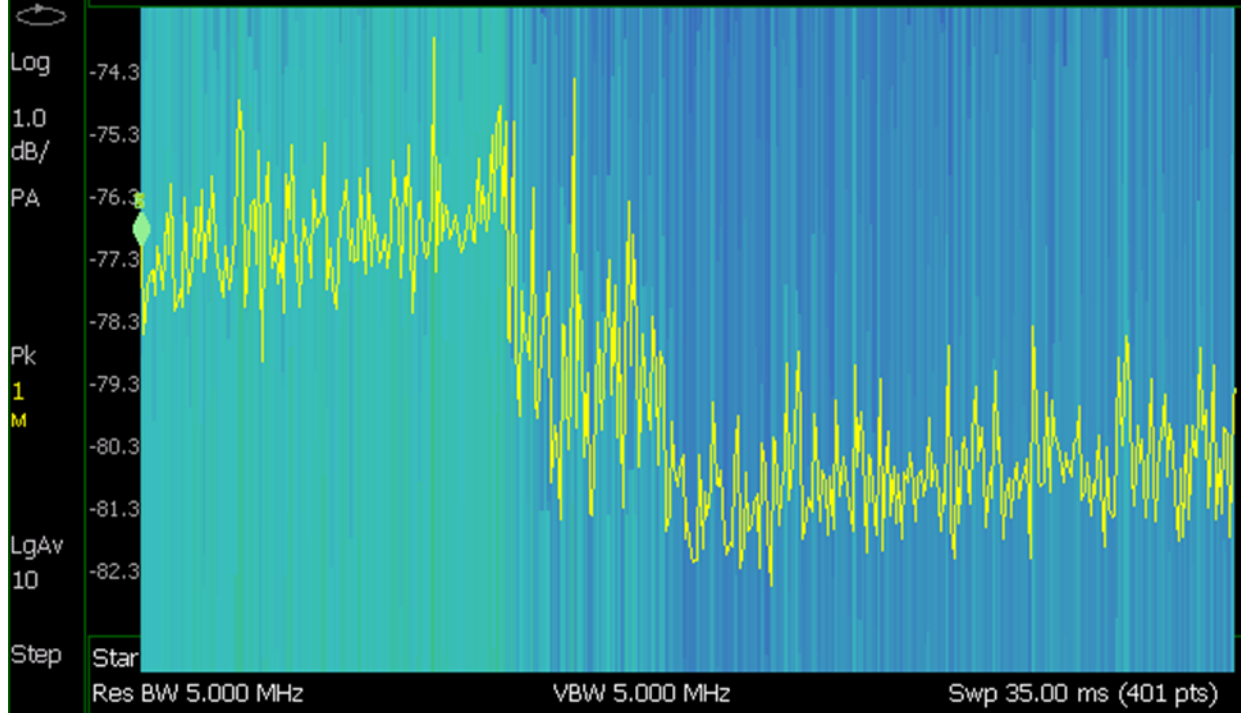

Measurement Location 6

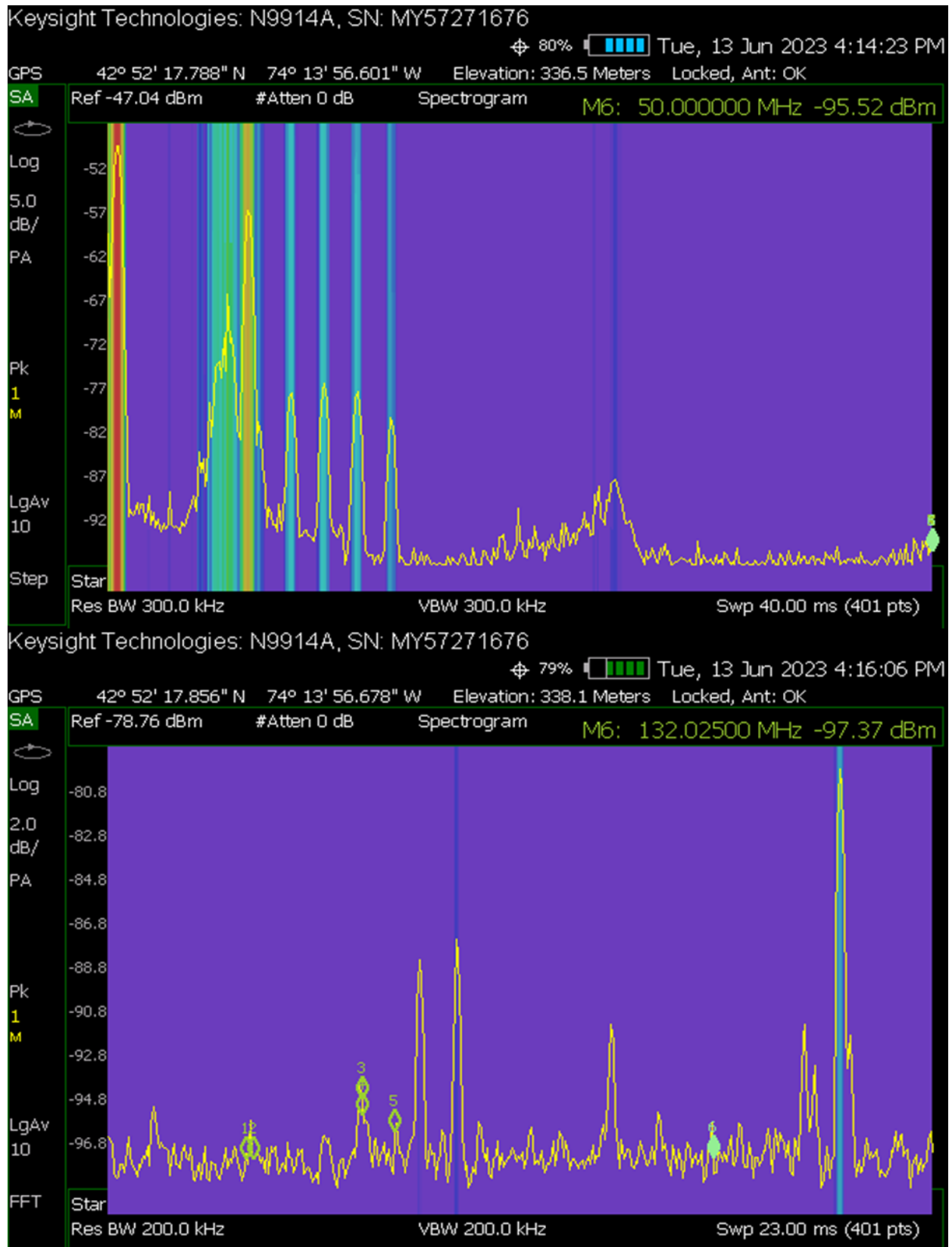

Keysight Technologies: N9914A, SN: MY57271676

79%  Tue, 13 Jun 2023 4:17:46 PM

GPS 42° 52' 17.861" N 74° 13' 56.625" W Elevation: 335.3 Meters Locked, Ant: OK

SA Ref -81.71 dBm #Atten 0 dB Spectrogram M6: 378.80000 MHz -87.92 dBm

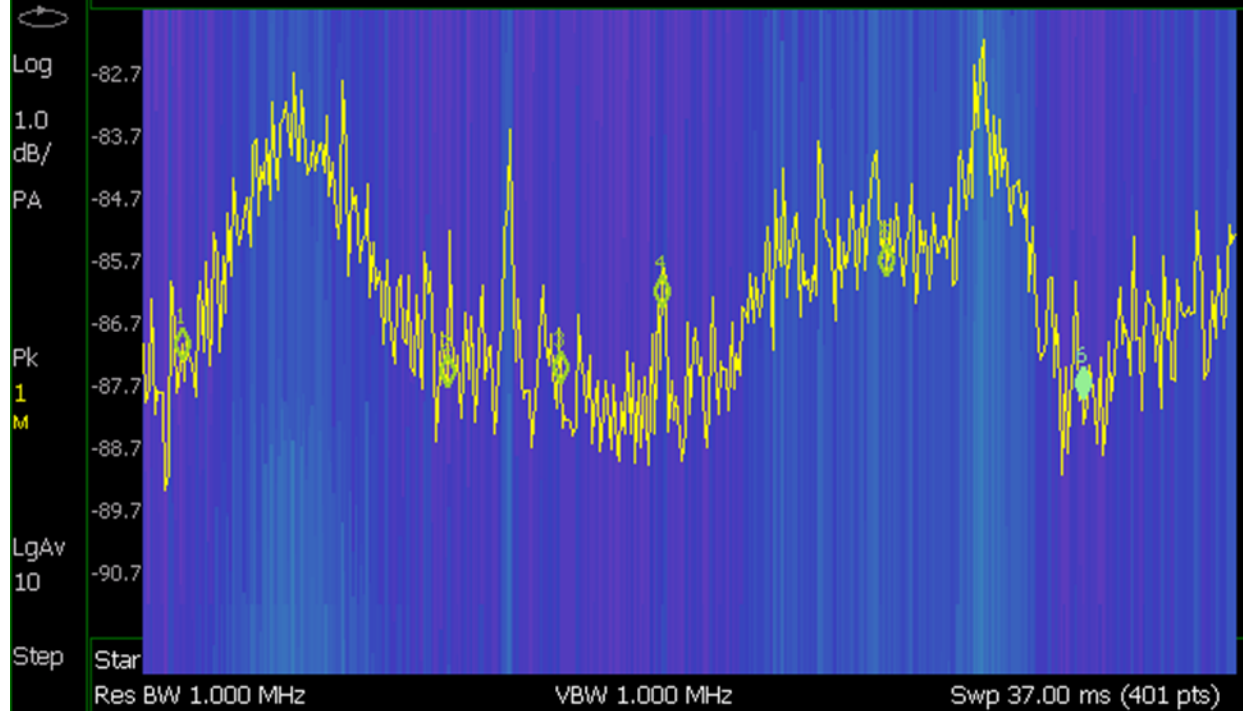

Keysight Technologies: N9914A, SN: MY57271676

78%  Tue, 13 Jun 2023 4:18:57 PM

GPS 42° 52' 17.875" N 74° 13' 56.637" W Elevation: 339.5 Meters Locked, Ant: OK

SA Ref -70.39 dBm #Atten 0 dB Spectrogram M6: 2.4000000 GHz -77.39 dBm

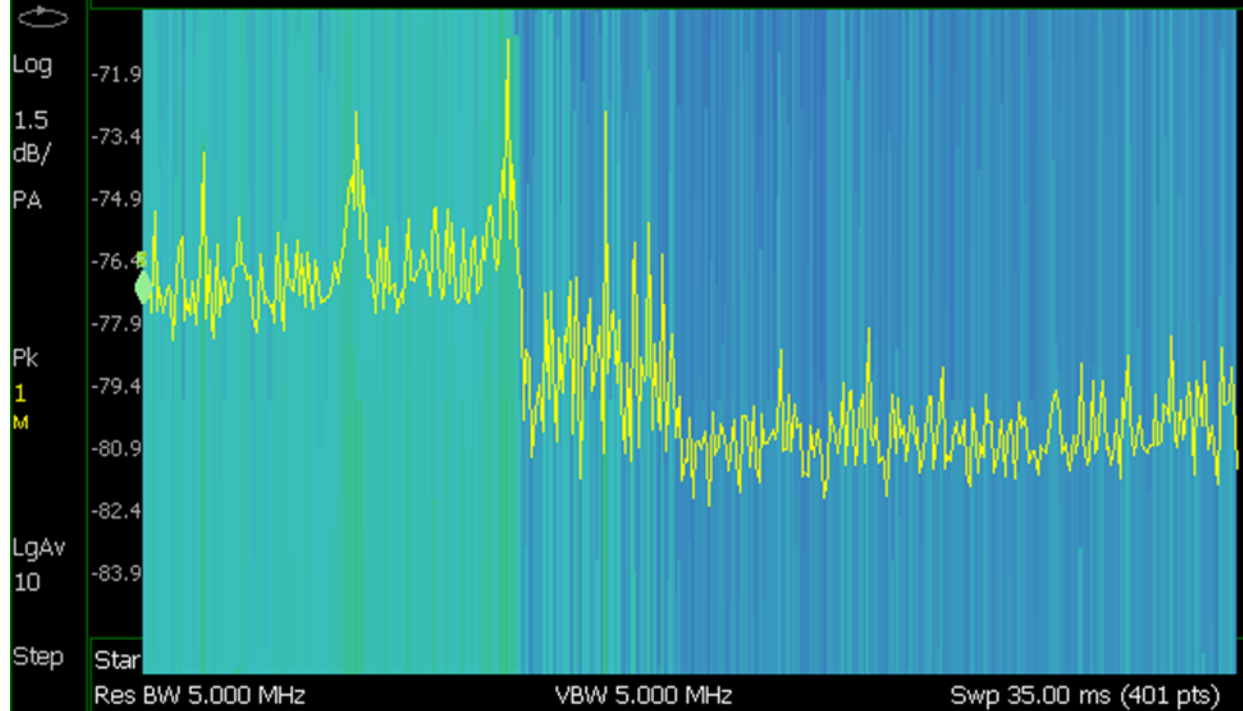

Measurement Location 7

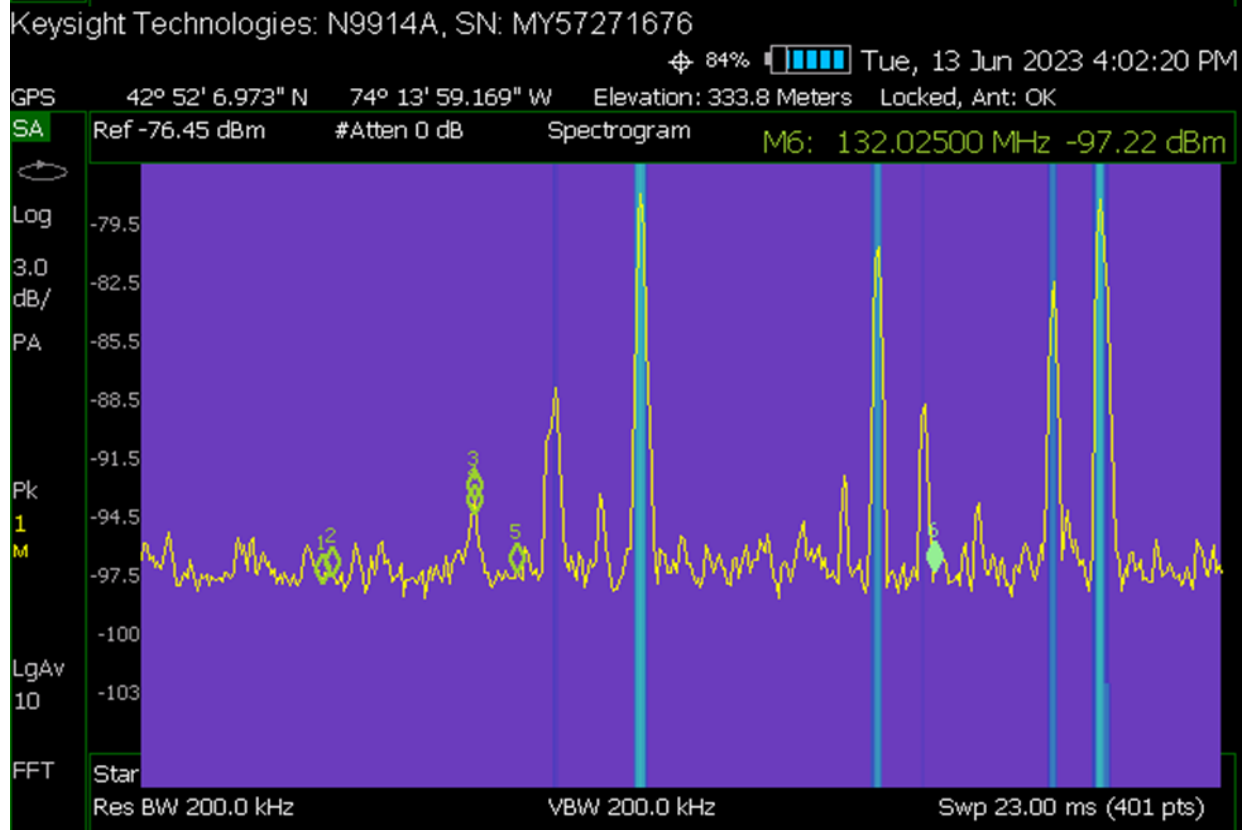
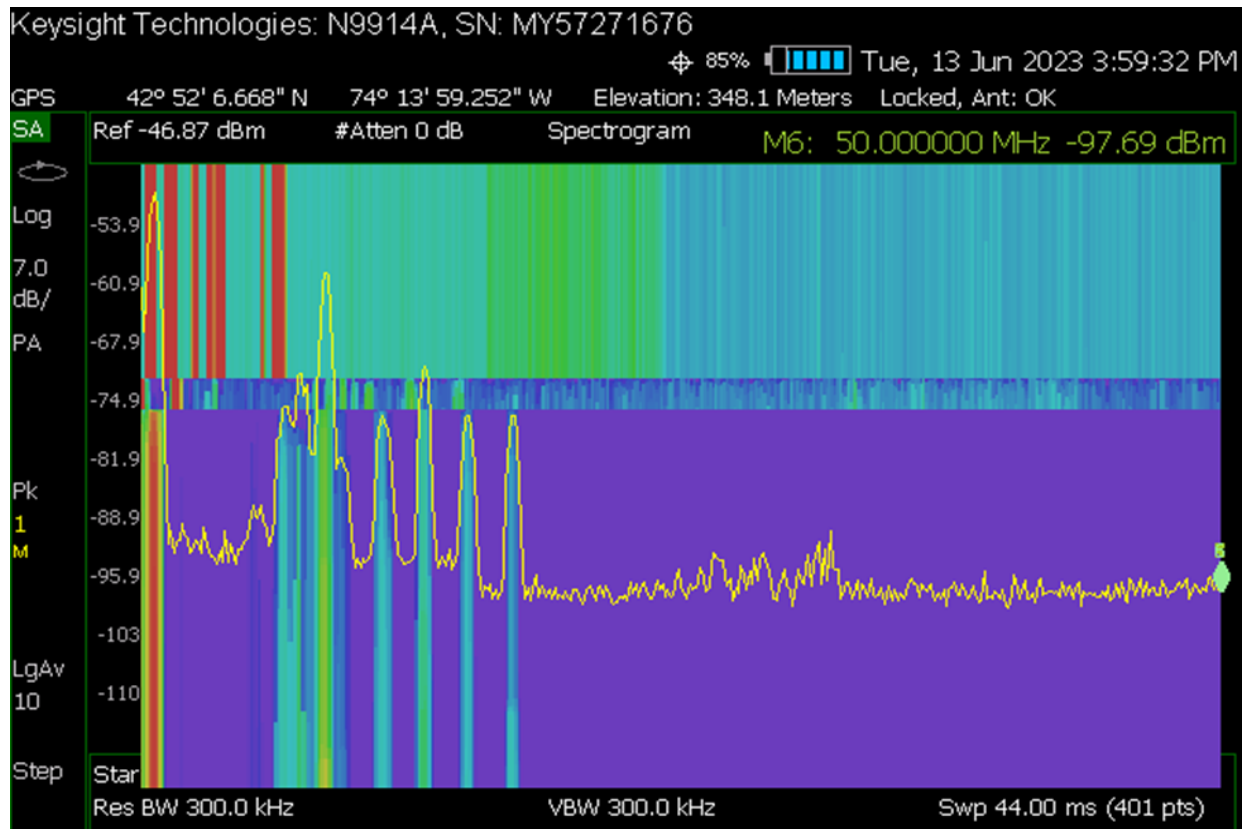

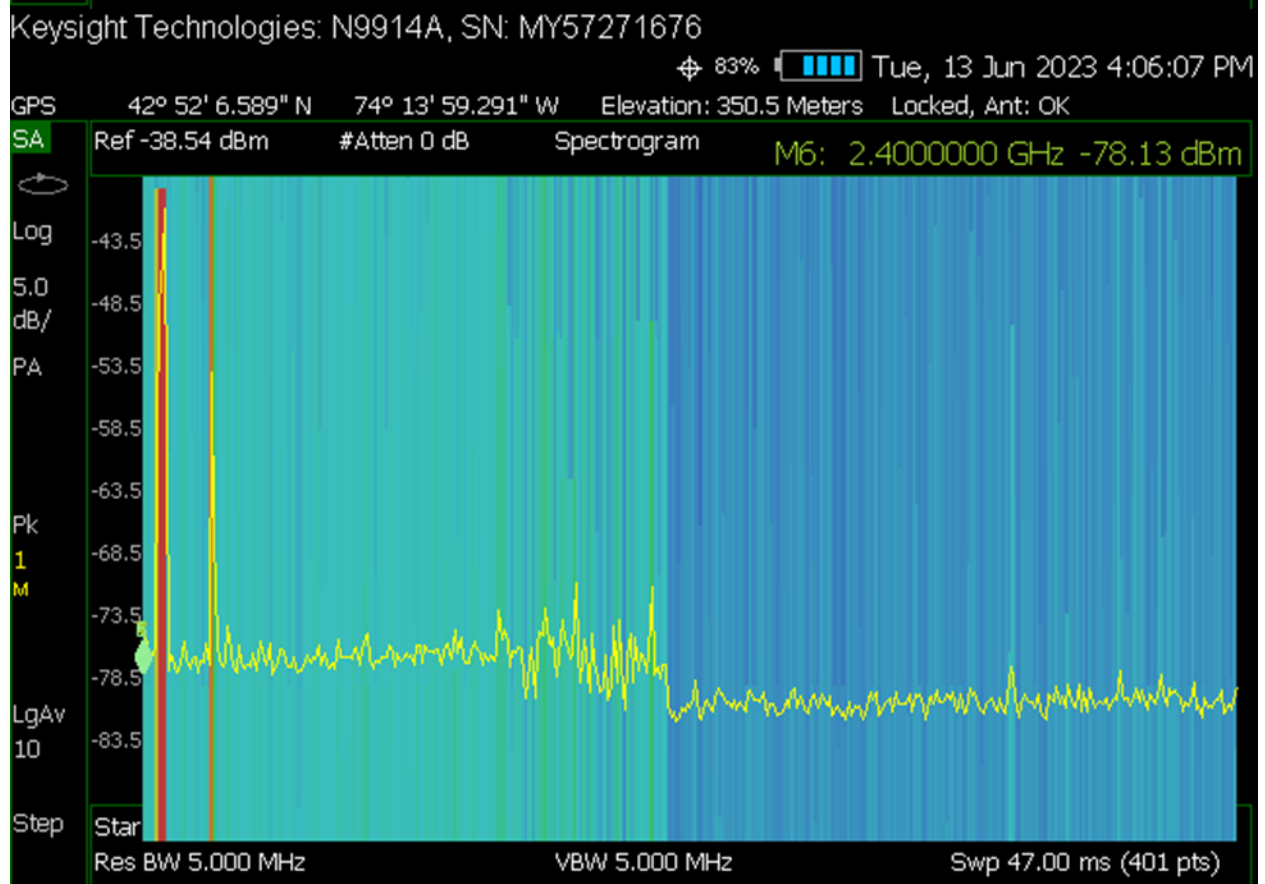
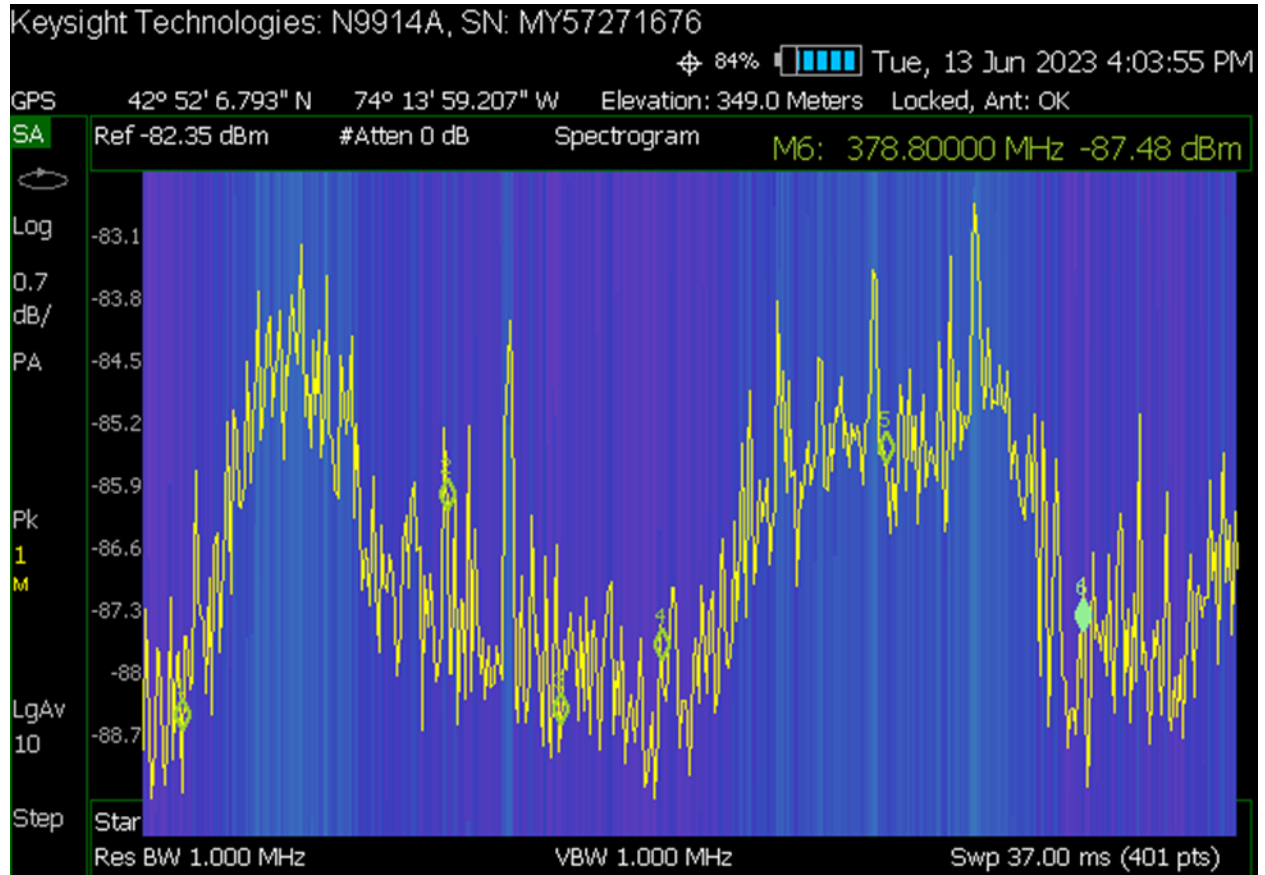

Measurement Location 8

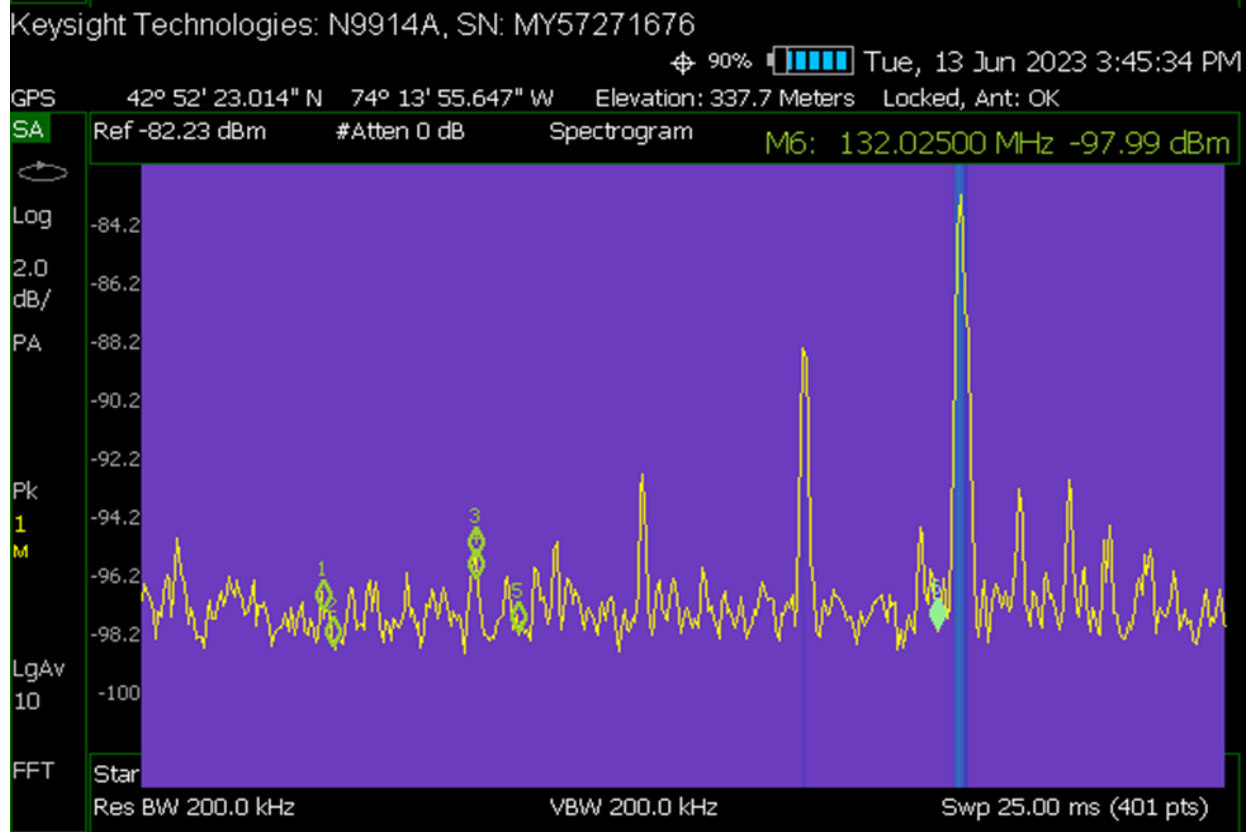
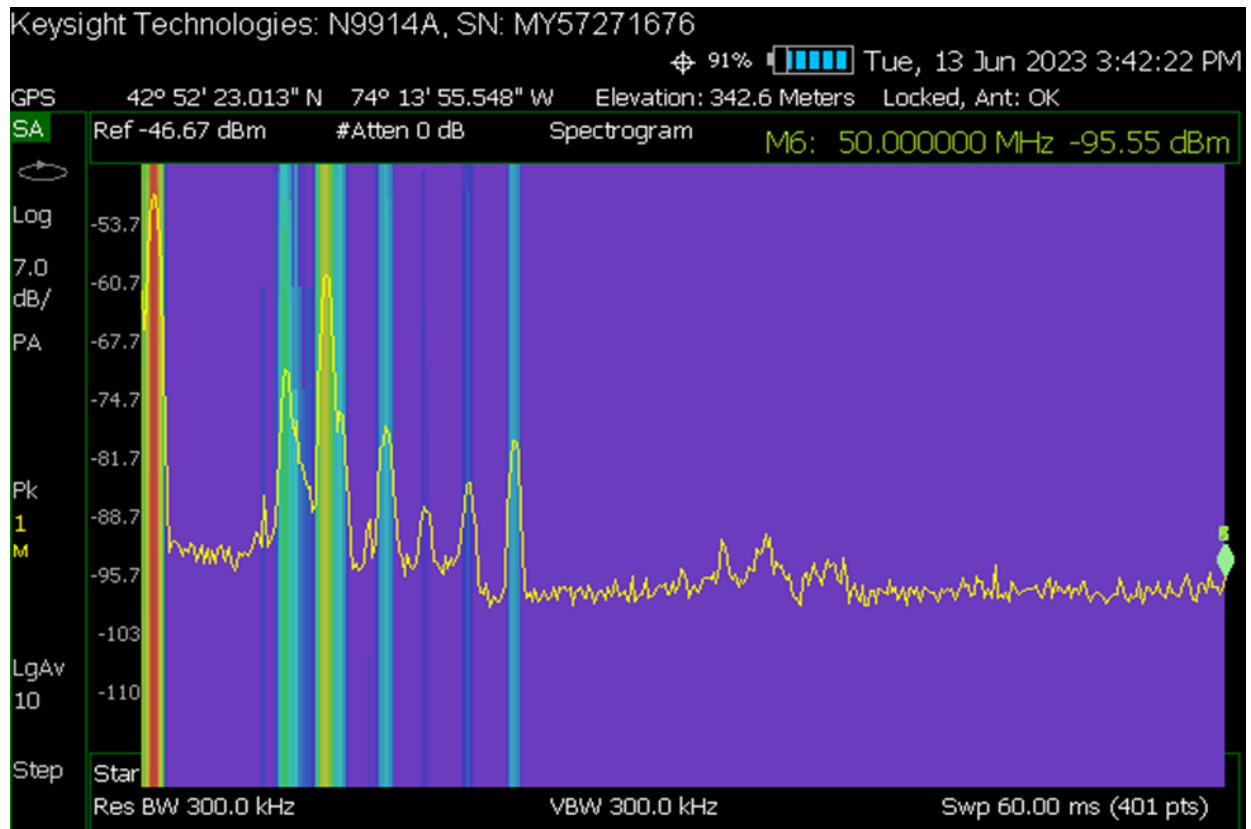

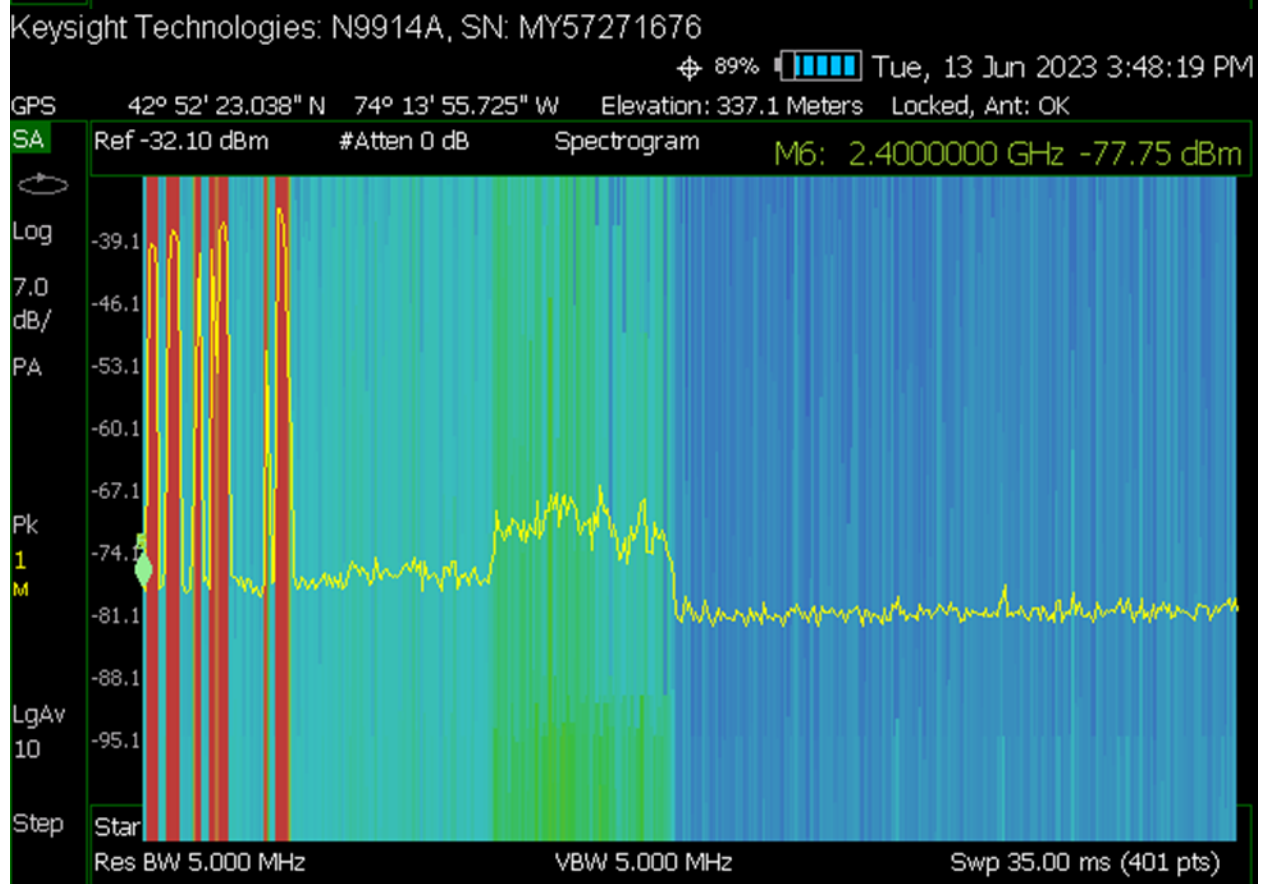
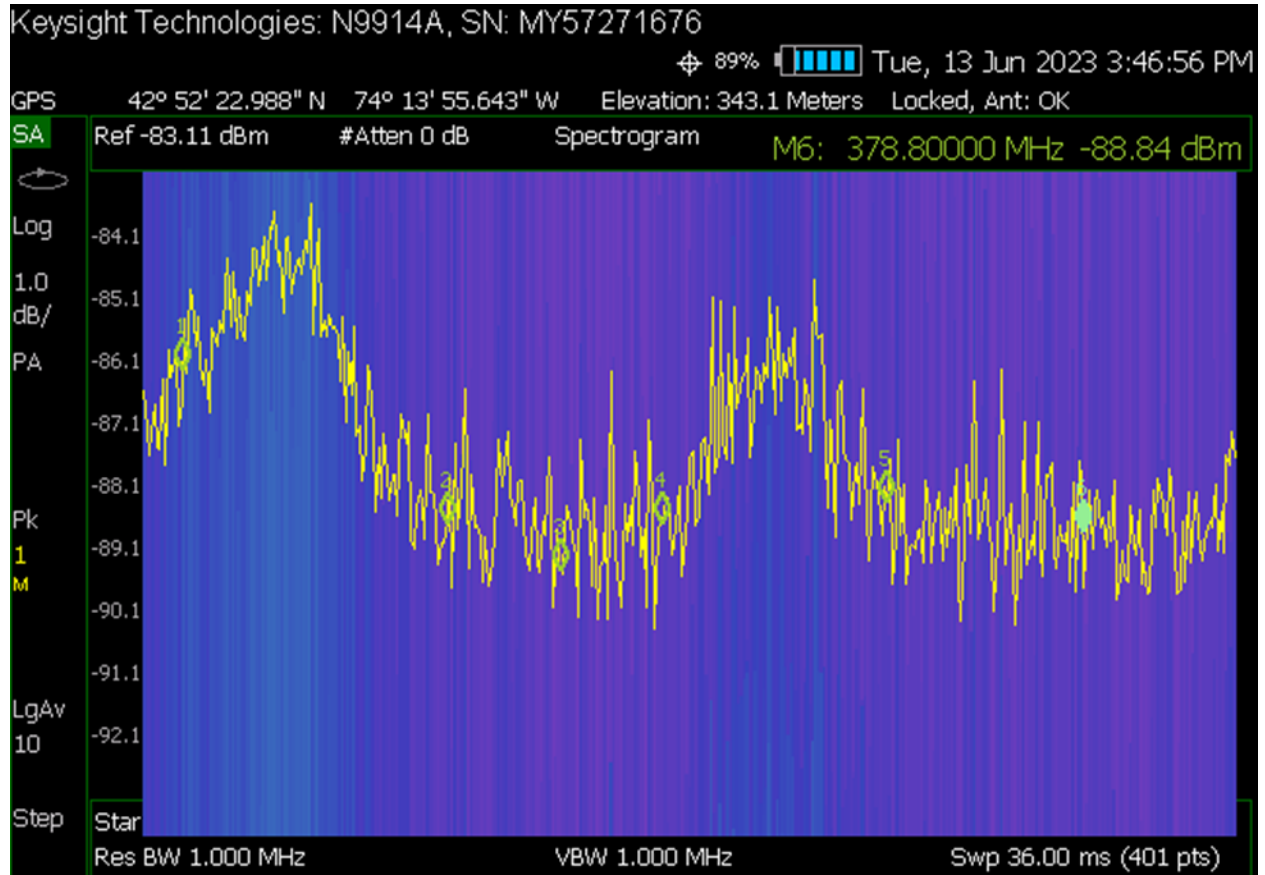

Measurement Location 9

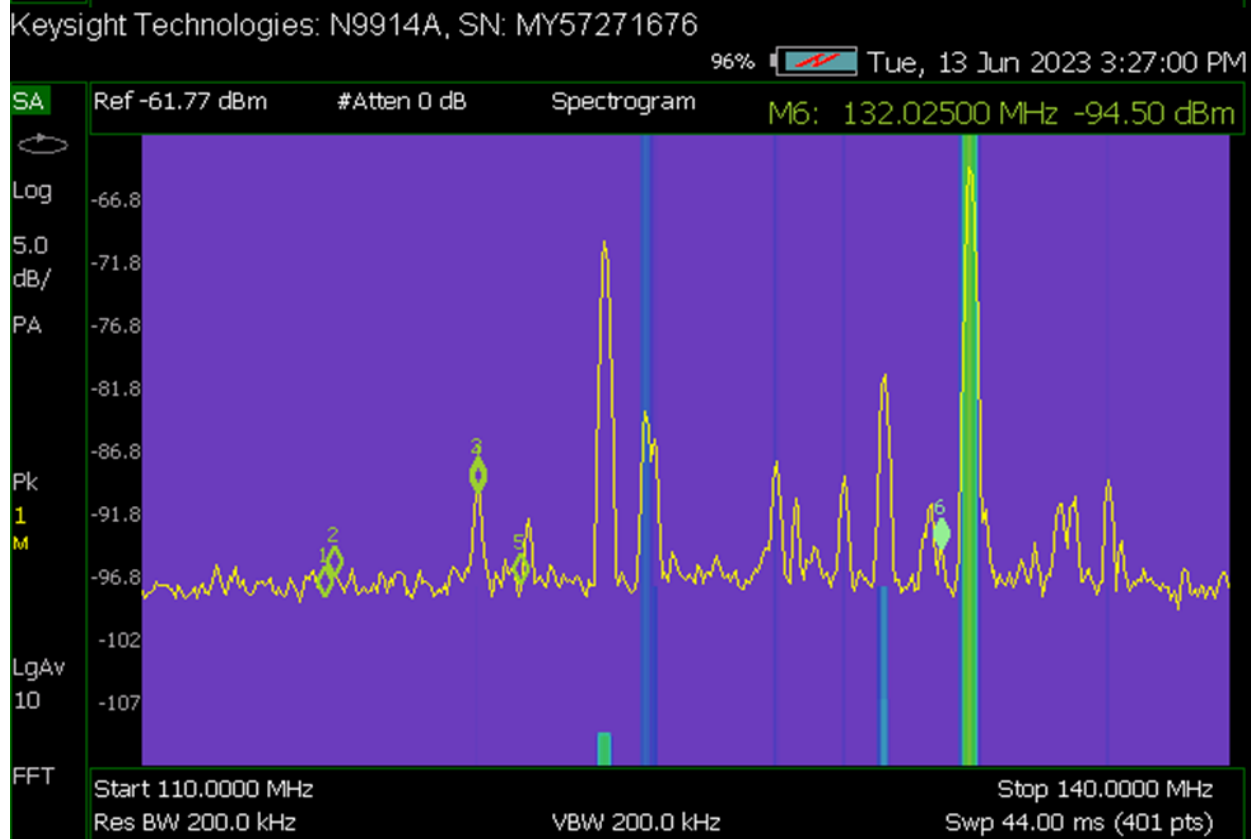
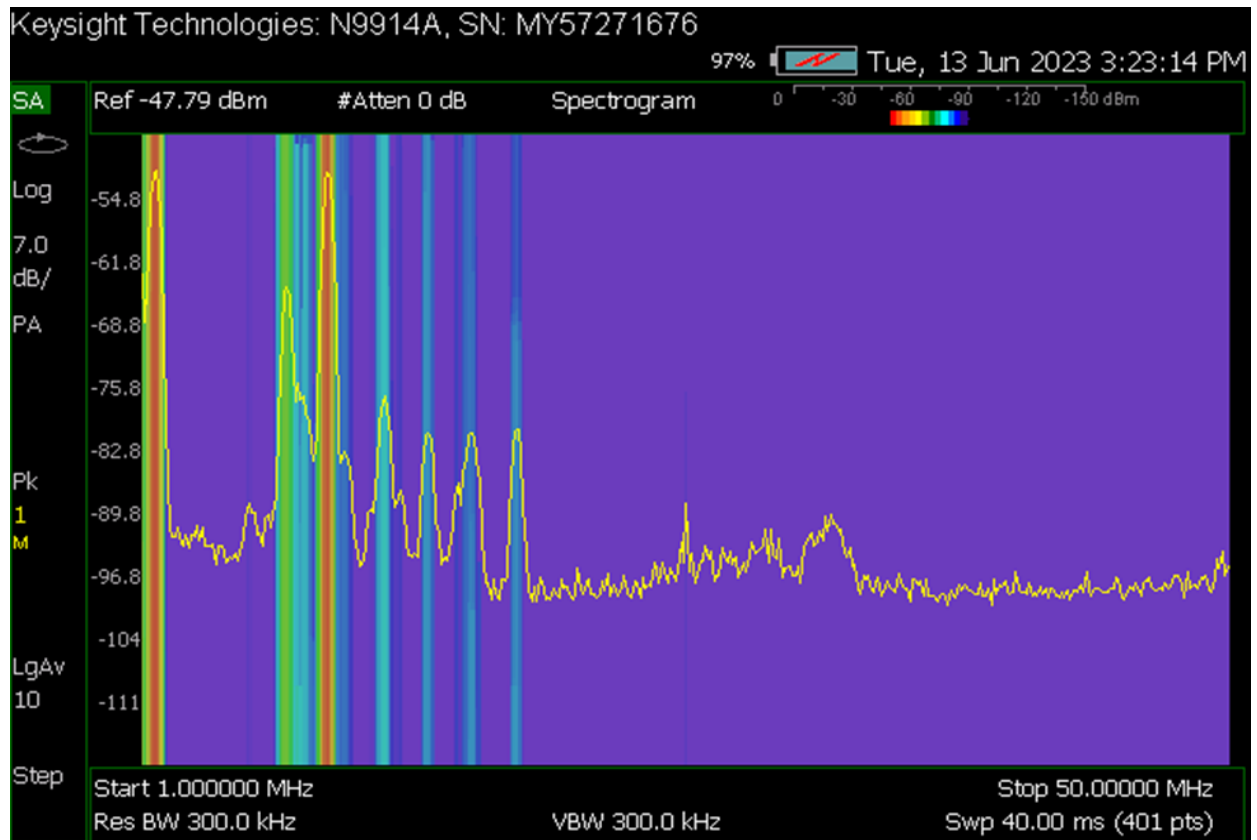

Keysight Technologies: N9914A, SN: MY57271676

96%  Tue, 13 Jun 2023 3:28:31 PM

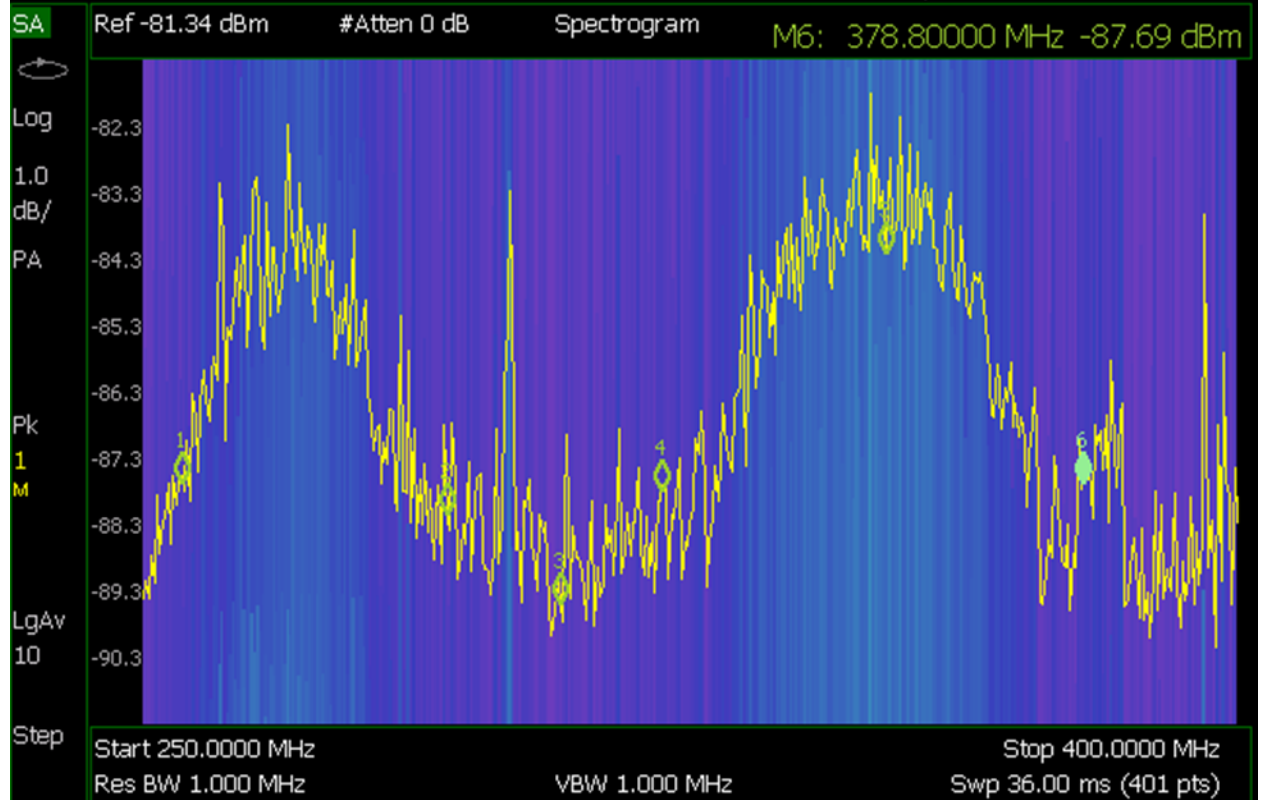

Keysight Technologies: N9914A, SN: MY57271676

95%  Tue, 13 Jun 2023 3:31:53 PM

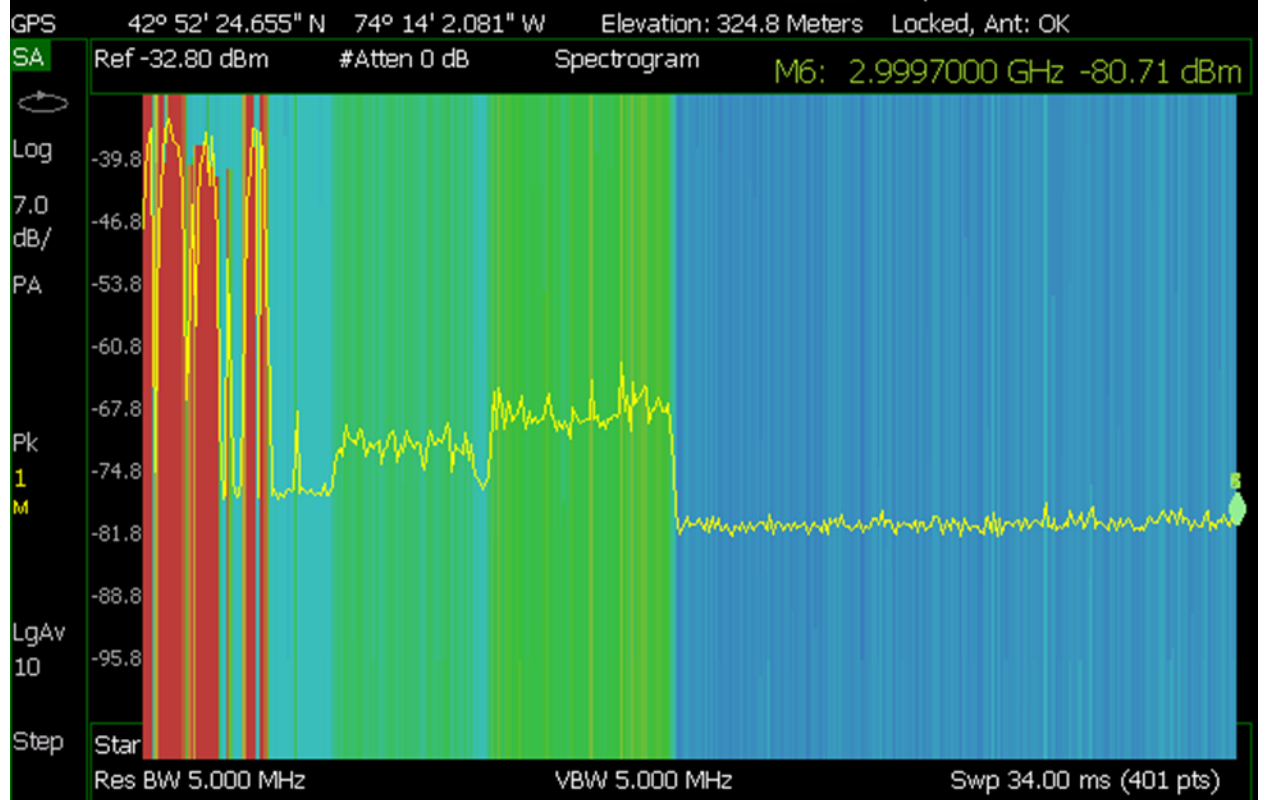

Measurement Location 10

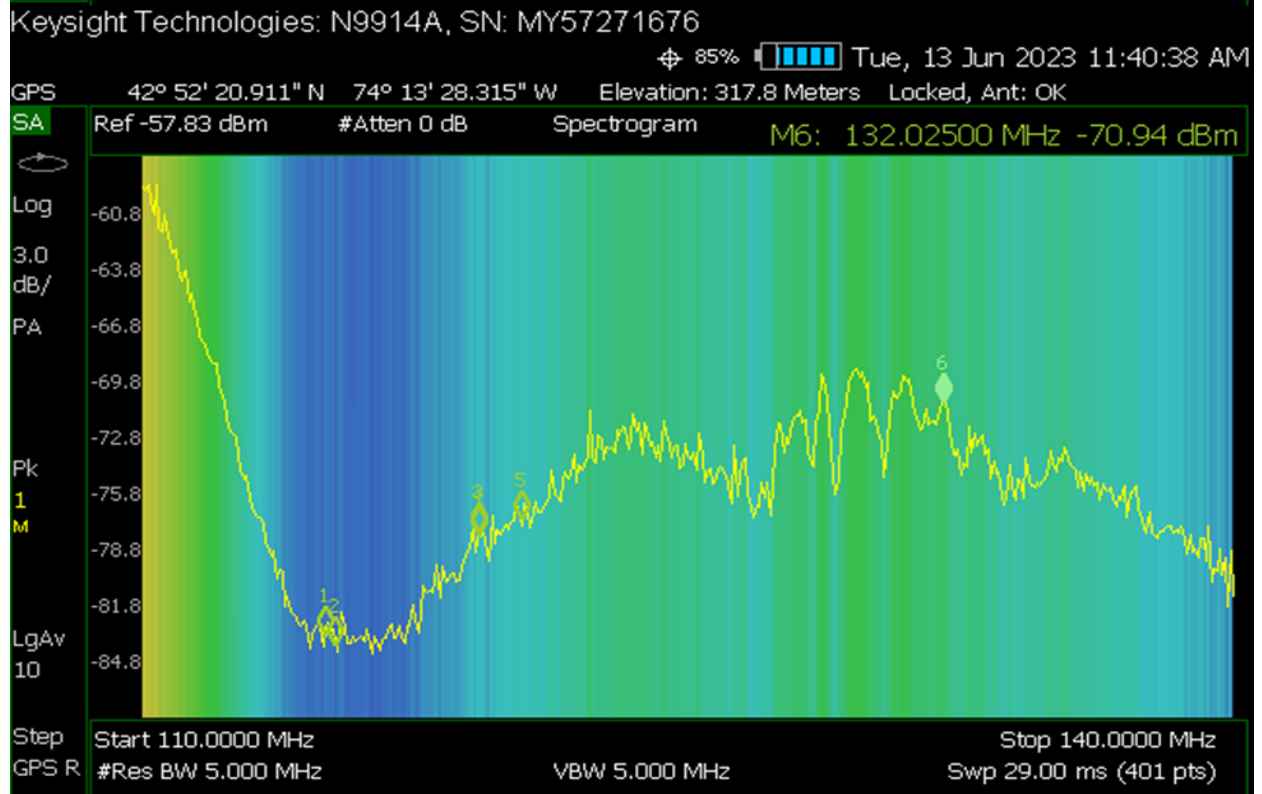
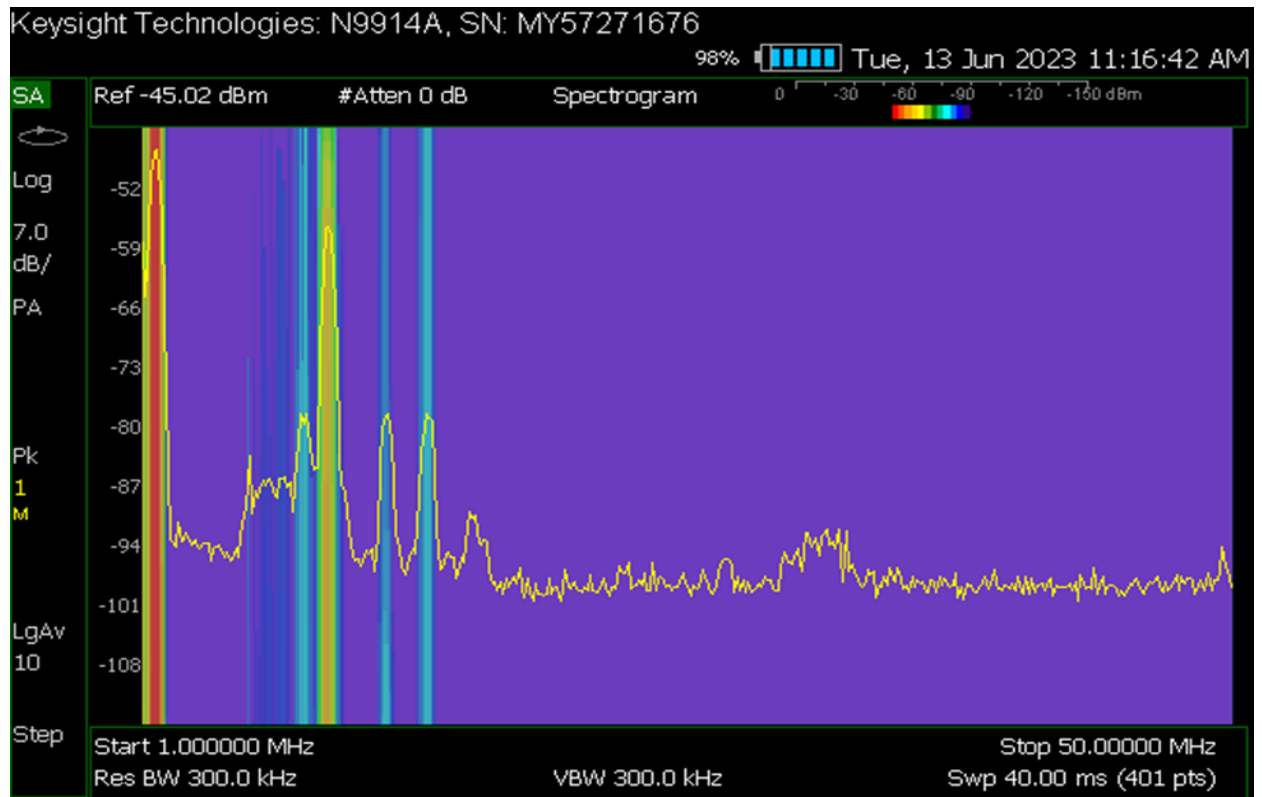

Keysight Technologies: N9914A, SN: MY57271676

83% Tue, 13 Jun 2023 11:44:19 AM

GPS 42° 52' 20.882" N 74° 13' 28.135" W Elevation: 321.0 Meters Locked, Ant: OK

SA Ref -57.83 dBm #Atten 0 dB Spectrogram M6: 378.80000 MHz -81.39 dBm

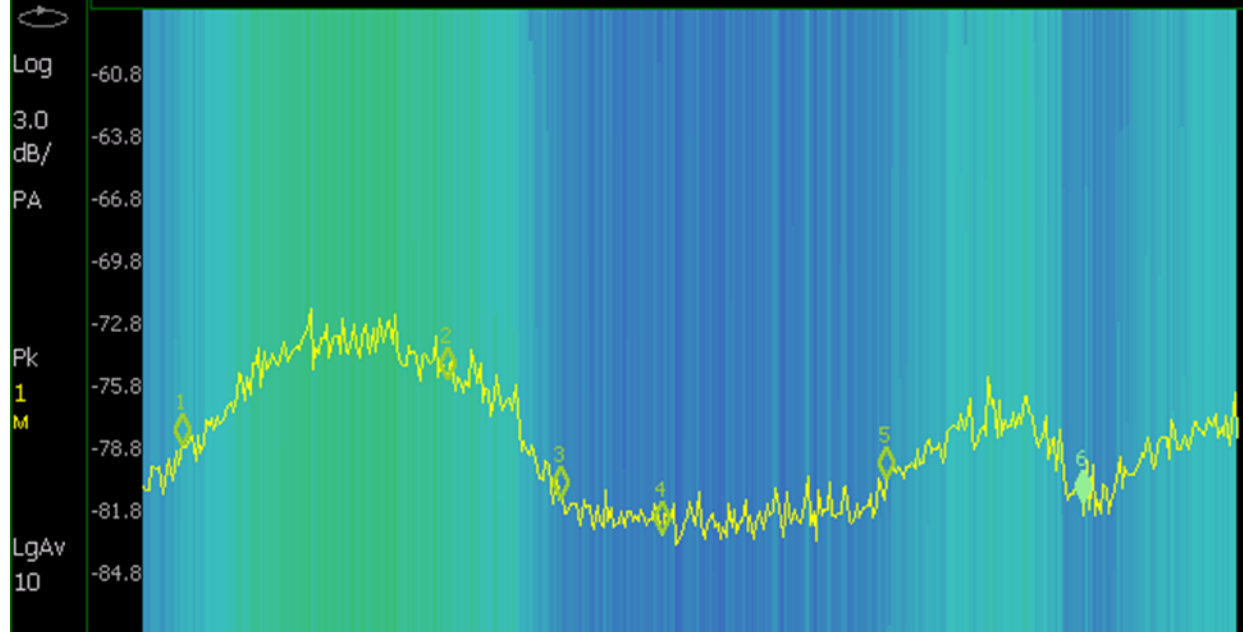

Step Start 250.0000 MHz Stop 400.0000 MHz
GPS R #Res BW 5.000 MHz VBW 5.000 MHz Swp 28.00 ms (401 pts)

Keysight Technologies: N9914A, SN: MY57271676

82% Tue, 13 Jun 2023 11:46:49 AM

GPS 42° 52' 20.806" N 74° 13' 28.193" W Elevation: 322.4 Meters Locked, Ant: OK

SA Ref -62.91 dBm #Atten 0 dB Spectrogram M6: 2.3250000 GHz -78.39 dBm



Step Start 2.325000 GHz Stop 3.000000 GHz
GPS R #Res BW 5.000 MHz VBW 5.000 MHz Swp 34.00 ms (401 pts)

Measurement Location 11

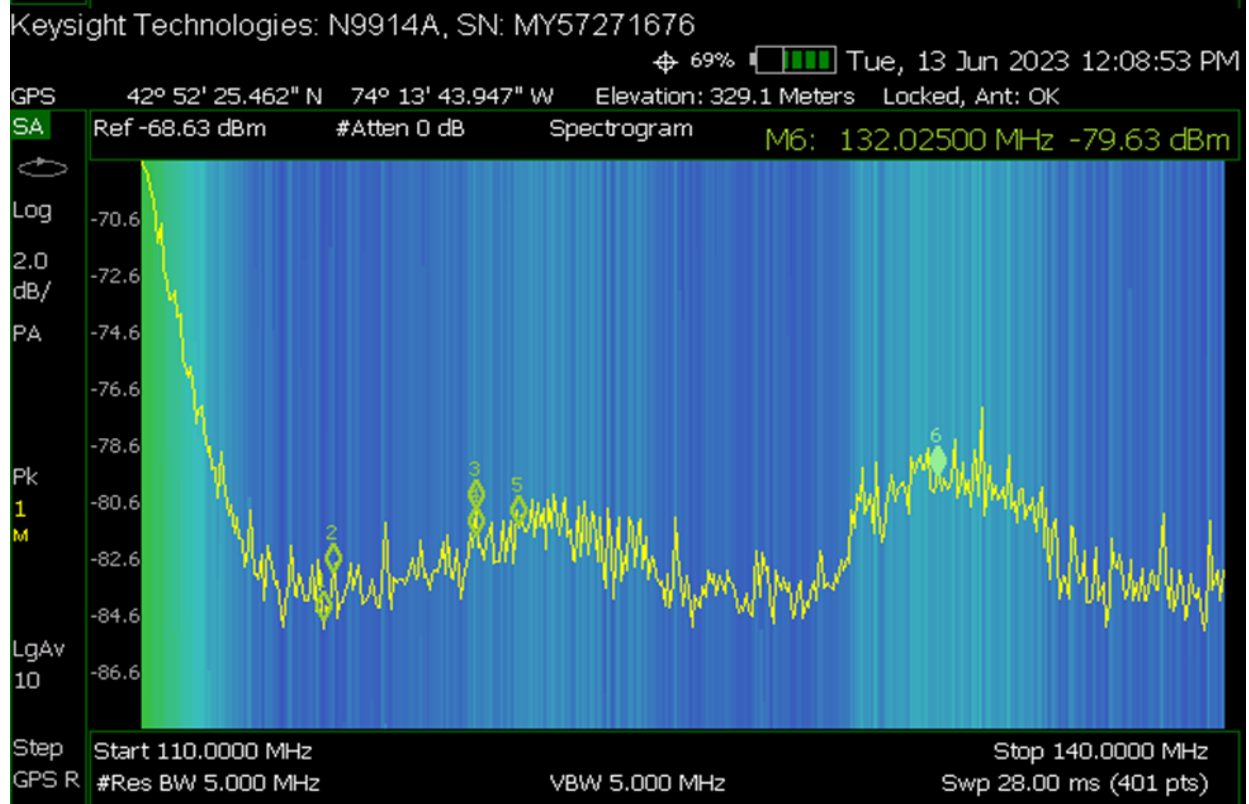
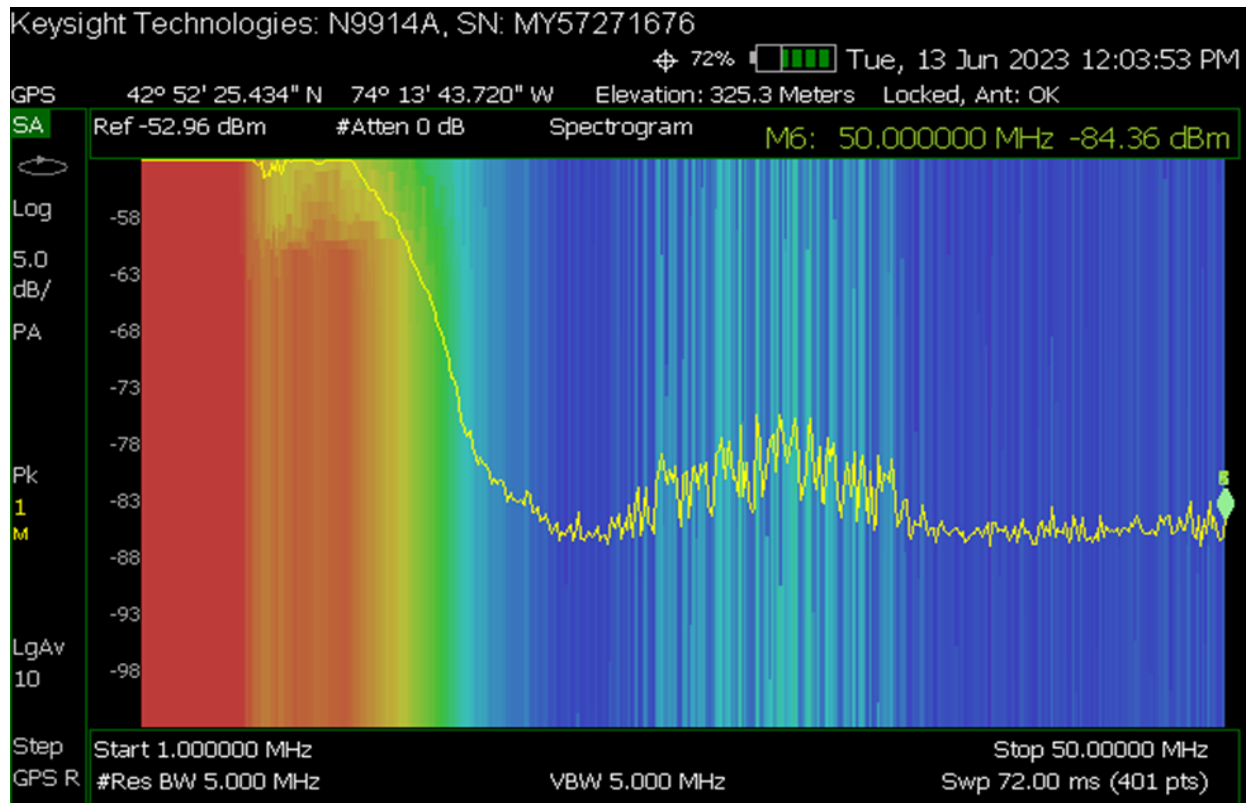

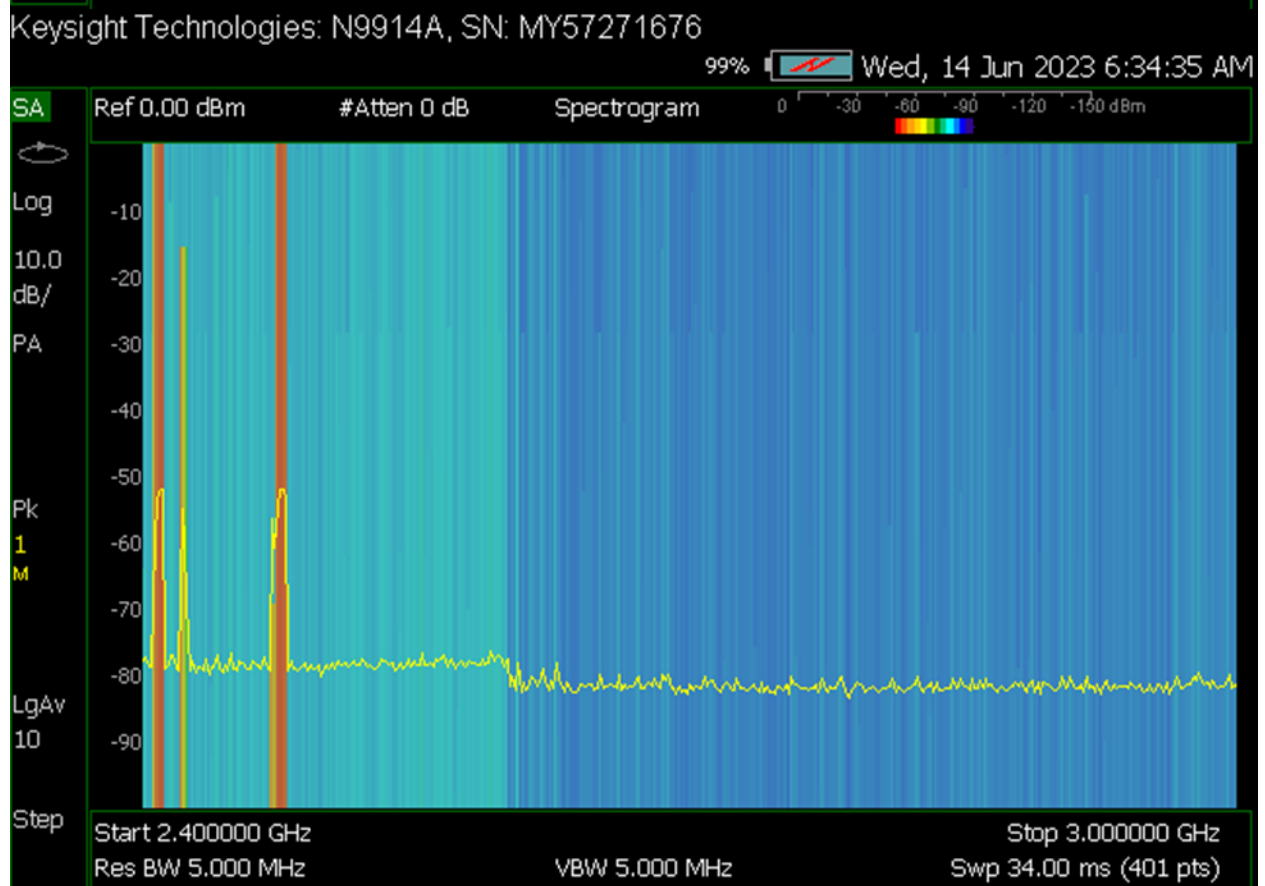
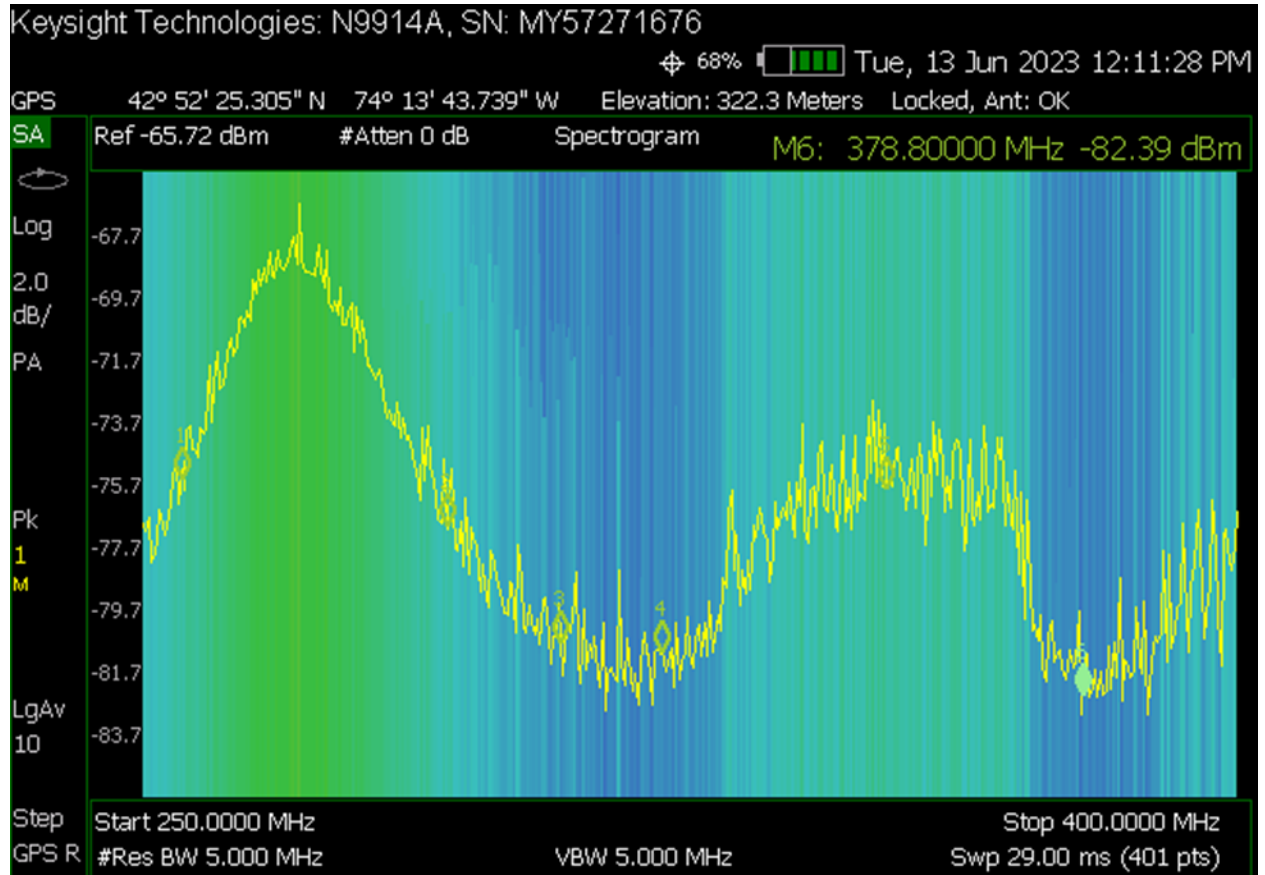

Measurement Location 12

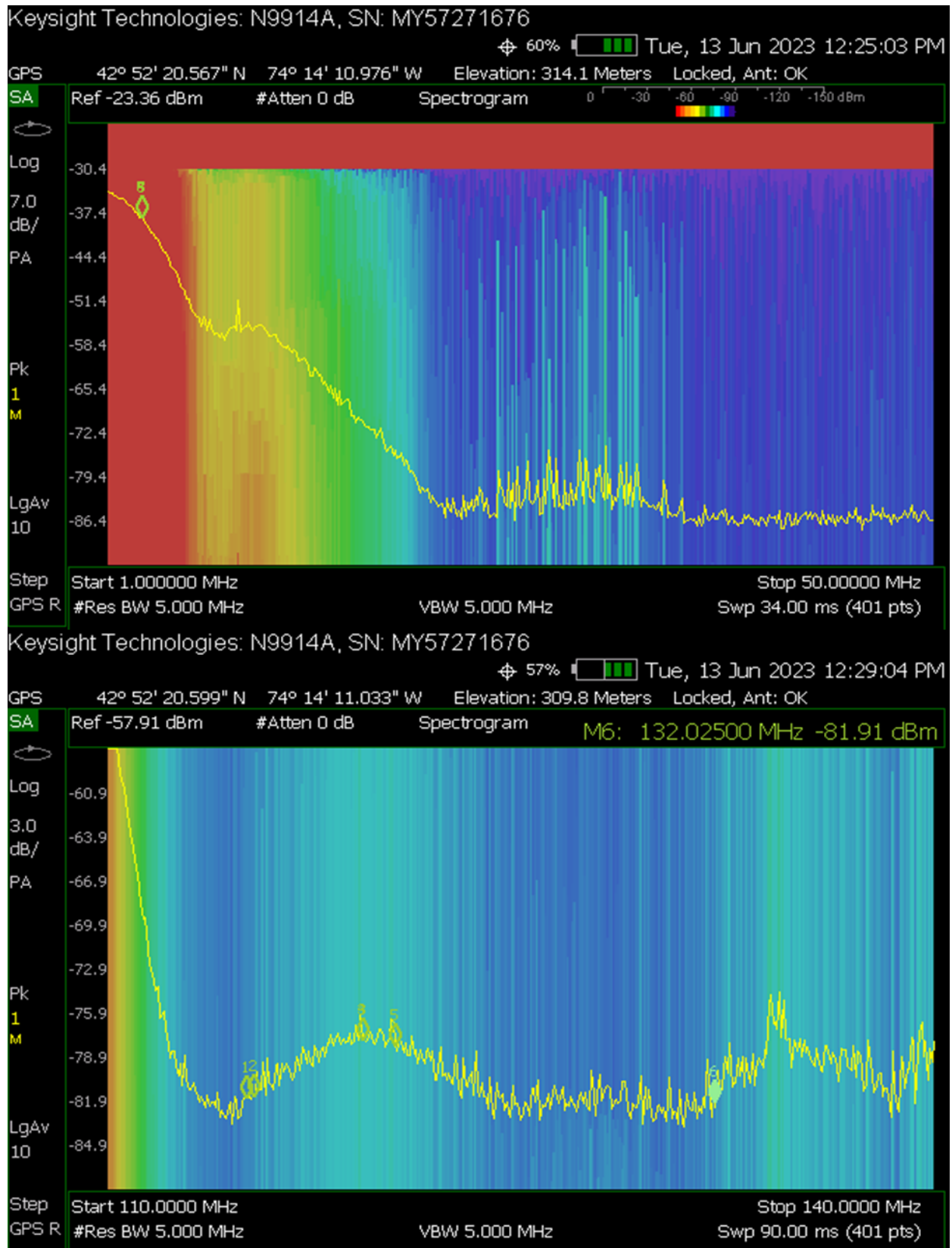

Keysight Technologies: N9914A, SN: MY57271676

56% Tue, 13 Jun 2023 12:30:50 PM

GPS 42° 52' 20.497" N 74° 14' 11.171" W Elevation: 323.2 Meters Locked, Ant: OK

SA Ref -57.91 dBm #Atten 0 dB Spectrogram M6: 378.80000 MHz -78.97 dBm

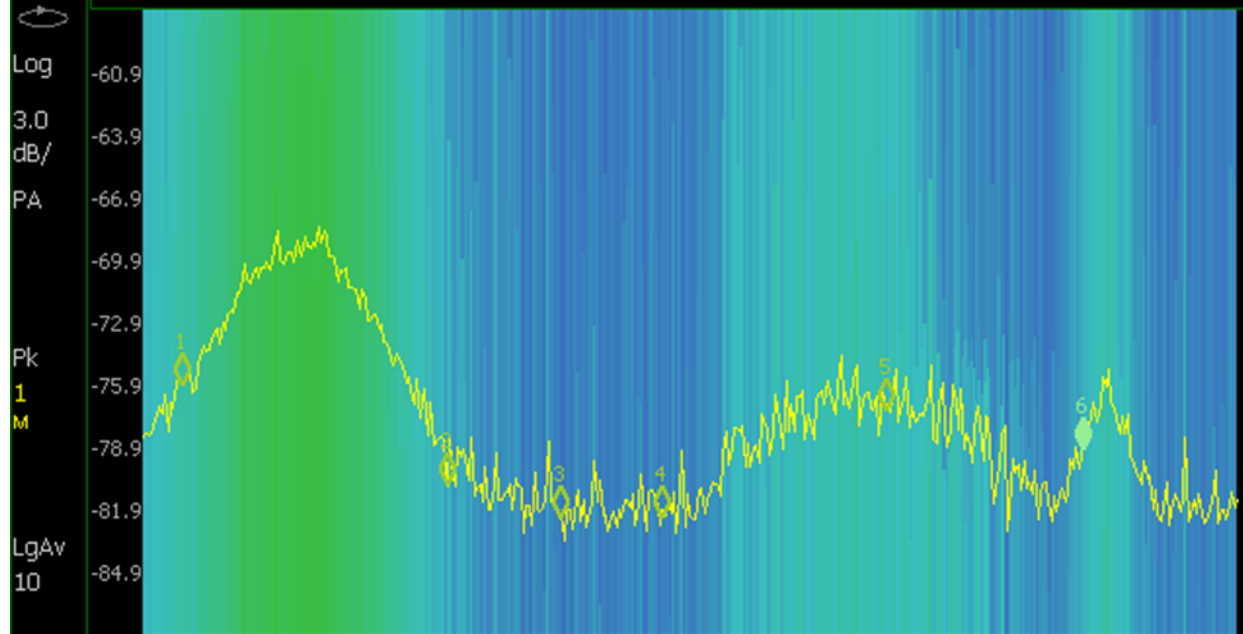

Step Start 250.0000 MHz Stop 400.0000 MHz
GPS R #Res BW 5.000 MHz VBW 5.000 MHz Swp 29.00 ms (401 pts)

Keysight Technologies: N9914A, SN: MY57271676

55% Tue, 13 Jun 2023 12:32:50 PM

GPS 42° 52' 20.491" N 74° 14' 11.179" W Elevation: 322.6 Meters Locked, Ant: OK

SA Ref -57.91 dBm #Atten 0 dB Spectrogram M6: 2.4000000 GHz -77.79 dBm

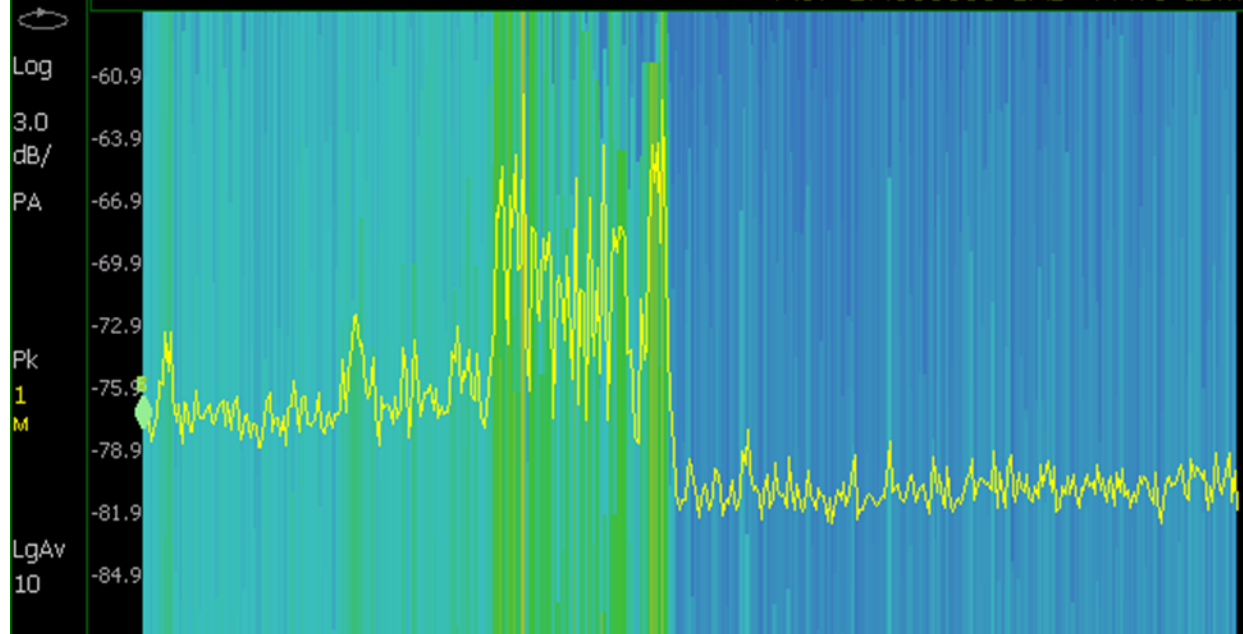

Step Start 2.400000 GHz Stop 3.000000 GHz
GPS R #Res BW 5.000 MHz VBW 5.000 MHz Swp 54.00 ms (401 pts)

Measurement Location 13

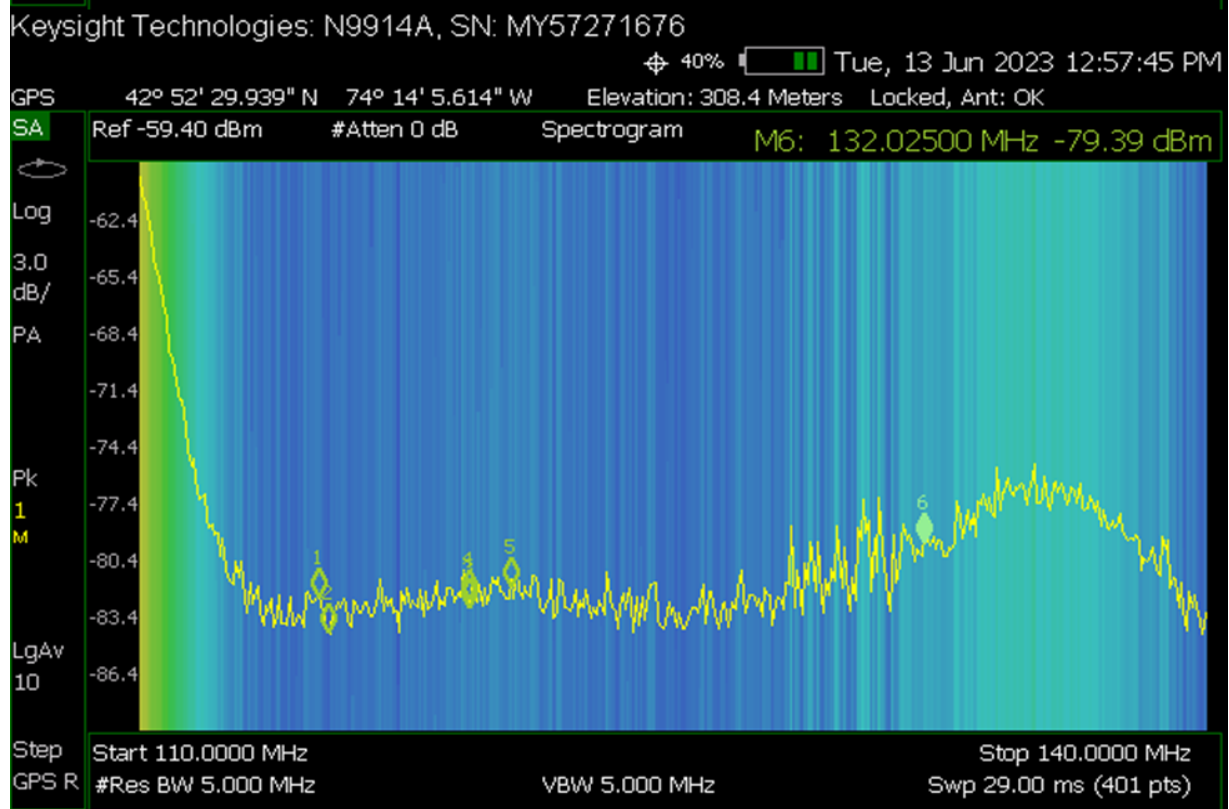
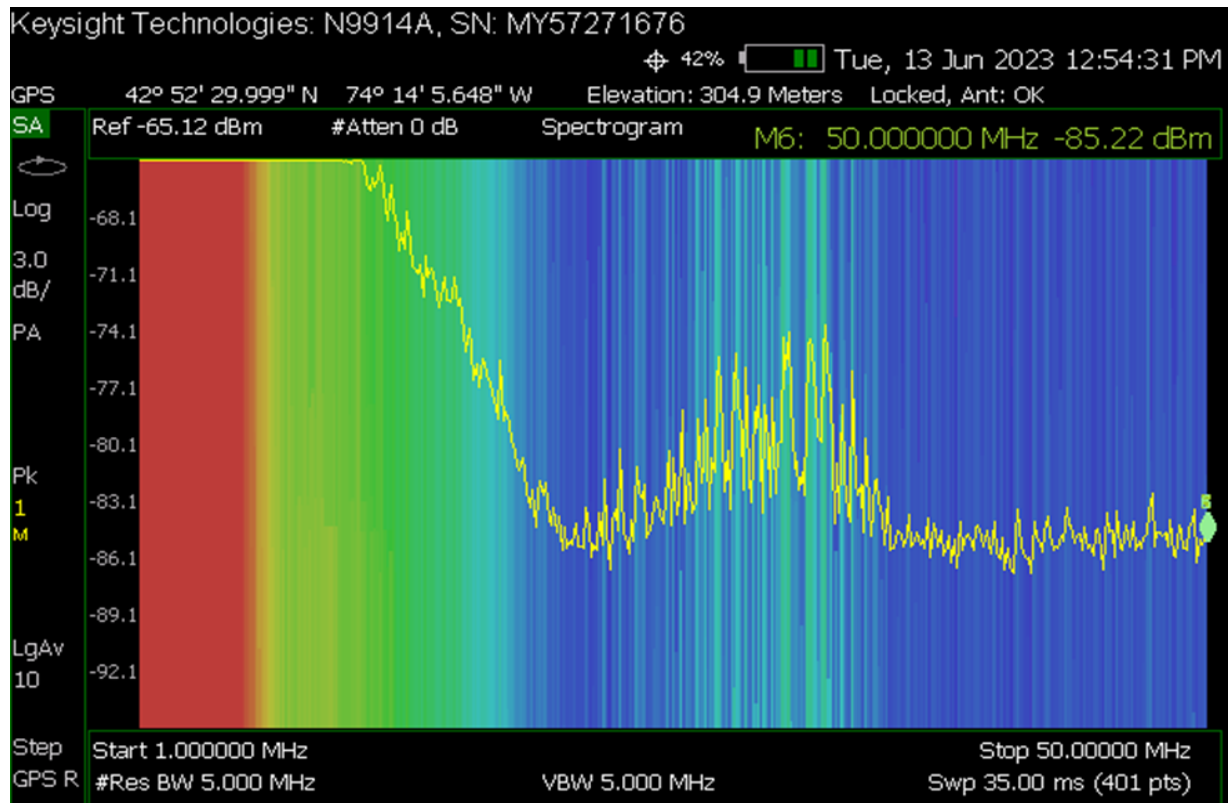

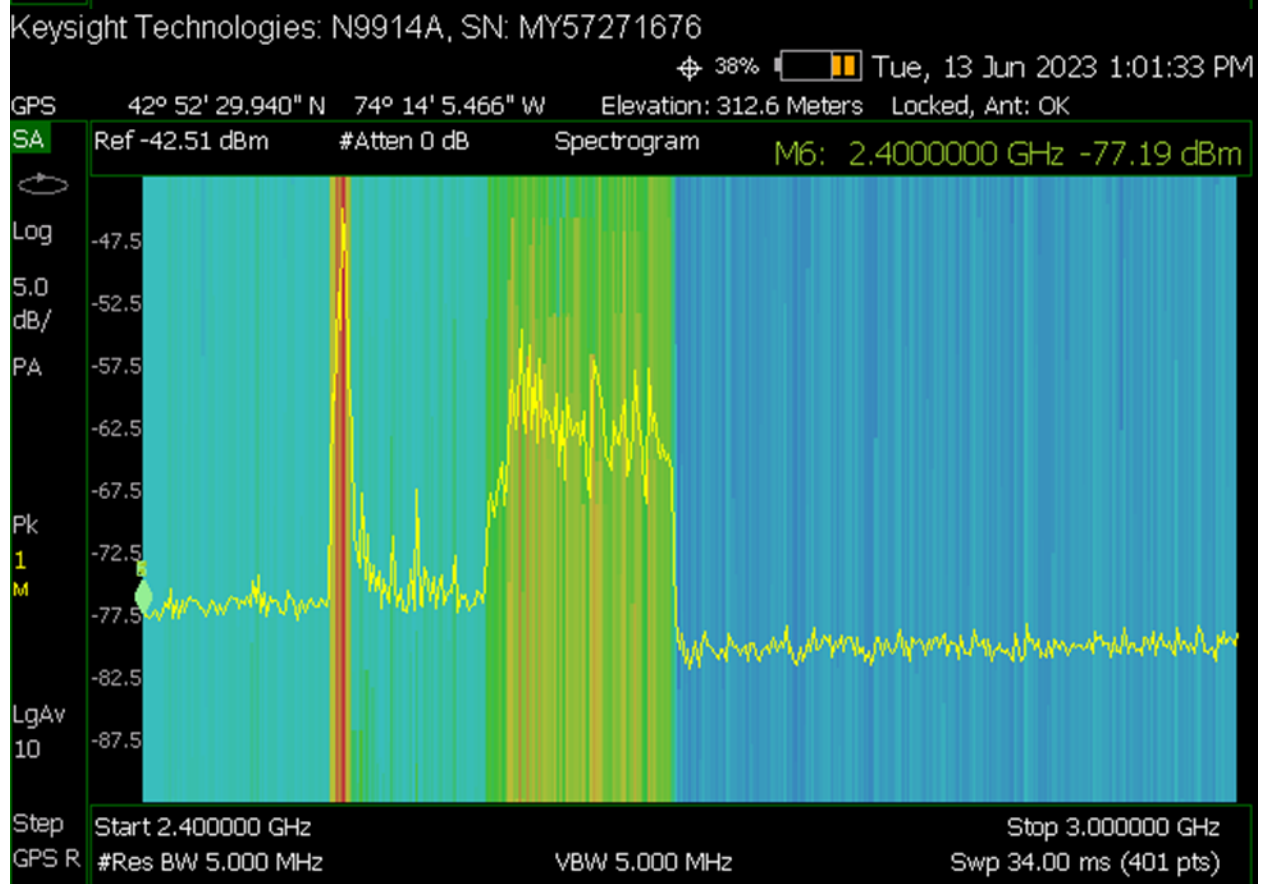
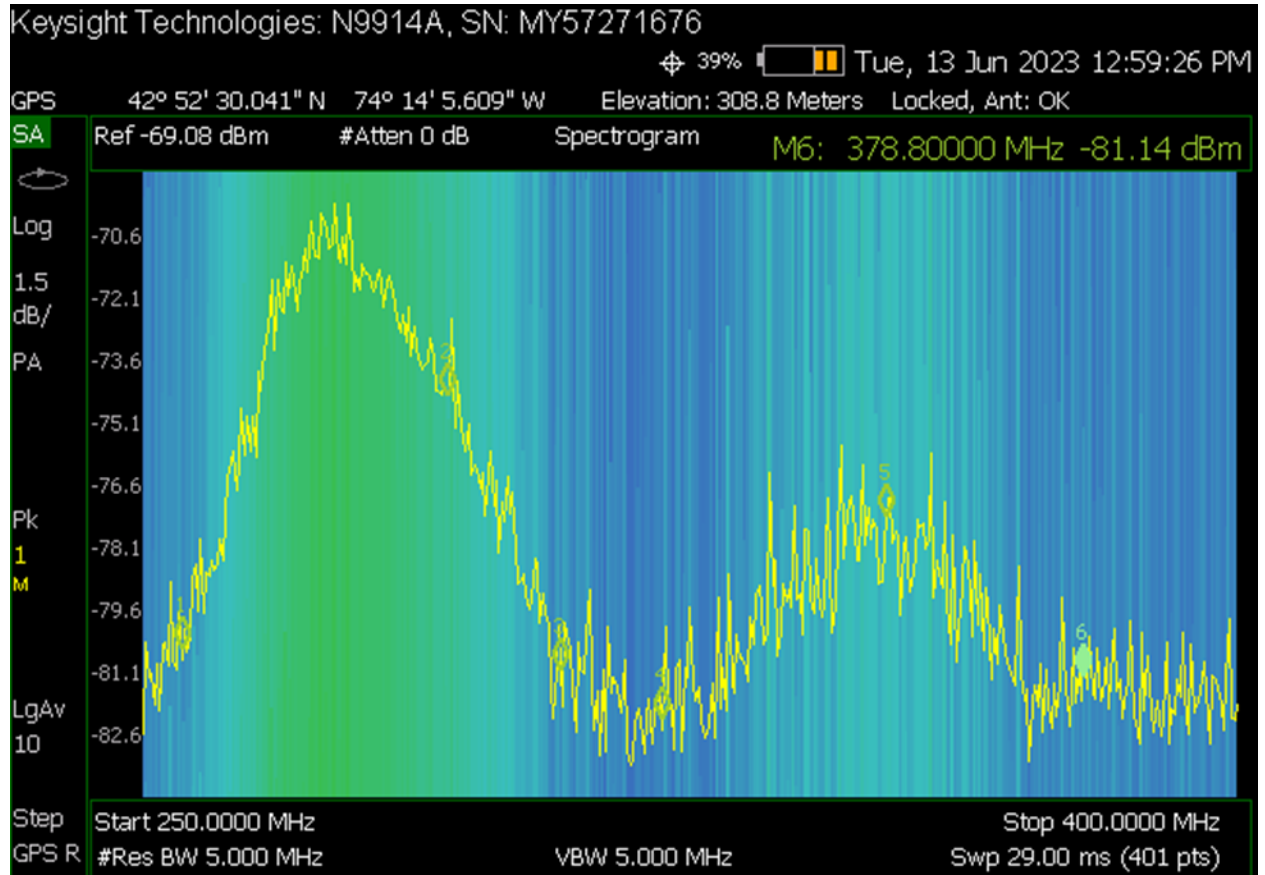

High Resolution Measurements

All data can be found here:

<https://drive.google.com/file/d/1AtUwjDilqPTZnSyI2rHh2TSZp8GdBYU5/view?usp=sharing>

Measurement Location 2

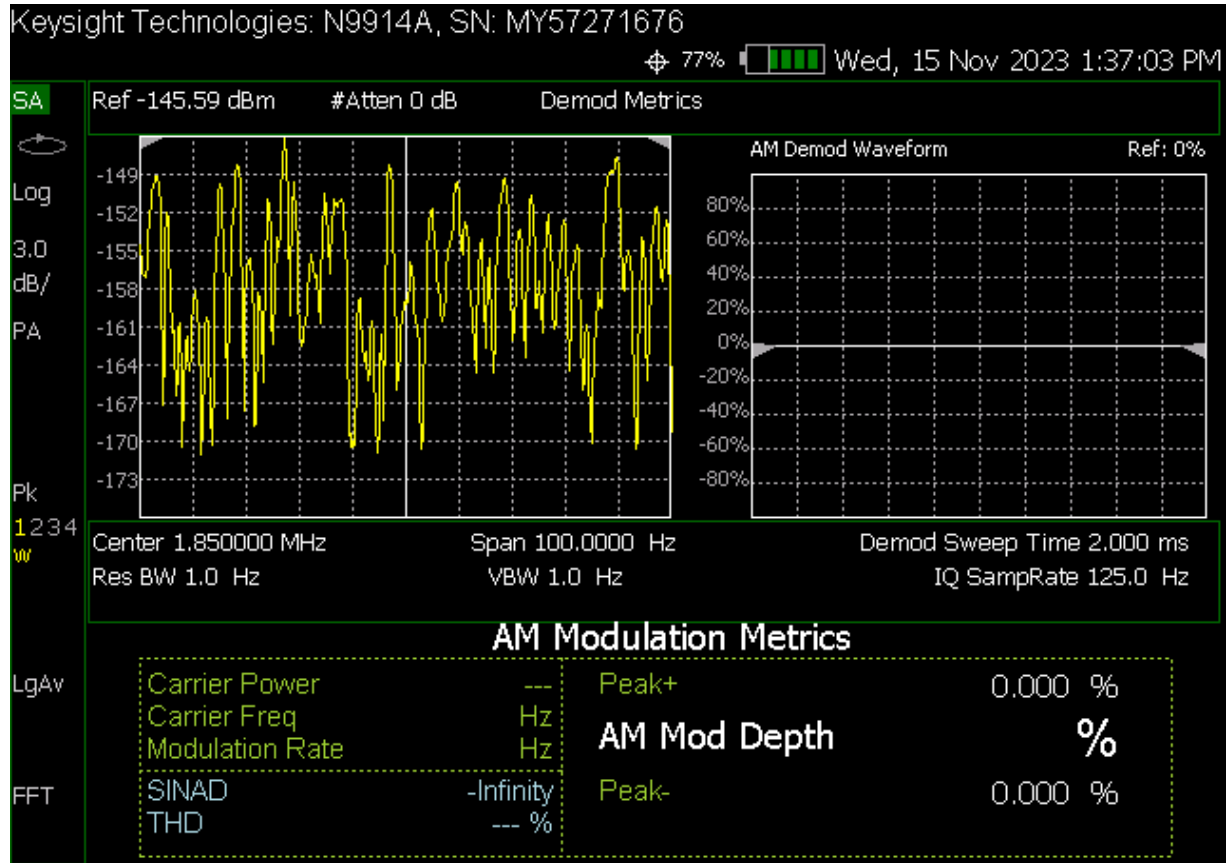

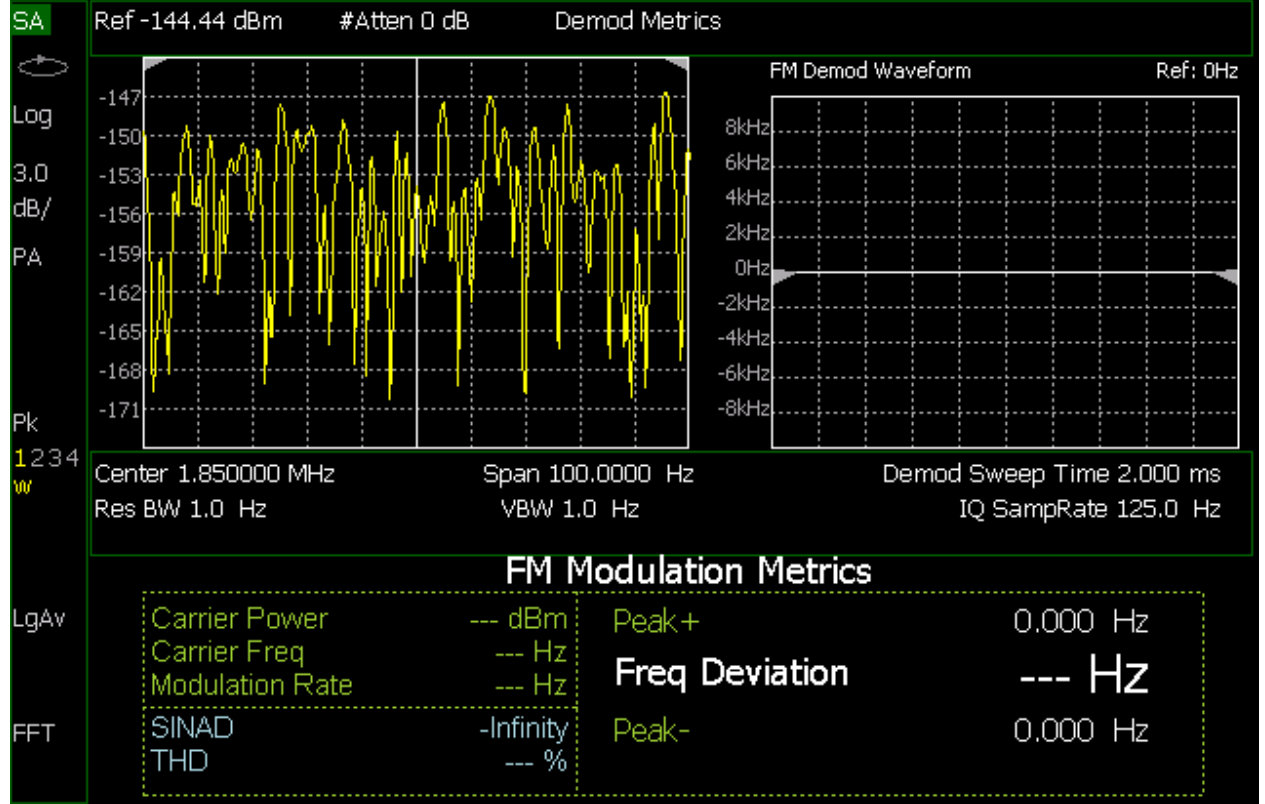

SA Ref -148.00 dBm #Atten 0 dB Demod Metrics

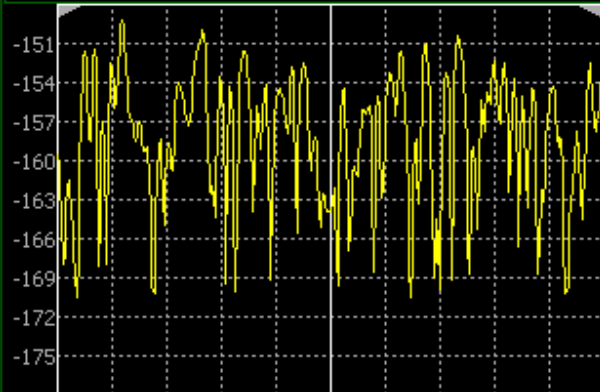
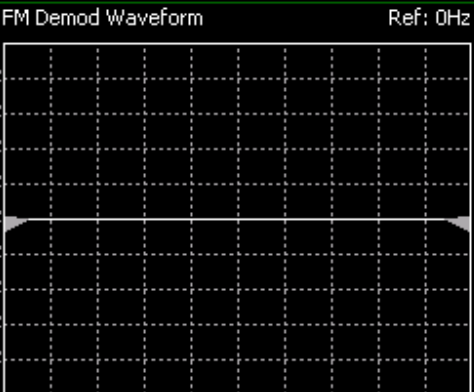



Center 3.850000 MHz Span 100.0000 Hz Demod Sweep Time 2.000 ms
 Res BW 1.0 Hz VBW 1.0 Hz IQ SampRate 125.0 Hz

FM Modulation Metrics

Carrier Power	--- dBm	Peak+	0.000 Hz
Carrier Freq	--- Hz	Freq Deviation	--- Hz
Modulation Rate	--- Hz	Peak-	0.000 Hz
SINAD	-Infinity		
THD	--- %		

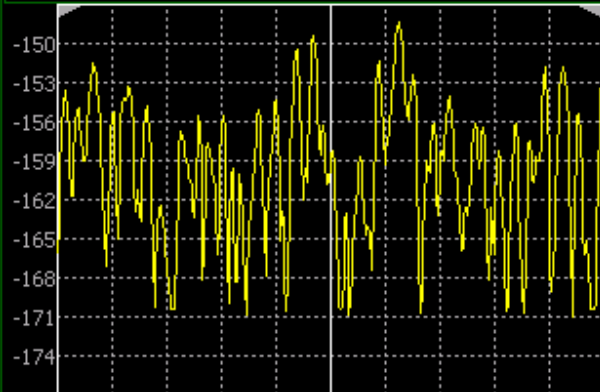
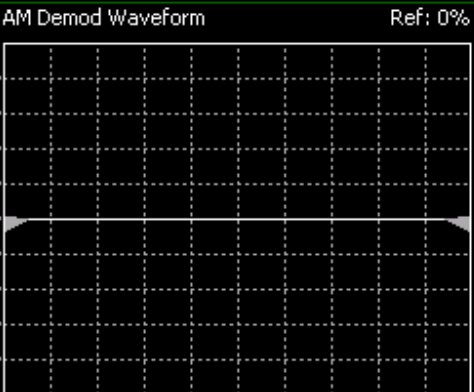
SA Ref -146.65 dBm #Atten 0 dB Demod Metrics

Center 3.850000 MHz Span 100.0000 Hz Demod Sweep Time 2.000 ms
 Res BW 1.0 Hz VBW 1.0 Hz IQ SampRate 125.0 Hz

AM Modulation Metrics

Carrier Power	--	Peak+	0.000 %
Carrier Freq	Hz	AM Mod Depth	%
Modulation Rate	Hz		
SINAD	-Infinity	Peak-	0.000 %
THD	-- %		

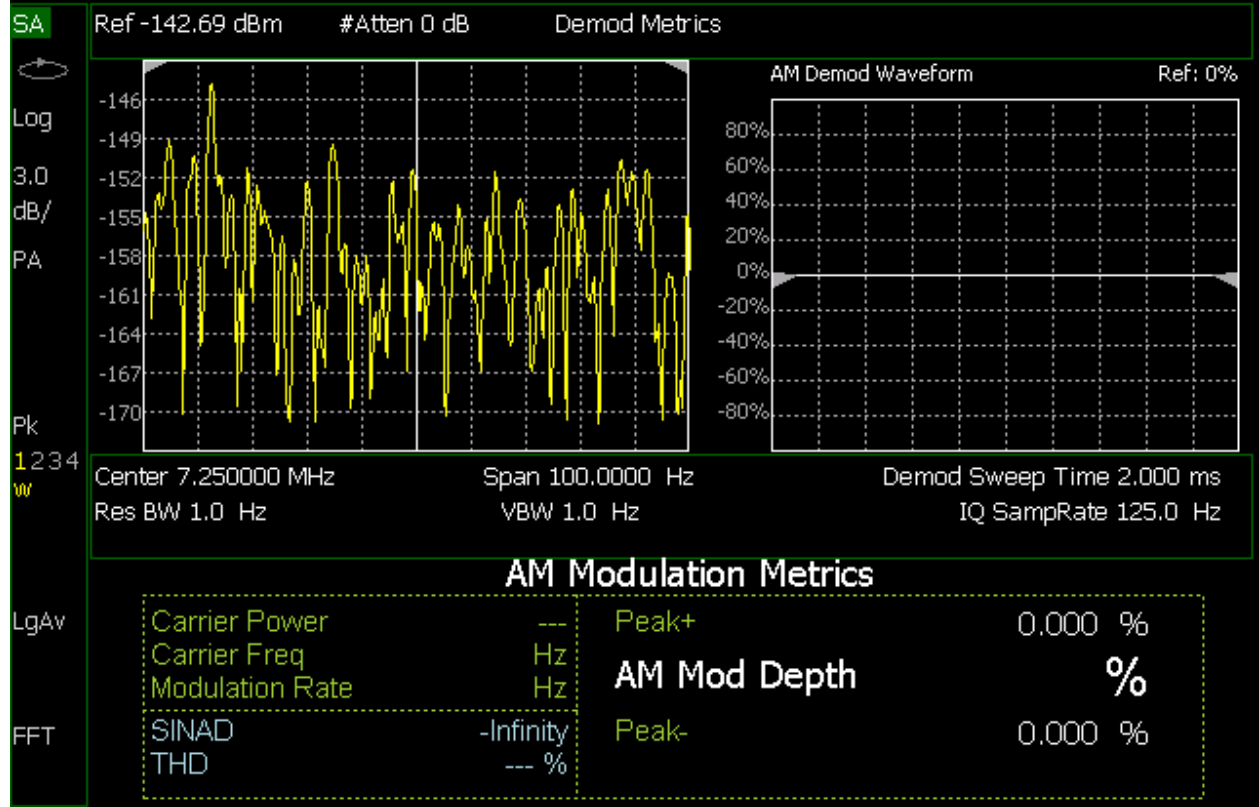

SA Ref -137.14 dBm #Atten 0 dB Demod Metrics

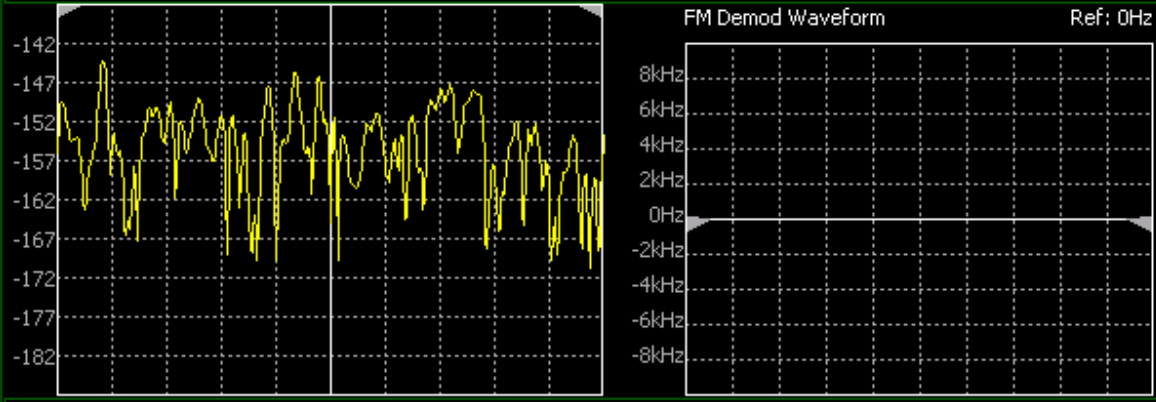

Center 7.250000 MHz Span 100.0000 Hz Demod Sweep Time 2.000 ms
 Res BW 1.0 Hz VBW 1.0 Hz IQ SampRate 125.0 Hz

FM Modulation Metrics

Carrier Power	--- dBm	Peak+	0.000 Hz
Carrier Freq	--- Hz	Freq Deviation	--- Hz
Modulation Rate	--- Hz	Peak-	0.000 Hz
SINAD	-Infinity		
THD	--- %		

LgAv
FFT

SA Ref -141.76 dBm #Atten 0 dB Demod Metrics

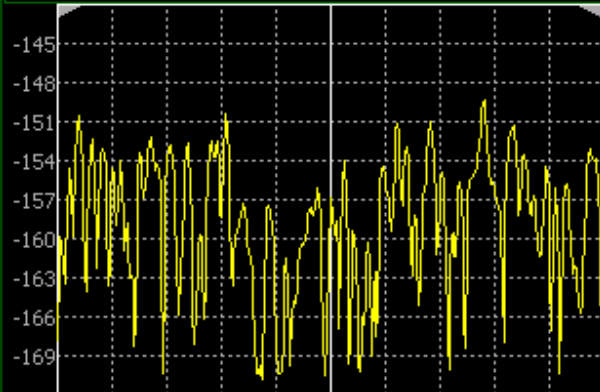

Center 14.25000 MHz Span 100.0000 Hz
Res BW 1.0 Hz VBW 1.0 Hz

FM Demod Waveform Ref: 0Hz

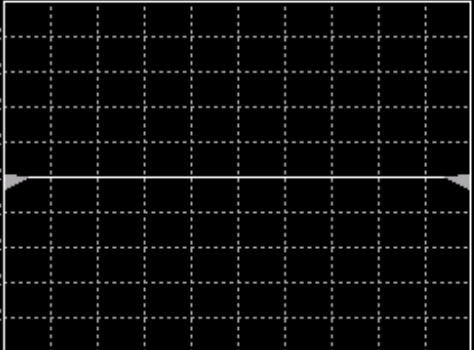

Demod Sweep Time 2.000 ms
IQ SampRate 125.0 Hz

FM Modulation Metrics

Carrier Power	--- dBm	Peak+	0.000 Hz
Carrier Freq	--- Hz	Freq Deviation	--- Hz
Modulation Rate	--- Hz	Peak-	0.000 Hz
SINAD	-Infinity		
THD	--- %		

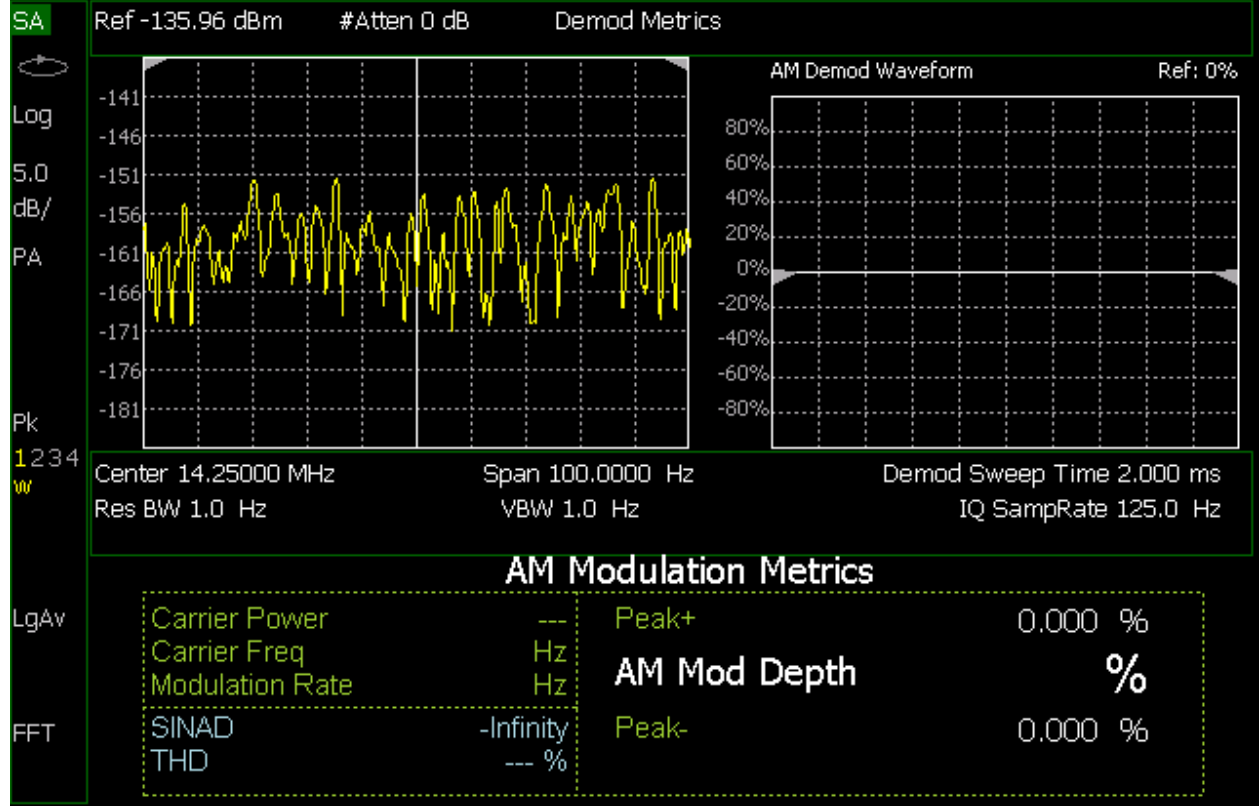

SA Ref -152.66 dBm #Atten 0 dB Demod Metrics

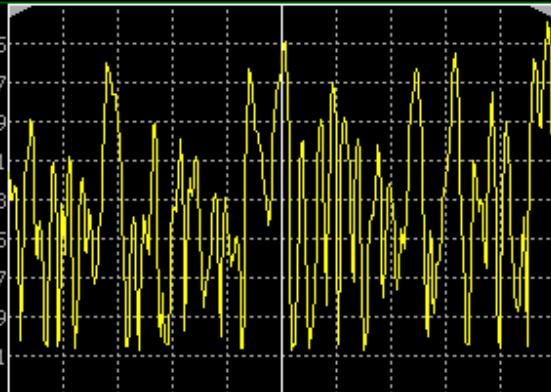

AM Demod Waveform Ref: 0%

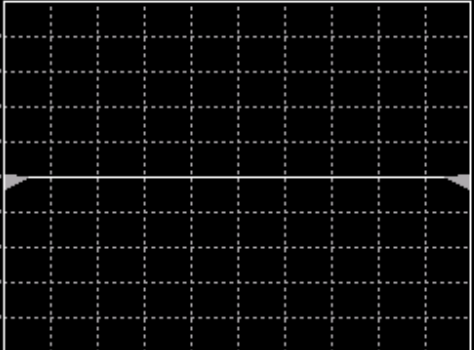

Center 18.25000 MHz Span 100.0000 Hz Demod Sweep Time 2.000 ms
 Res BW 1.0 Hz VBW 1.0 Hz IQ SampRate 125.0 Hz

AM Modulation Metrics

Carrier Power	---	Peak+	0.000 %
Carrier Freq	Hz	AM Mod Depth	%
Modulation Rate	Hz		
SINAD	-Infinity	Peak-	0.000 %
THD	---		

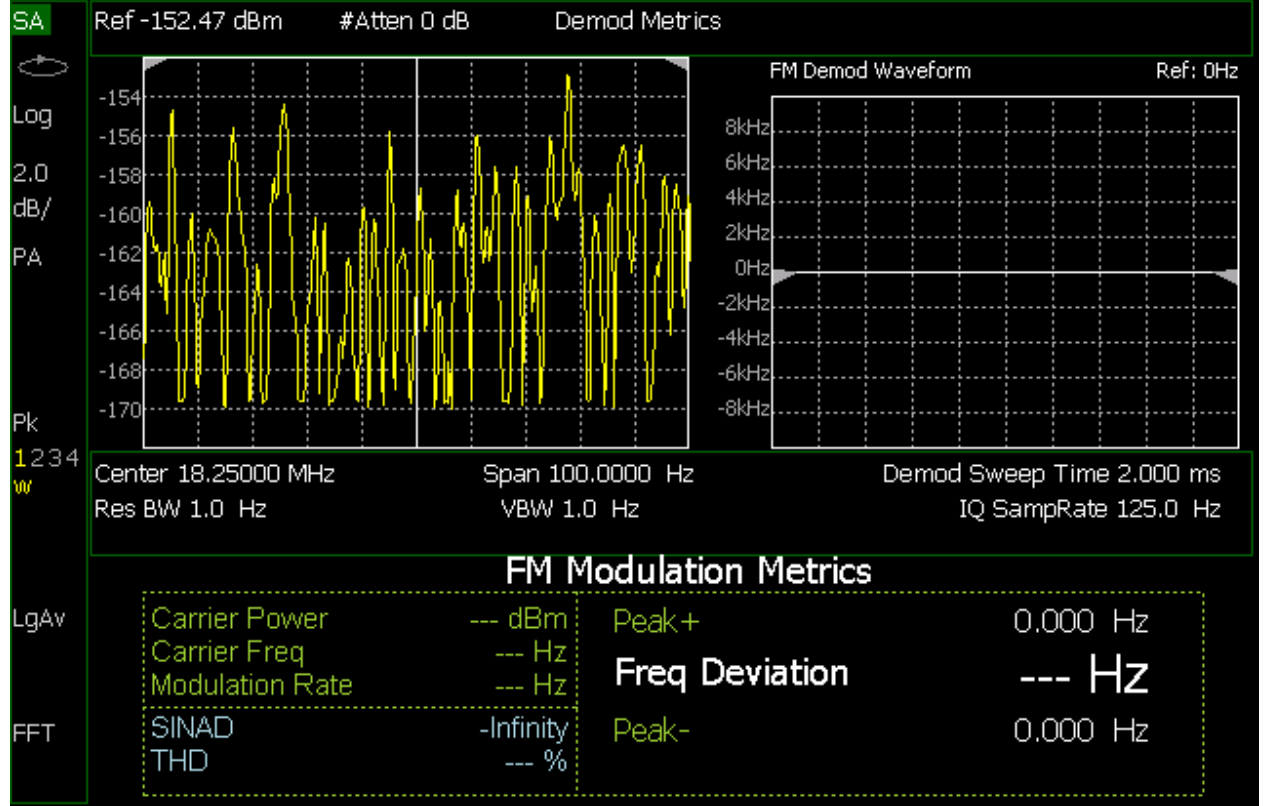

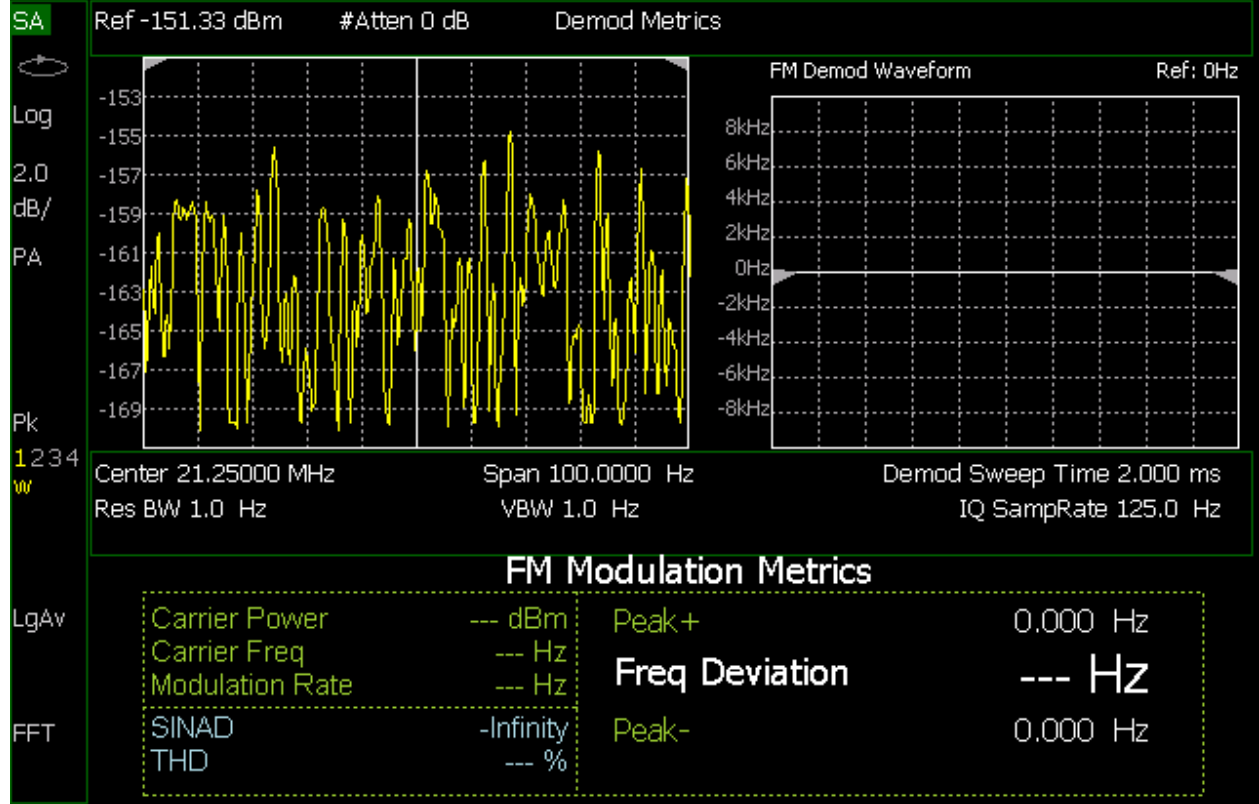

SA Ref -151.17 dBm #Atten 0 dB Demod Metrics

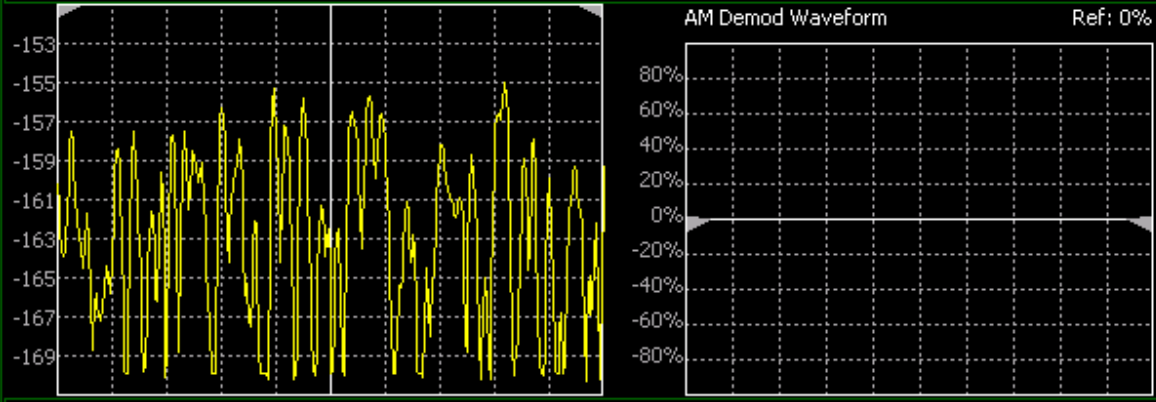

AM Demod Waveform Ref: 0%

Center 21.2500 MHz Span 100.0000 Hz Demod Sweep Time 2.000 ms
 Res BW 1.0 Hz VBW 1.0 Hz IQ SampRate 125.0 Hz

AM Modulation Metrics

Carrier Power	--	Peak+	0.000 %
Carrier Freq	Hz	AM Mod Depth	%
Modulation Rate	Hz		
SINAD	-Infinity	Peak-	0.000 %
THD	-- %		

SA Ref -151.15 dBm #Atten 0 dB Demod Metrics

Log
2.0
dB/
PA
Pk
1 2 3 4
w



Center 28.50000 MHz Span 100.0000 Hz Demod Sweep Time 2.000 ms
Res BW 1.0 Hz VBW 1.0 Hz IQ SampRate 125.0 Hz

AM Demod Waveform Ref: 0%

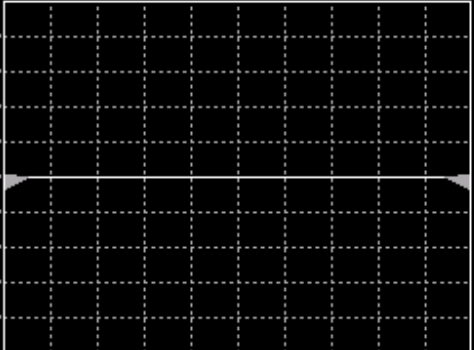

AM Modulation Metrics

Carrier Power	--	Peak+	0.000 %
Carrier Freq	Hz	AM Mod Depth	%
Modulation Rate	Hz		
SINAD	-Infinity	Peak-	0.000 %
THD	-- %		

LgAv
FFT

SA
Ref -152.85 dBm #Atten 0 dB Demod Metrics

FM Demod Waveform Ref: 0Hz

Center 28.50000 MHz
Res BW 1.0 Hz

Span 100.0000 Hz
VBW 1.0 Hz

Demod Sweep Time 2.000 ms
IQ SampRate 125.0 Hz

FM Modulation Metrics

Carrier Power	--- dBm	Peak+	0.000 Hz
Carrier Freq	--- Hz	Freq Deviation	--- Hz
Modulation Rate	--- Hz	Peak-	0.000 Hz
SINAD	-Infinity		
THD	--- %		

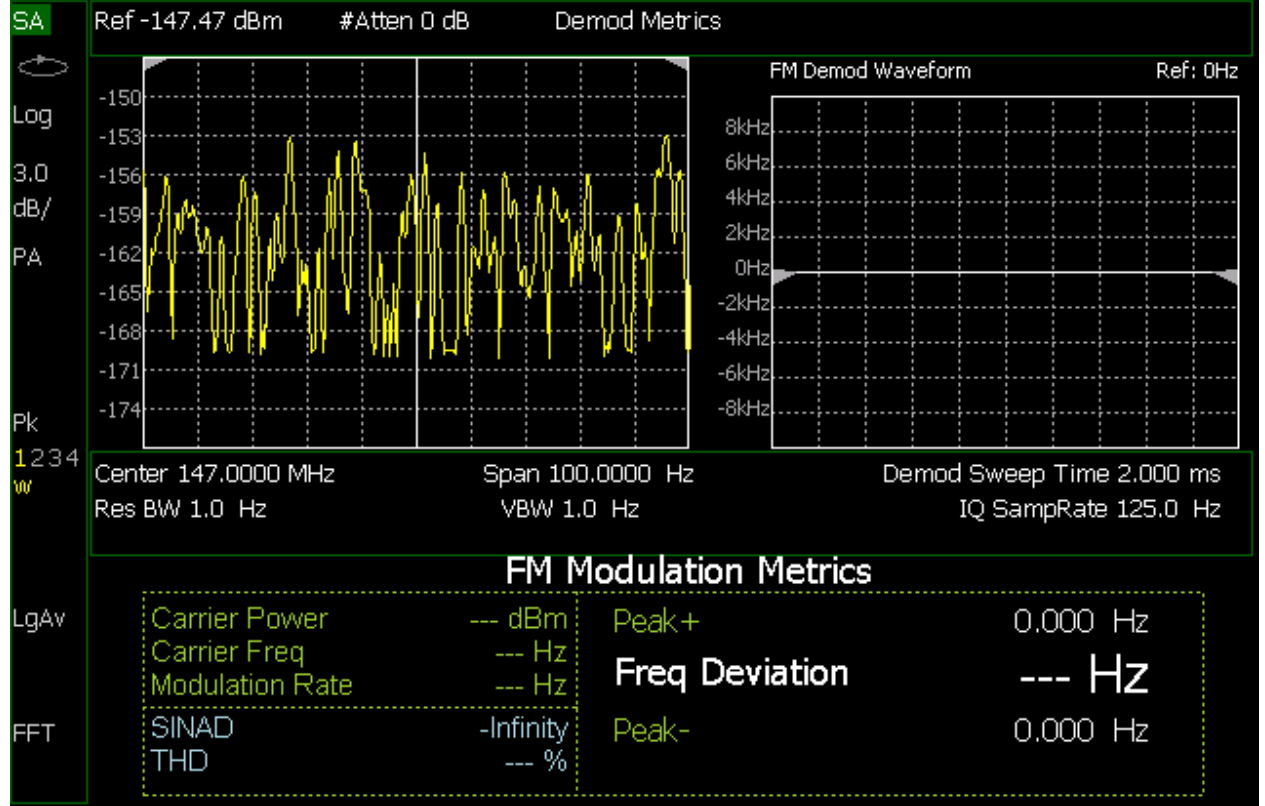

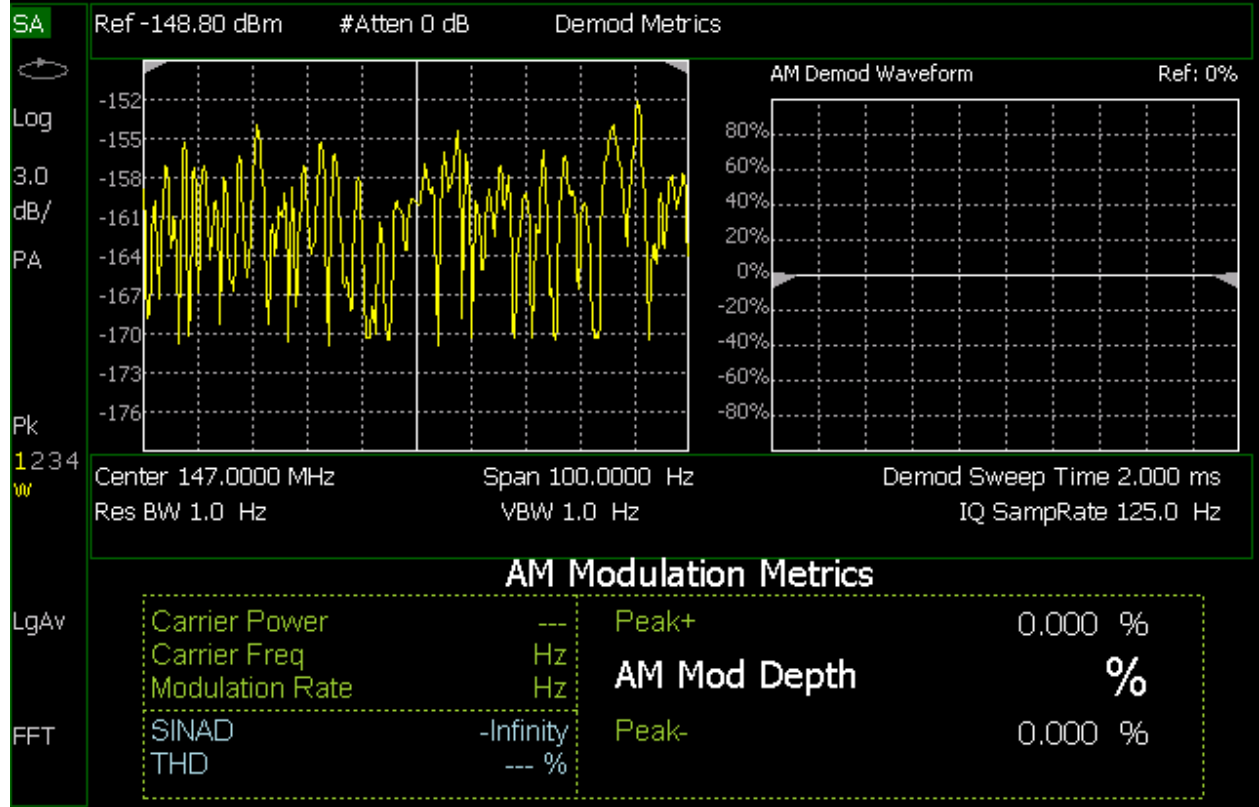

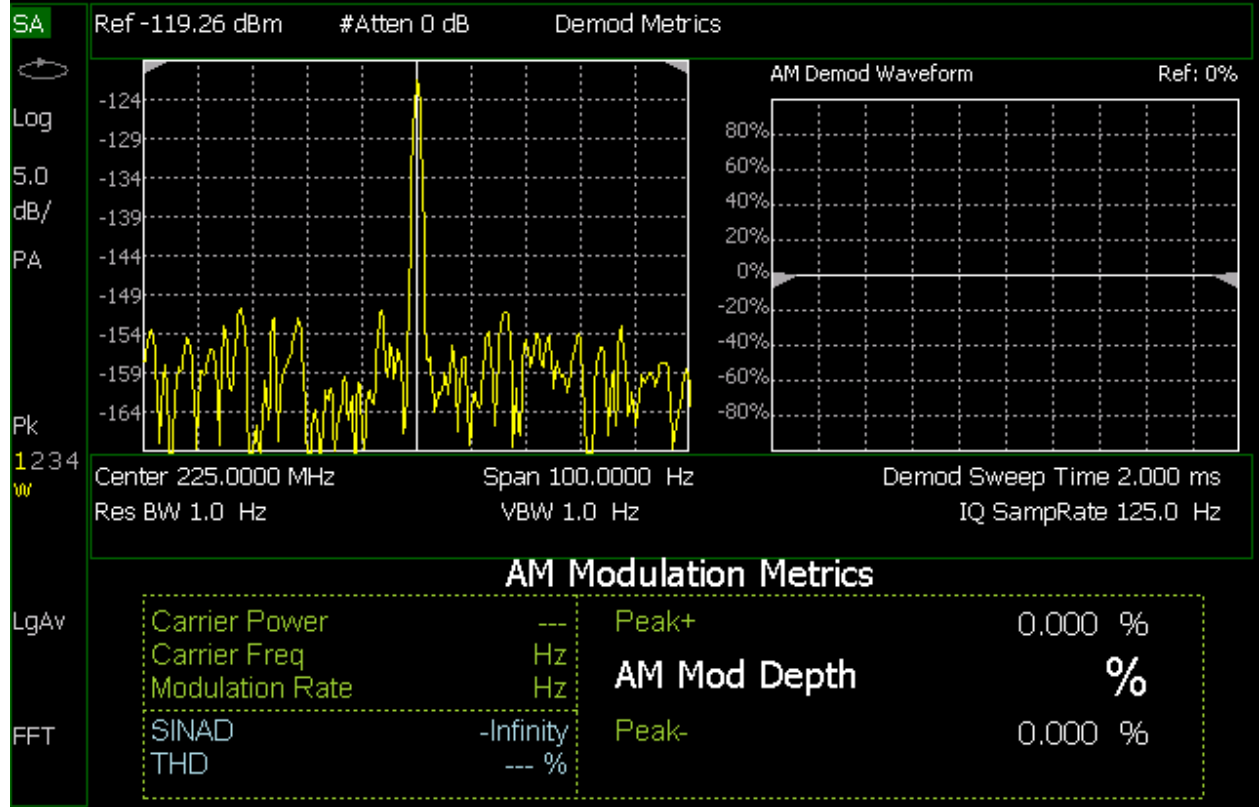

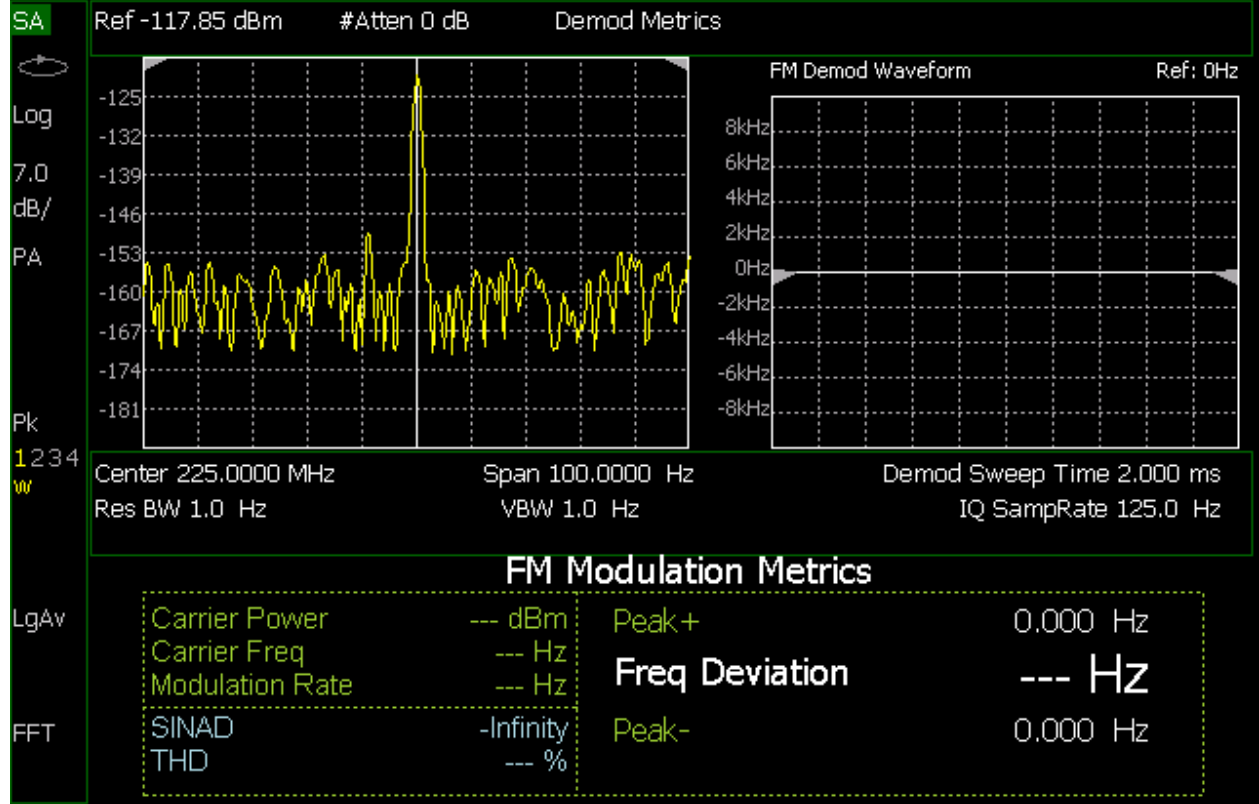

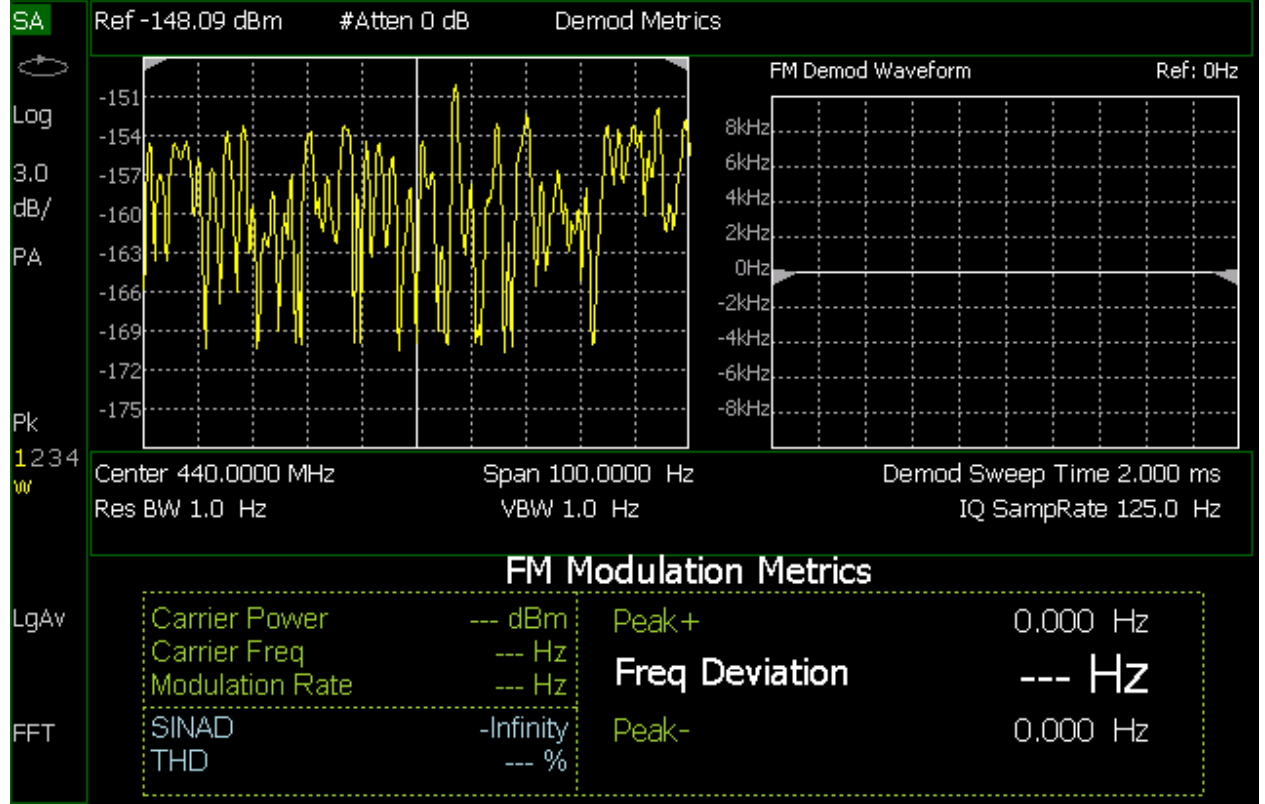

SA Ref -146.58 dBm #Atten 0 dB Demod Metrics



AM Demod Waveform Ref: 0%

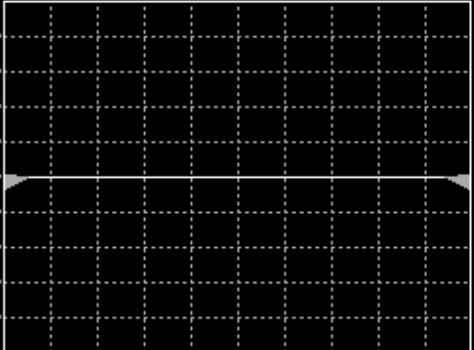

Center 440.0000 MHz Span 100.0000 Hz Demod Sweep Time 2.000 ms
 Res BW 1.0 Hz VBW 1.0 Hz IQ SampRate 125.0 Hz

AM Modulation Metrics

Carrier Power	---	Peak+	0.000 %
Carrier Freq	Hz	AM Mod Depth	%
Modulation Rate	Hz		
SINAD	-Infinity	Peak-	0.000 %
THD	---		

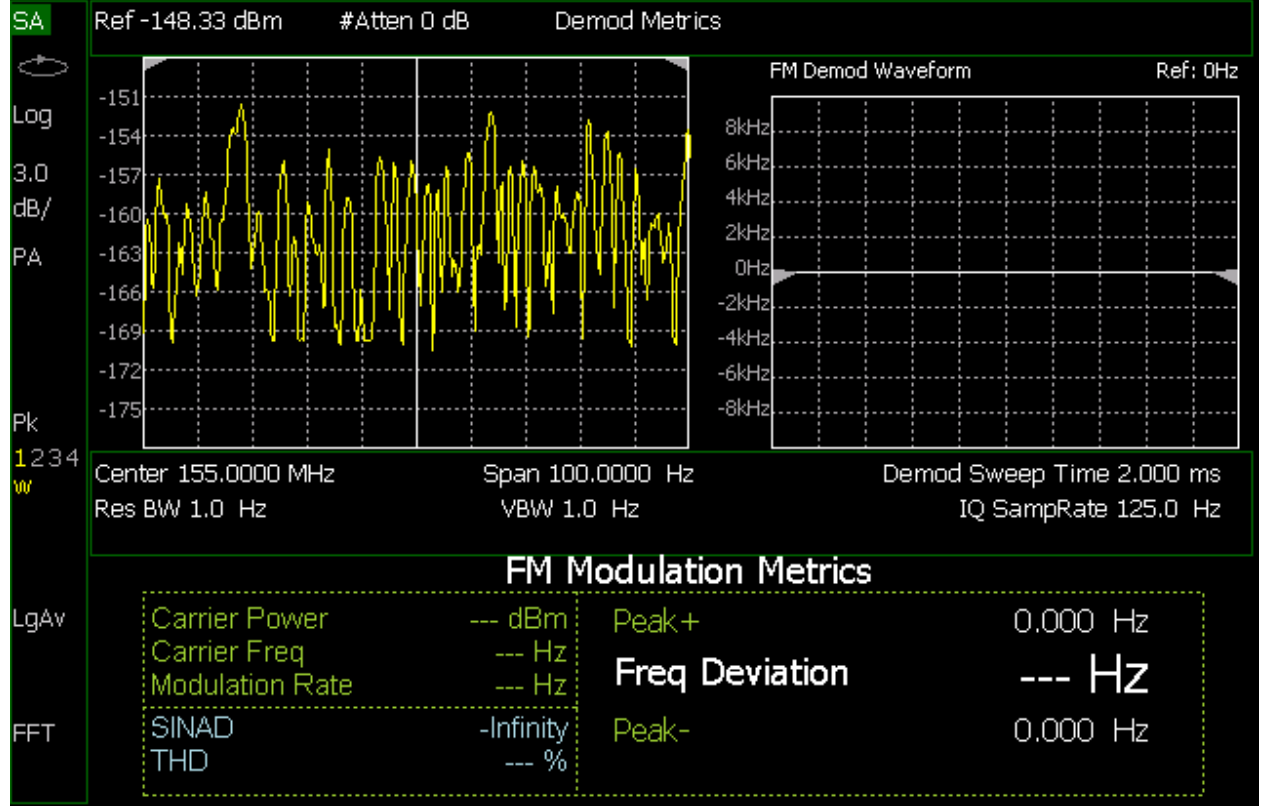

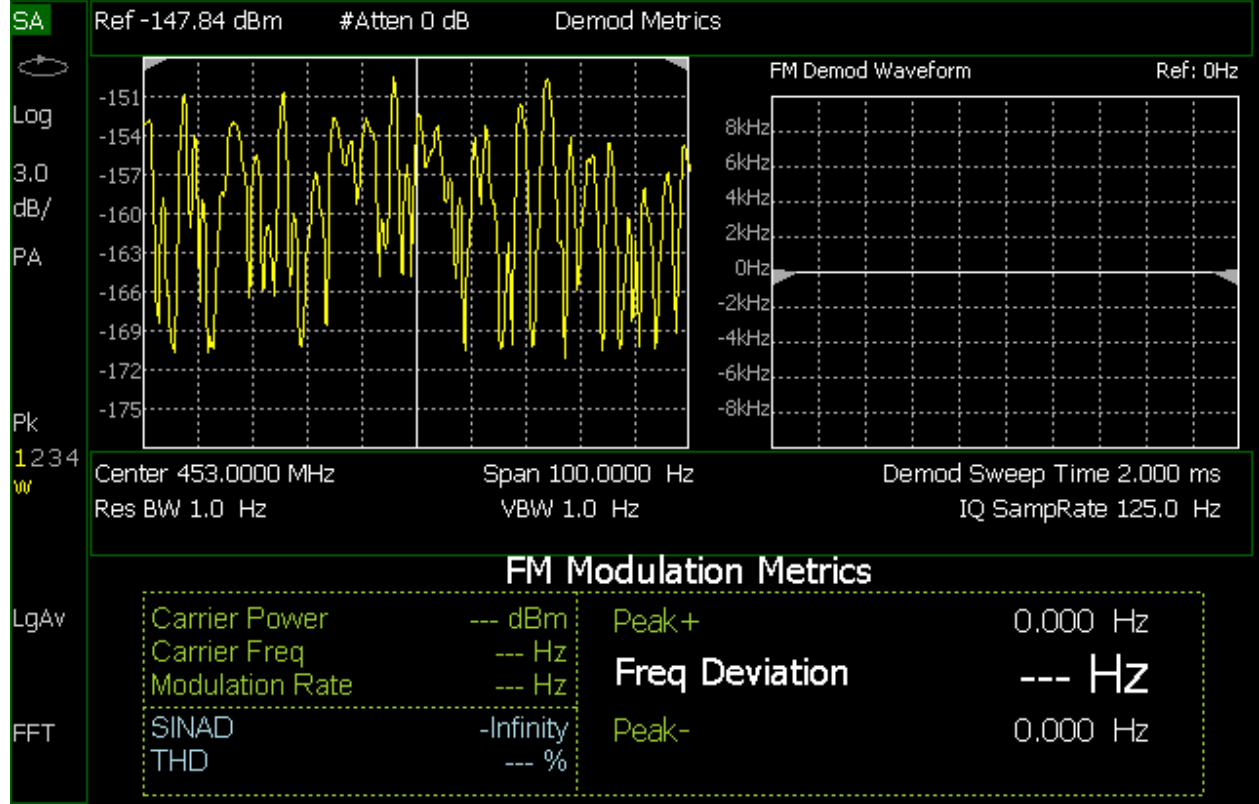

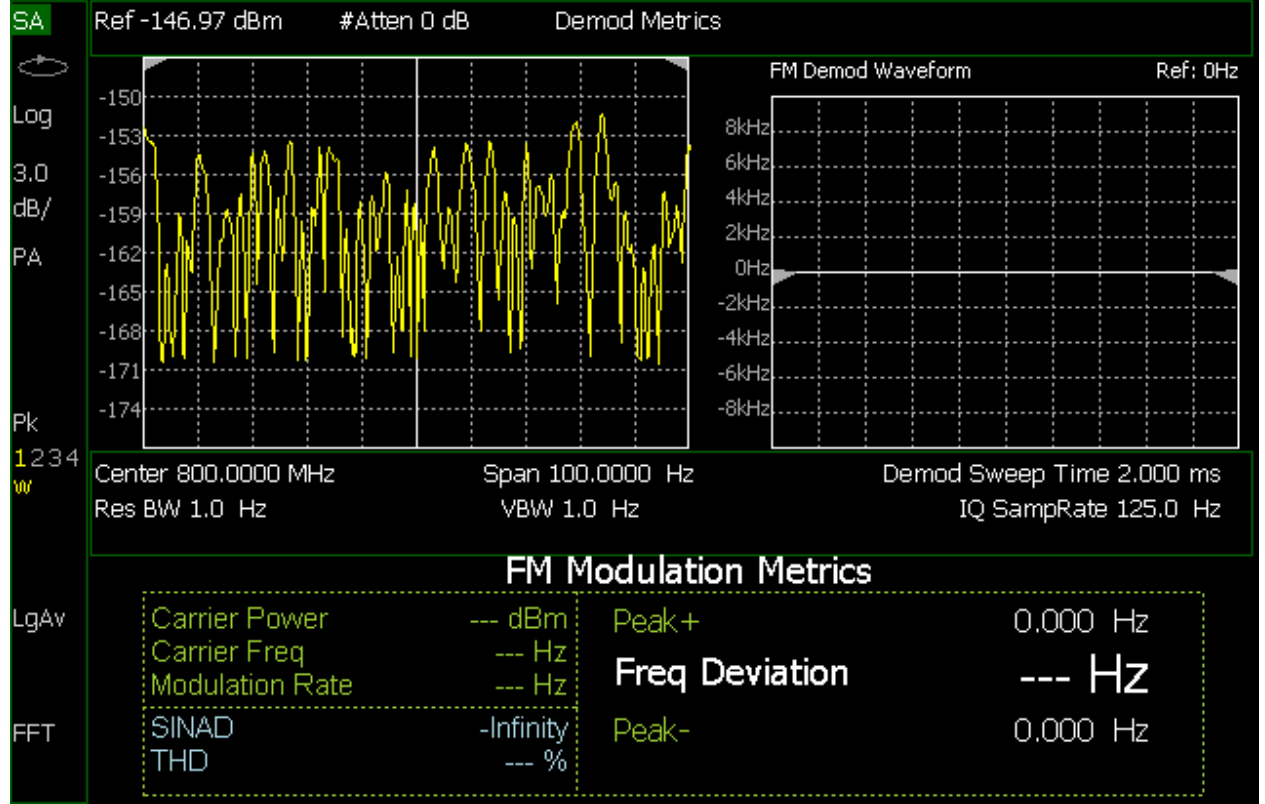

Measurement Location 13

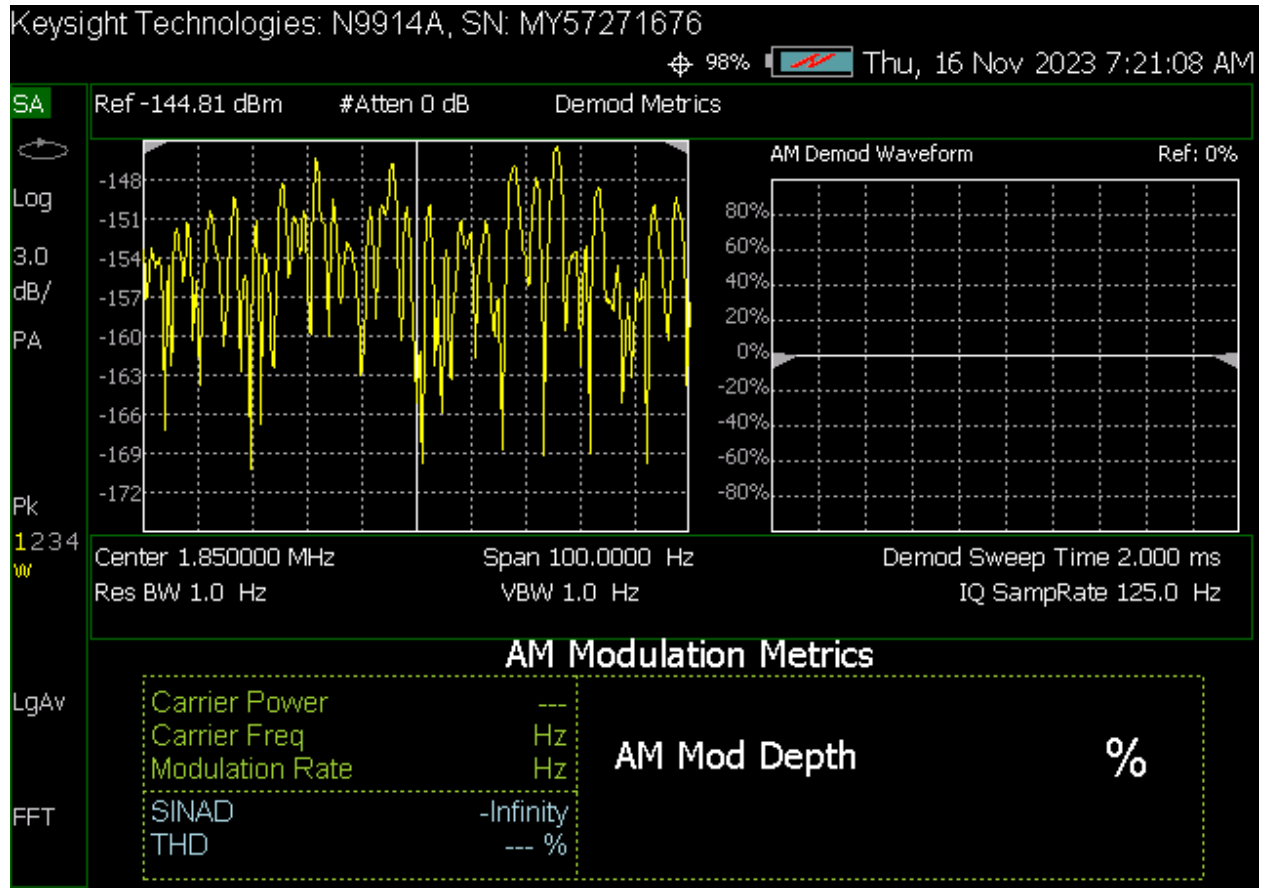

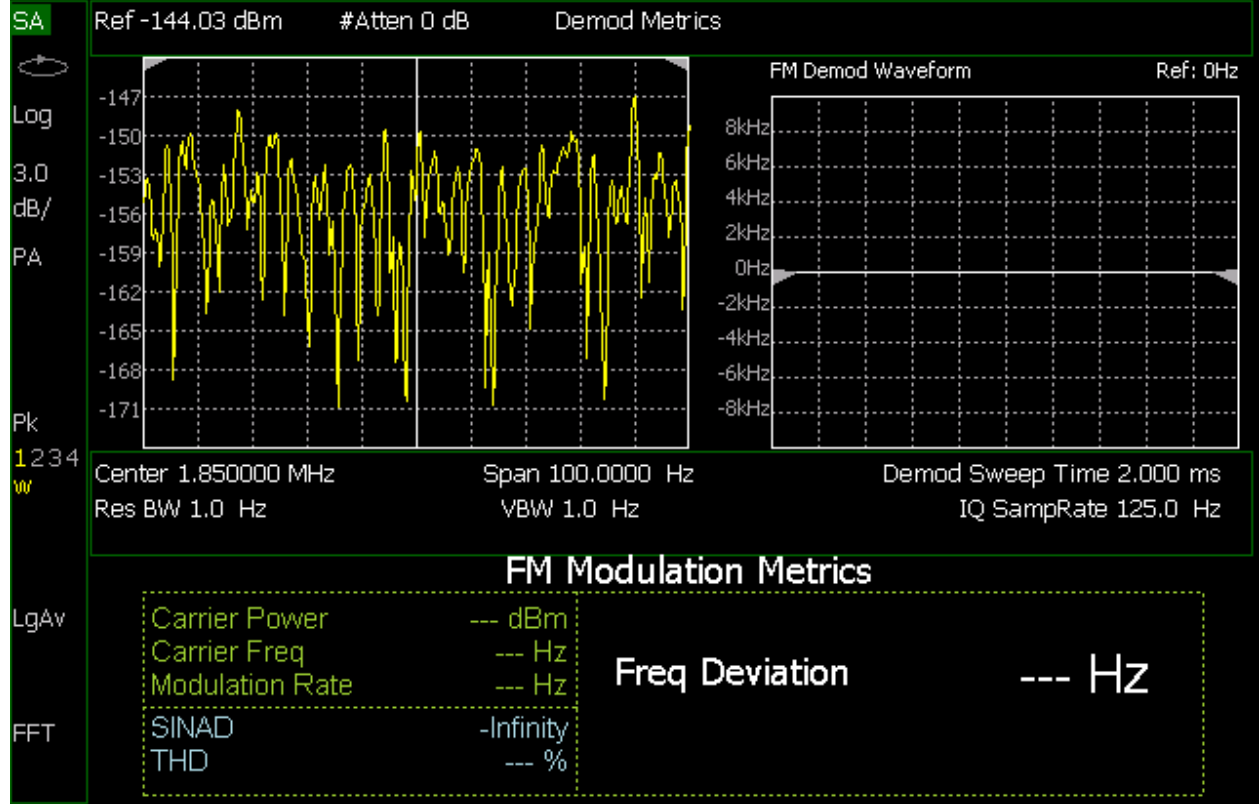

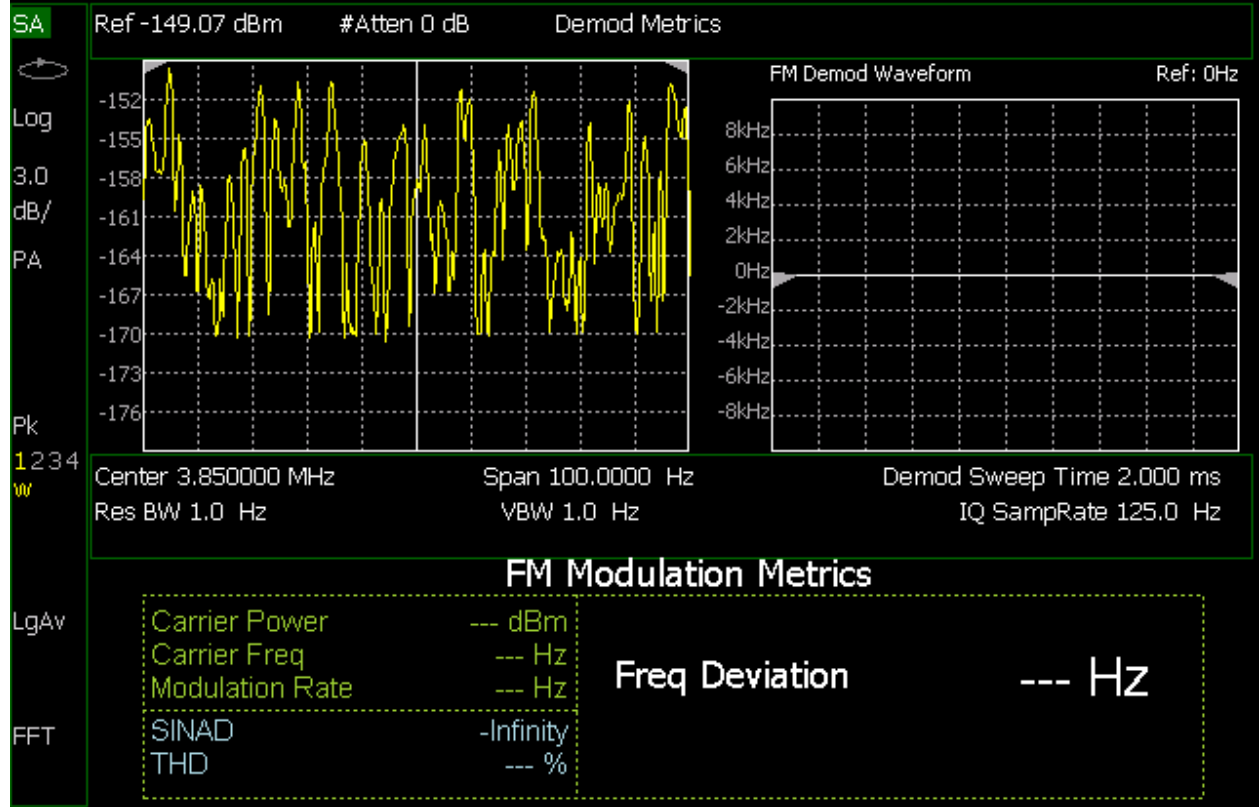

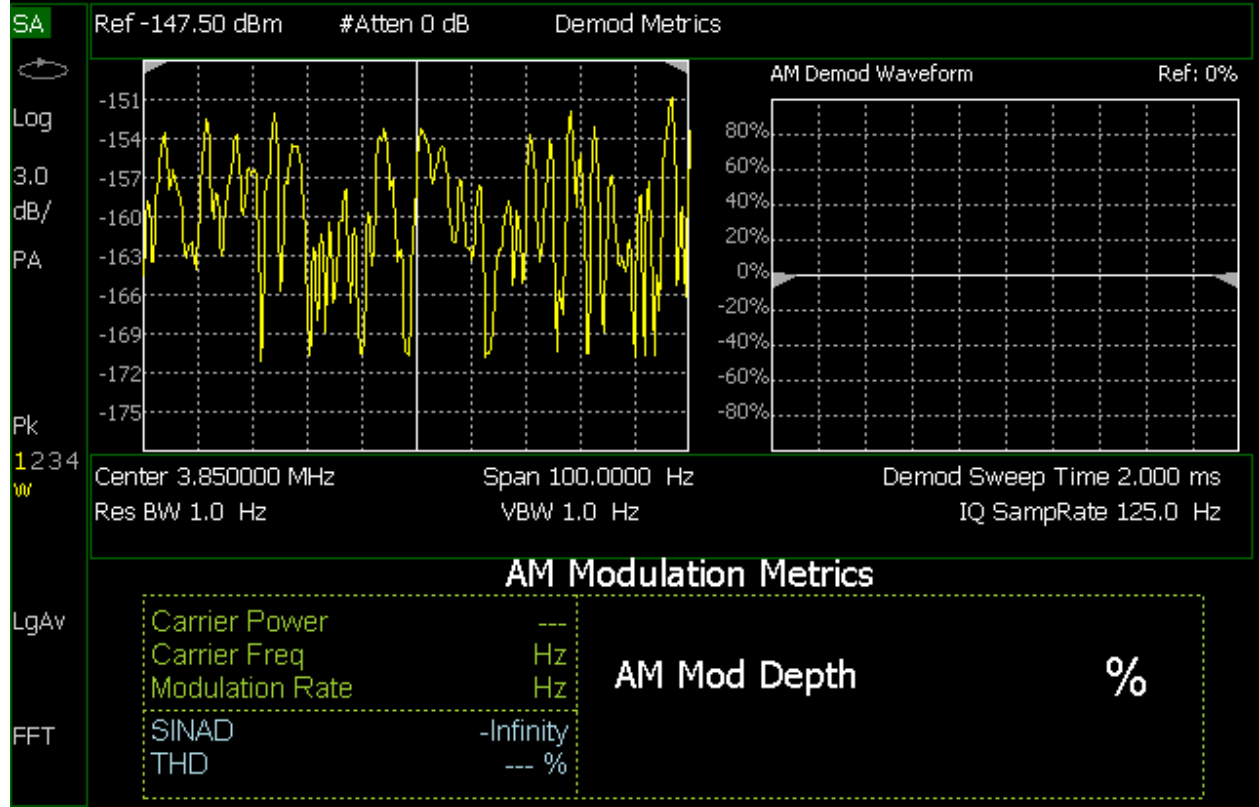

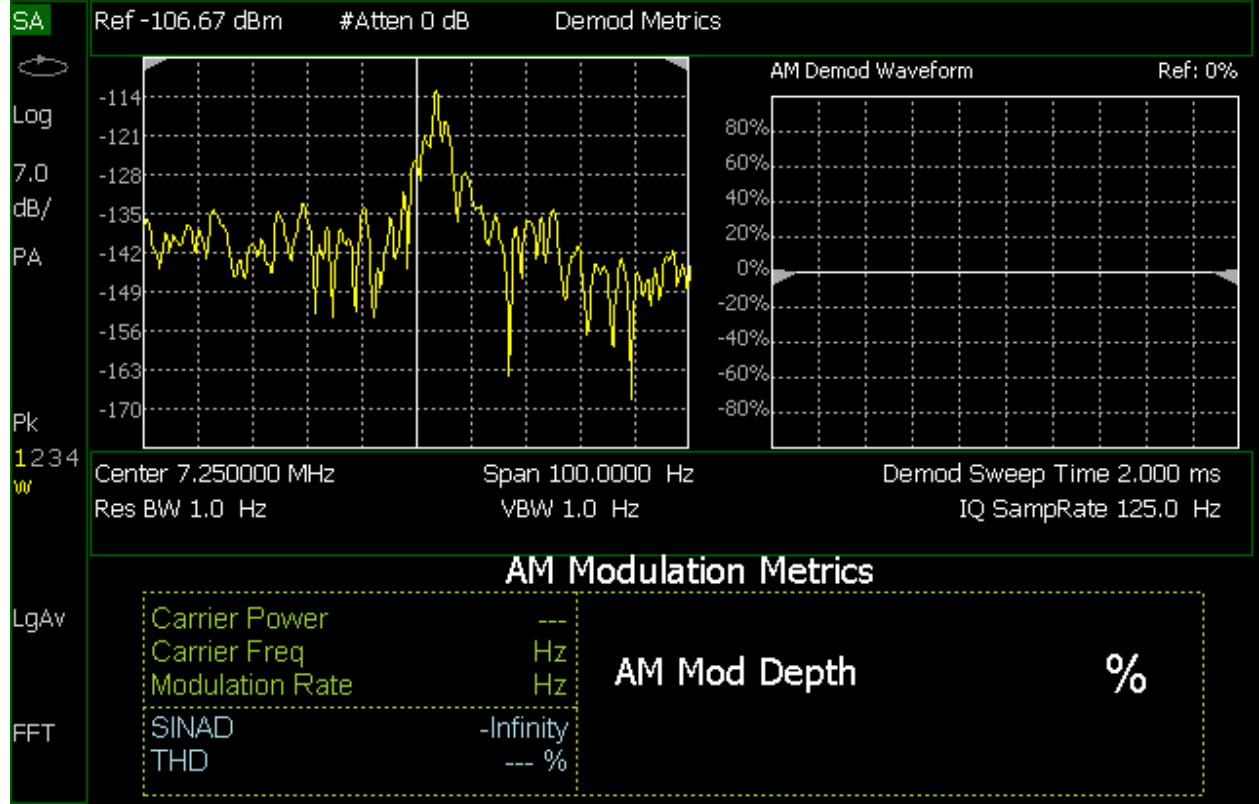

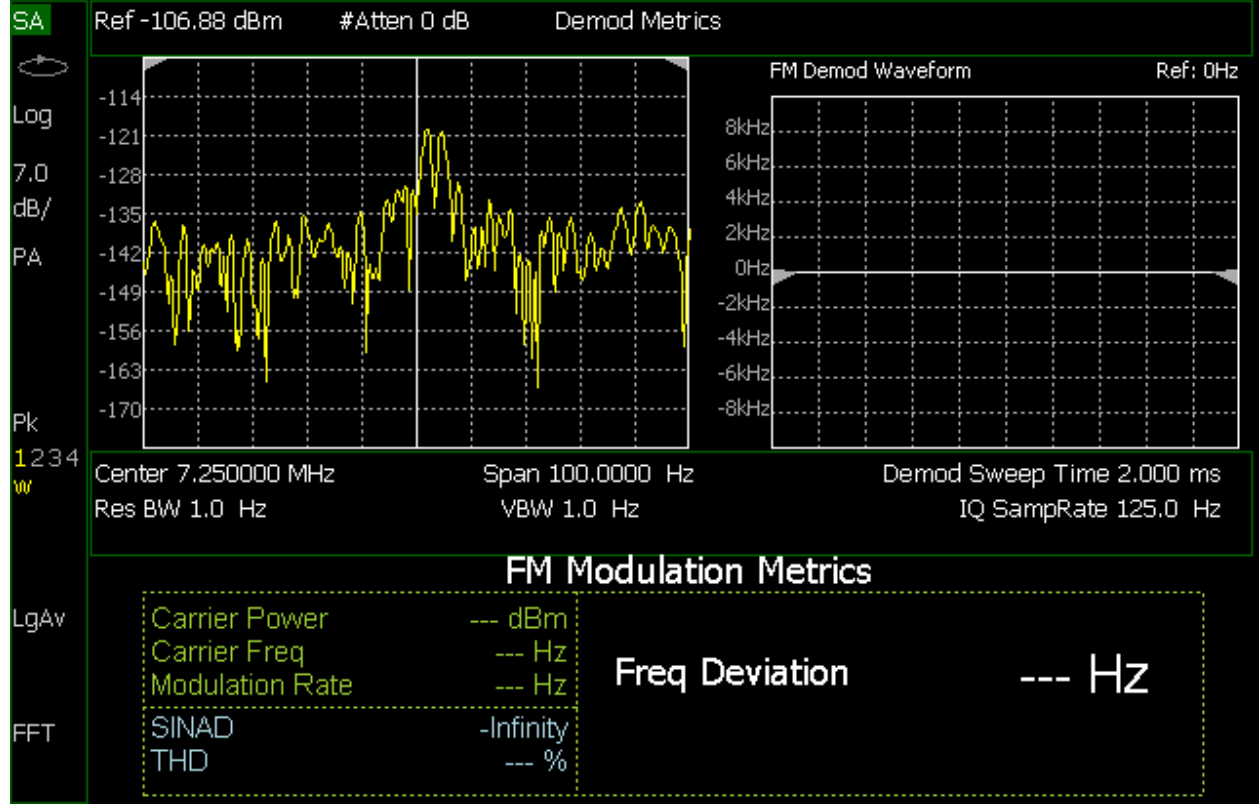

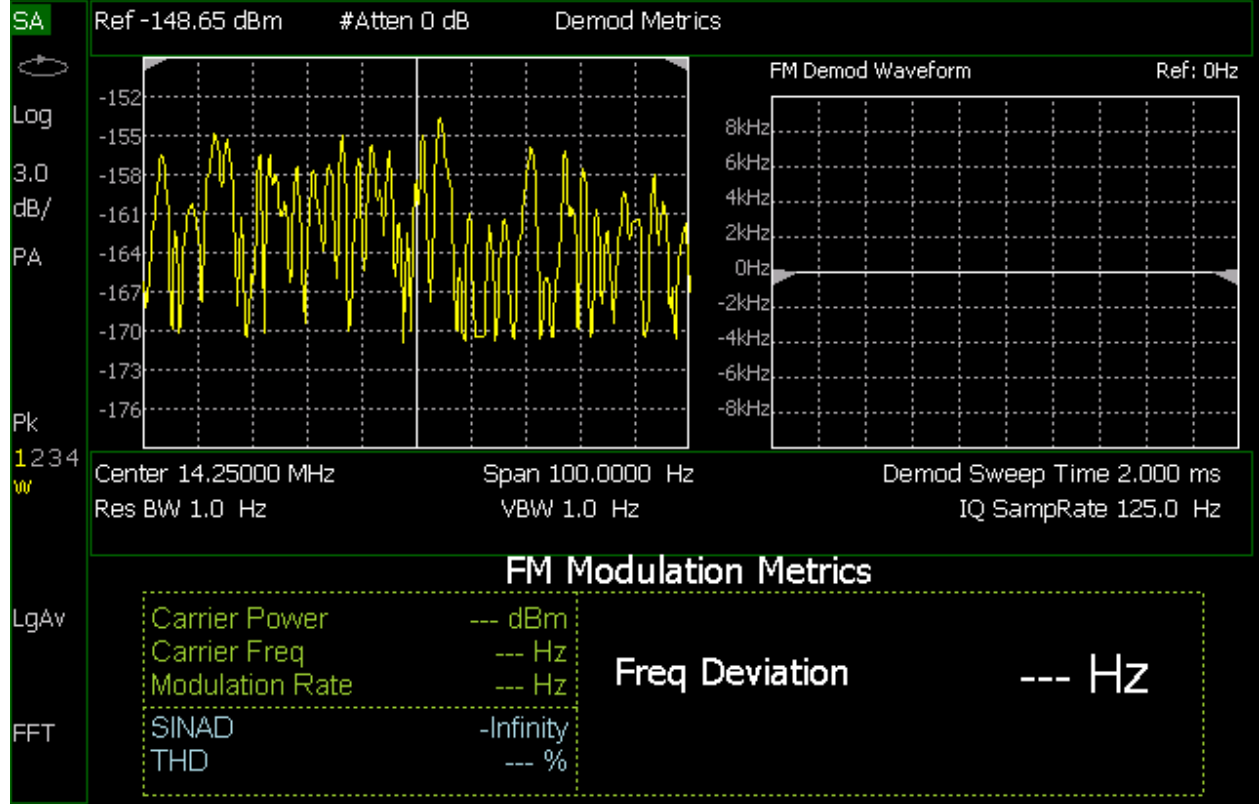

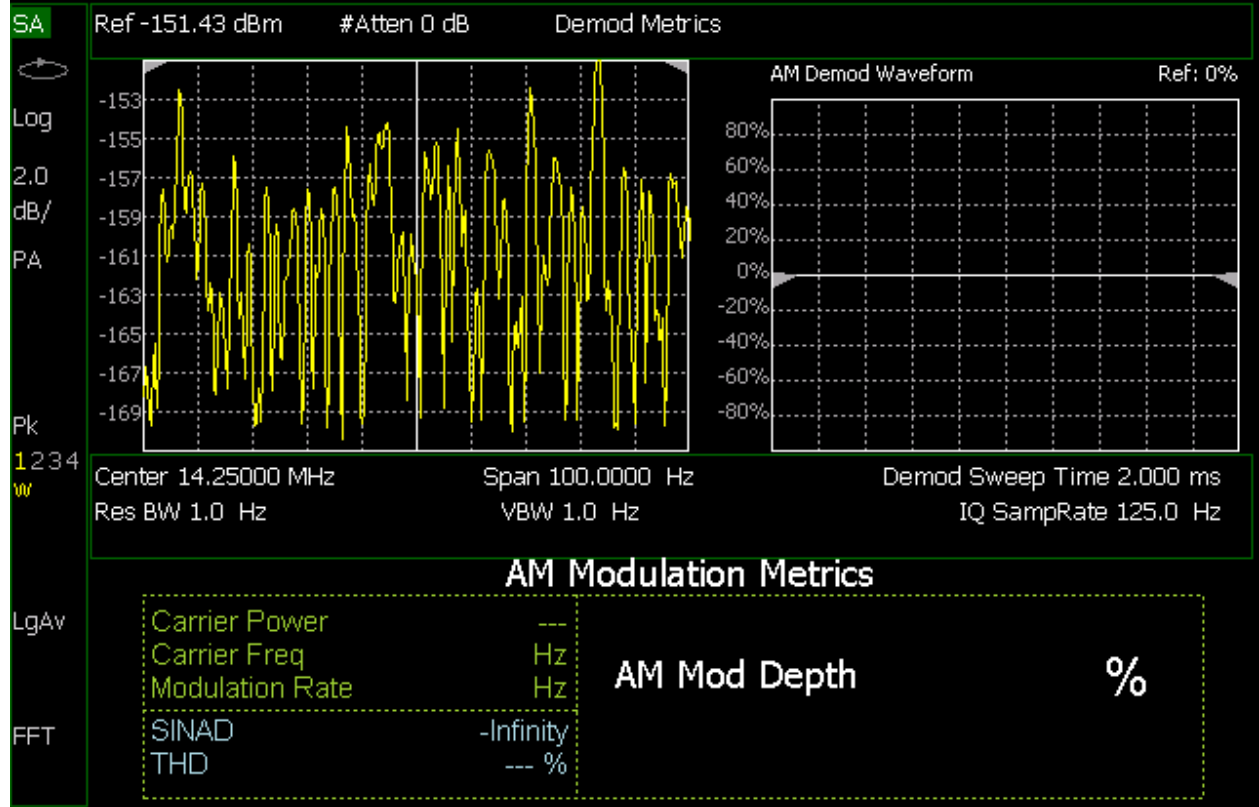



SA Ref -154.18 dBm #Atten 0 dB Demod Metrics

Log
2.0
dB/
PA
Pk
1 2 3 4
w



Center 18.25000 MHz Span 100.0000 Hz Demod Sweep Time 2.000 ms
Res BW 1.0 Hz VBW 1.0 Hz IQ SampRate 125.0 Hz

AM Demod Waveform Ref: 0%

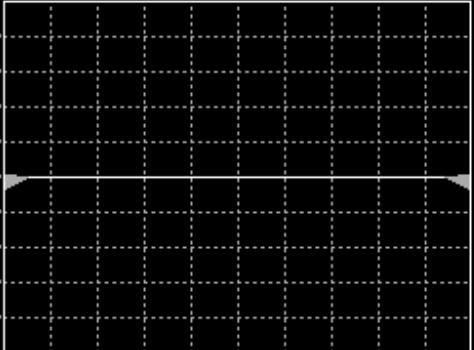

AM Modulation Metrics

Carrier Power	--		
Carrier Freq	Hz		
Modulation Rate	Hz		
SINAD	-Infinity		
THD	-- %		
		AM Mod Depth	%

LgAv
FFT

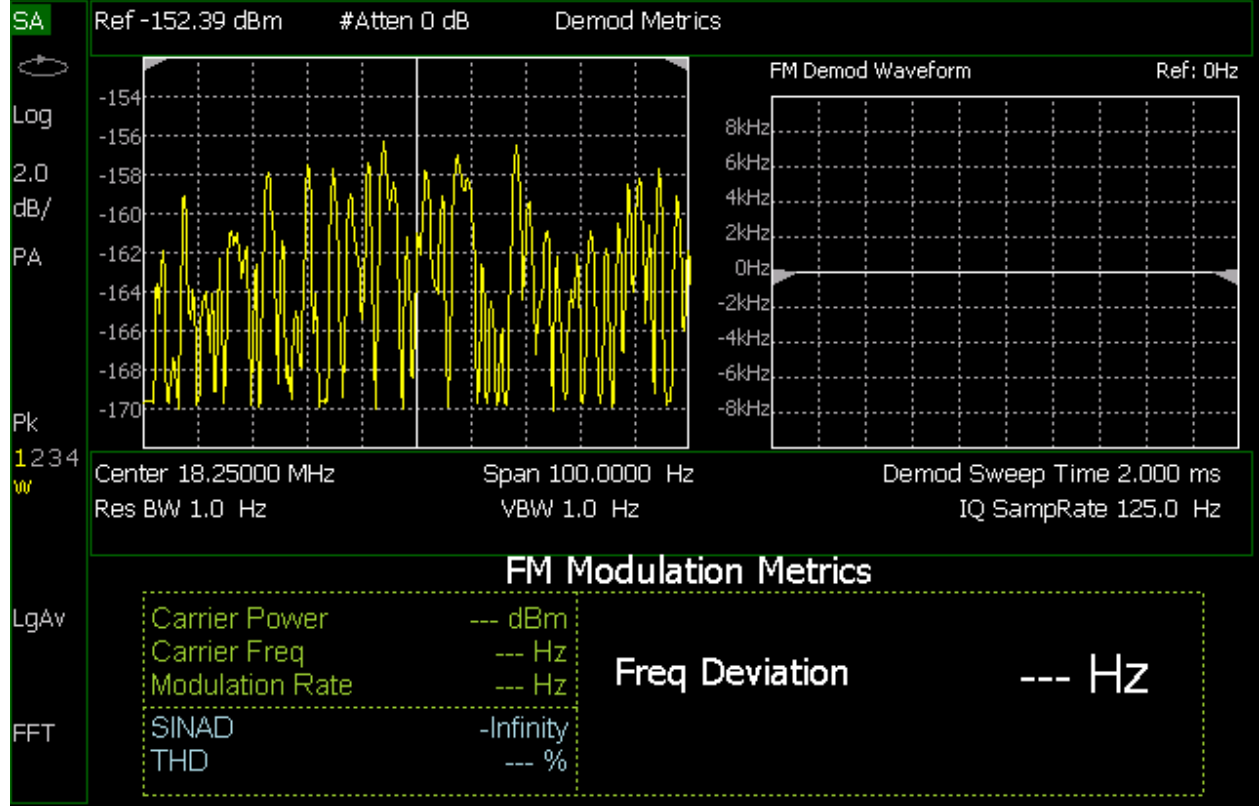

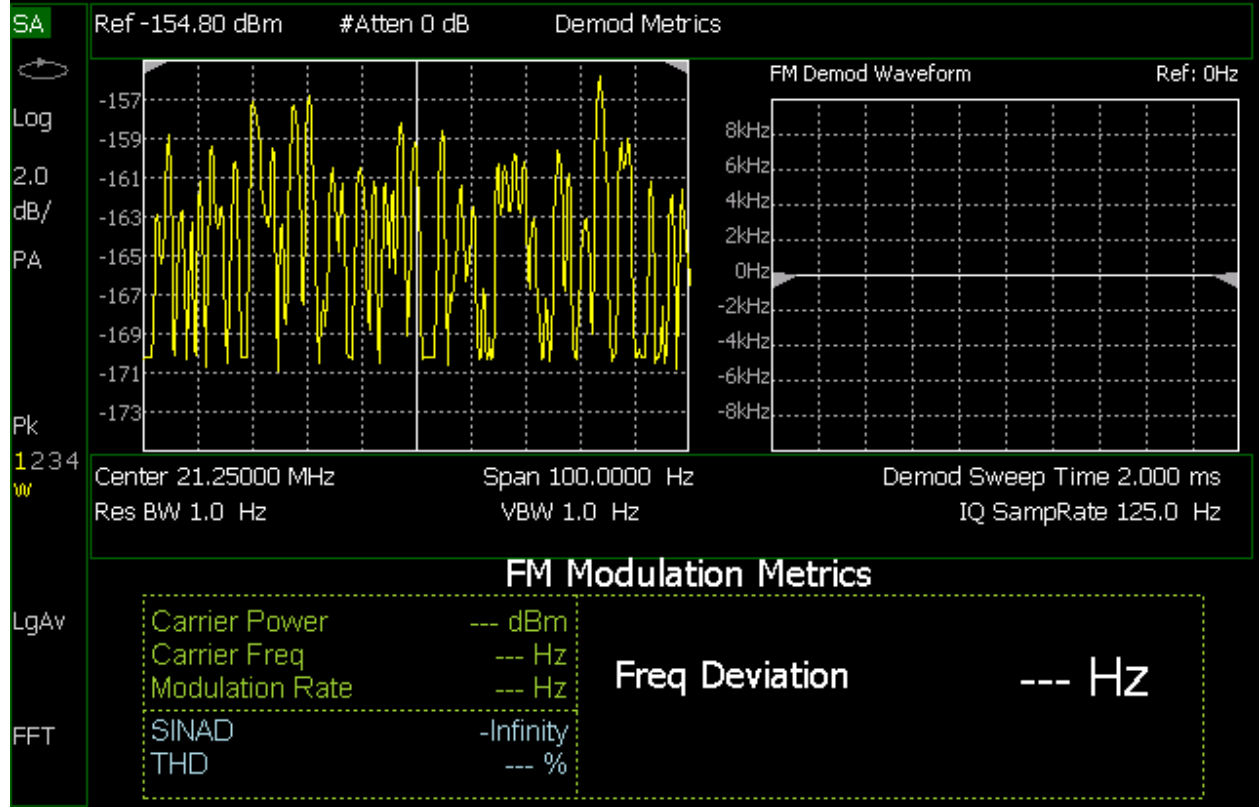

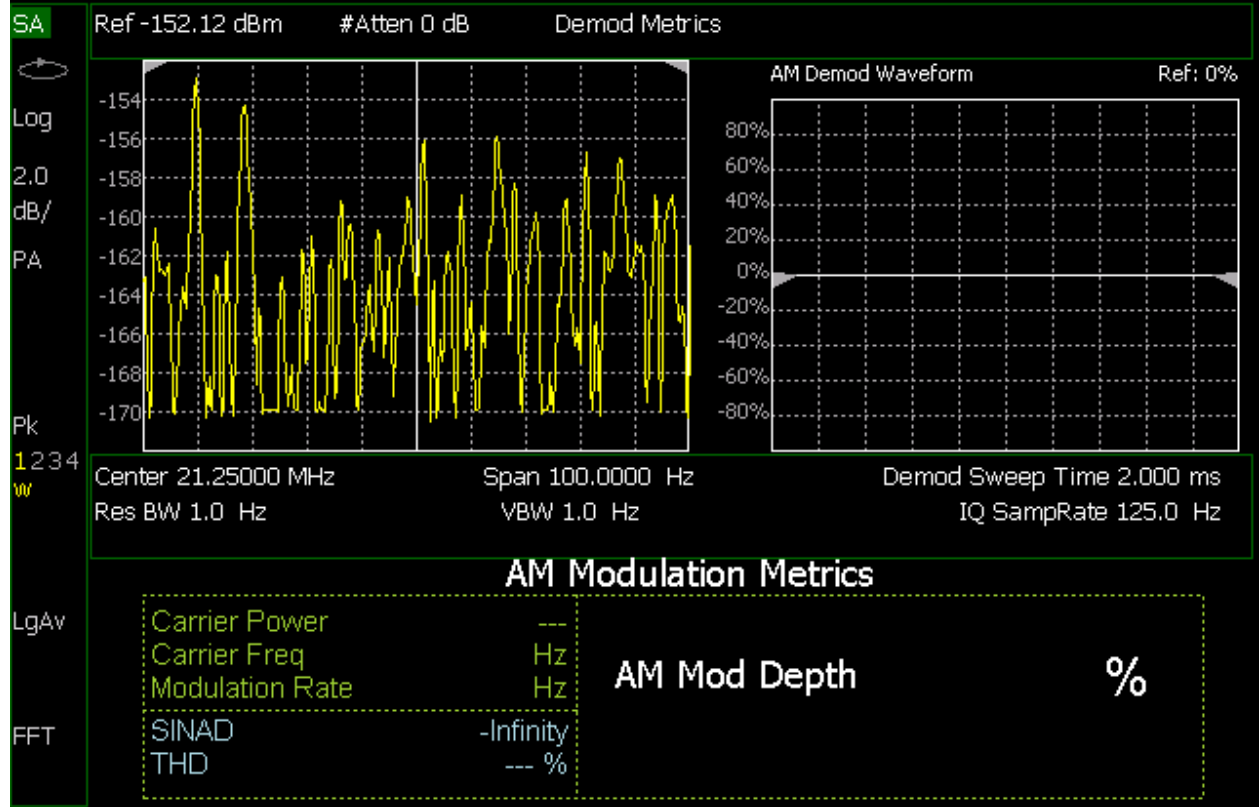

SA Ref -154.84 dBm #Atten 0 dB Demod Metrics

Log
2.0 dB/PA
Pk
1234 w



Center 28.50000 MHz Span 100.0000 Hz Demod Sweep Time 2.000 ms
Res BW 1.0 Hz VBW 1.0 Hz IQ SampRate 125.0 Hz

AM Demod Waveform Ref: 0%

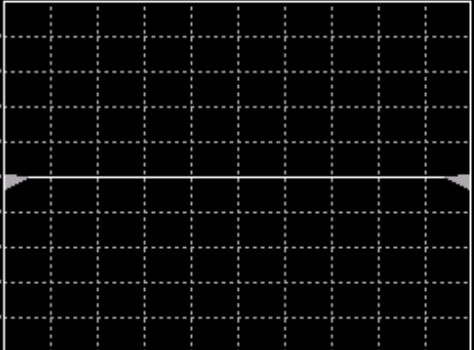

AM Modulation Metrics

Carrier Power	--		
Carrier Freq	Hz		
Modulation Rate	Hz		
SINAD	-Infinity		
THD	-- %		
		AM Mod Depth	%

LgAv
FFT

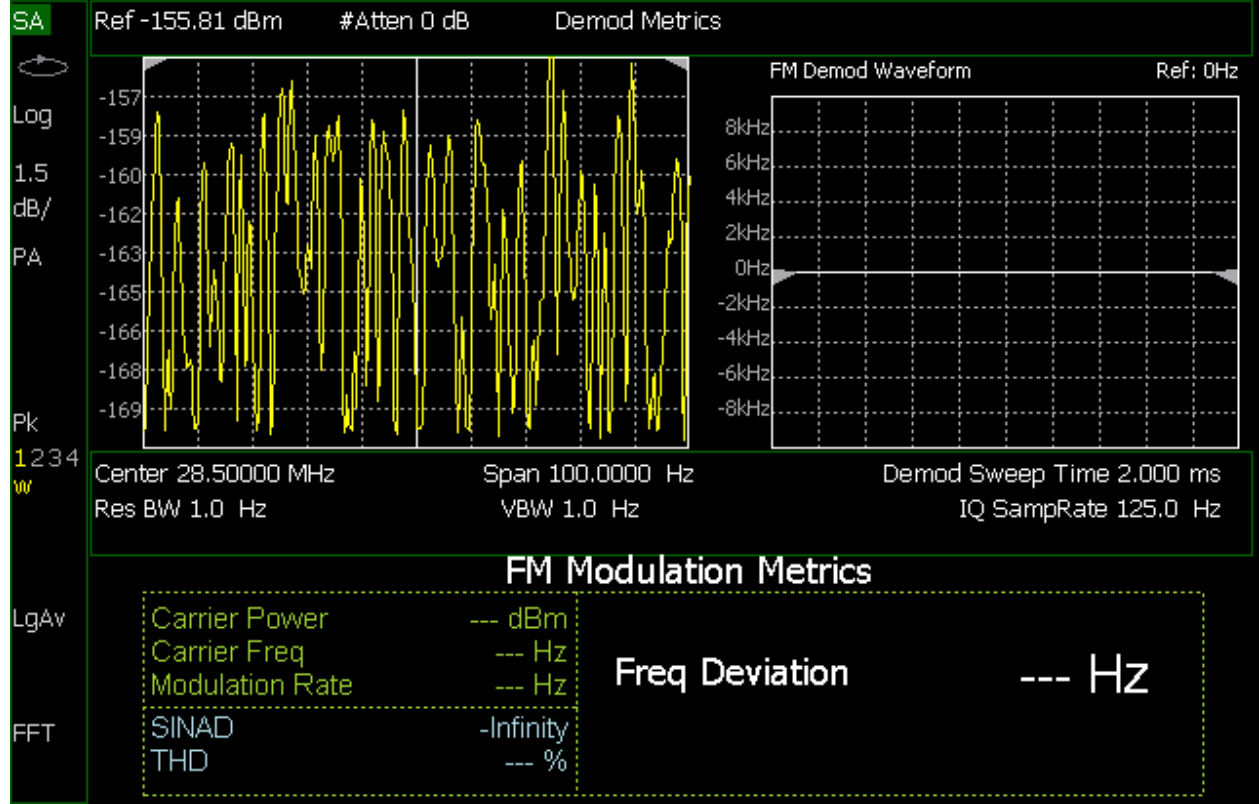

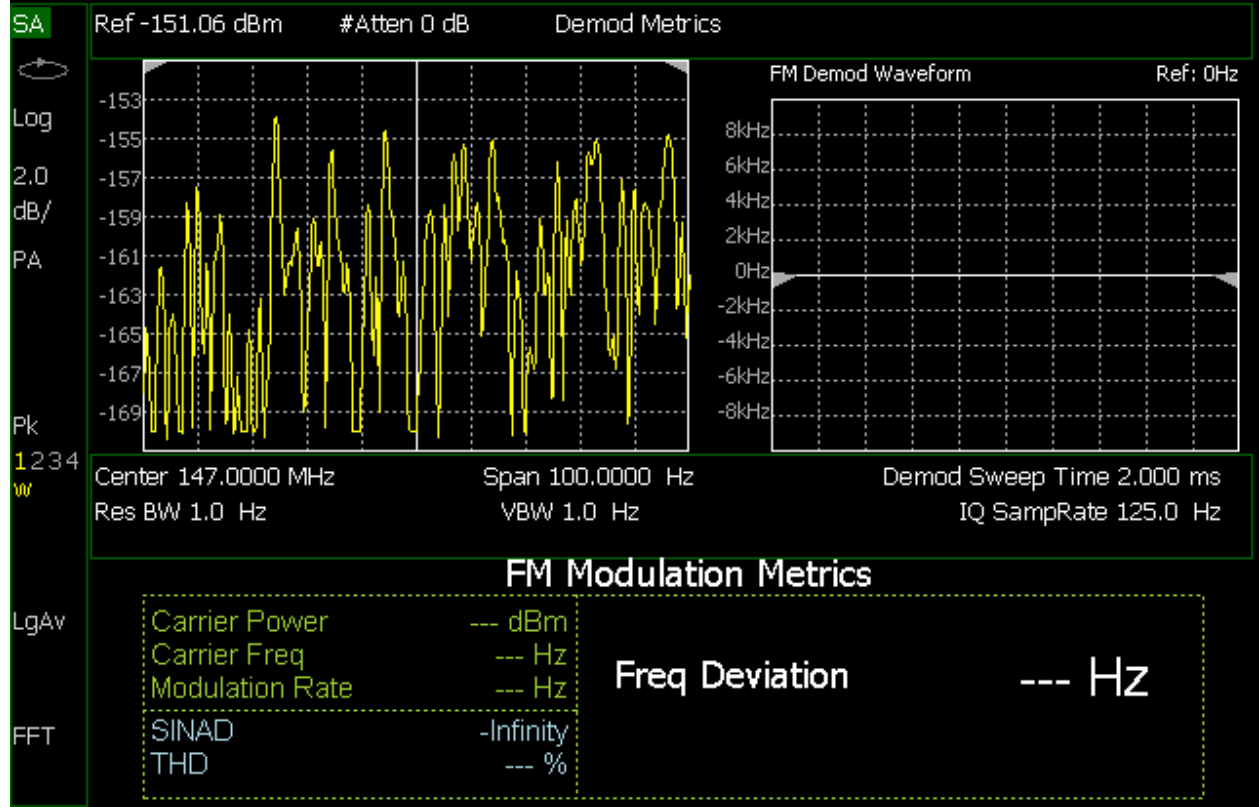

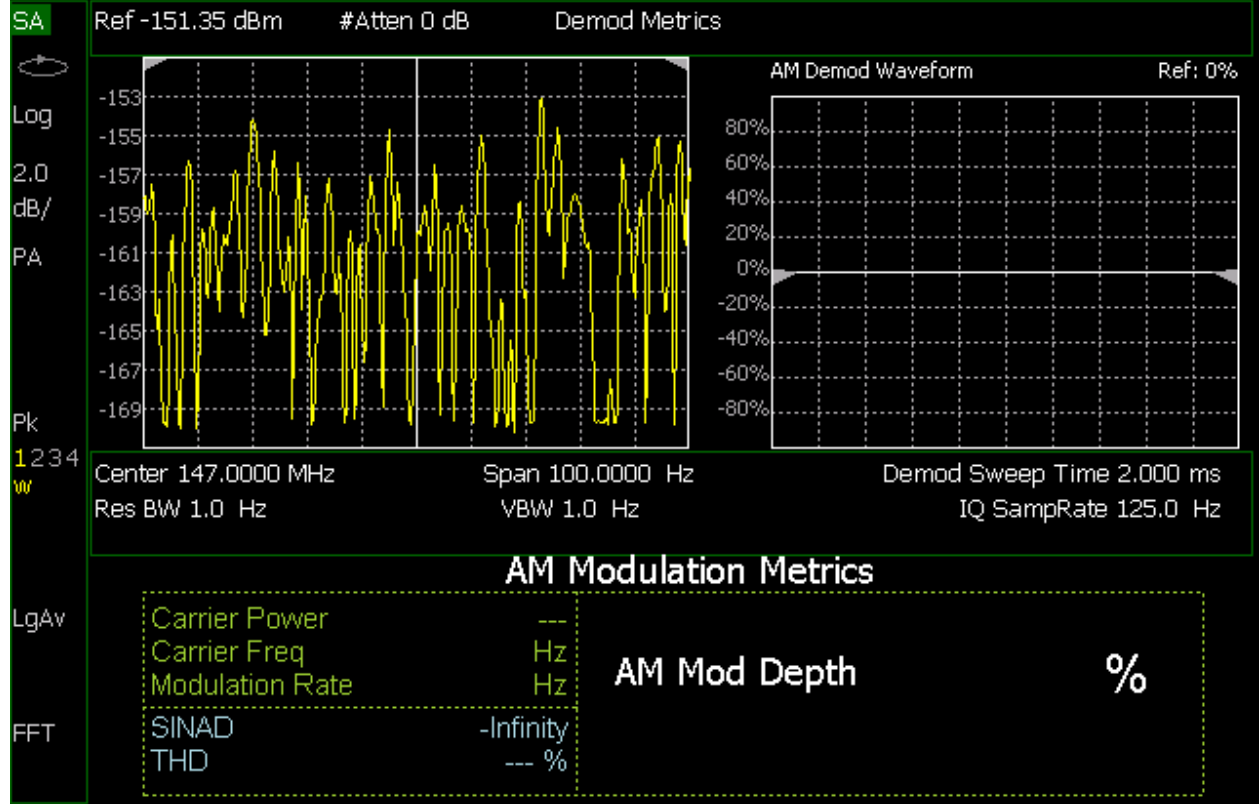

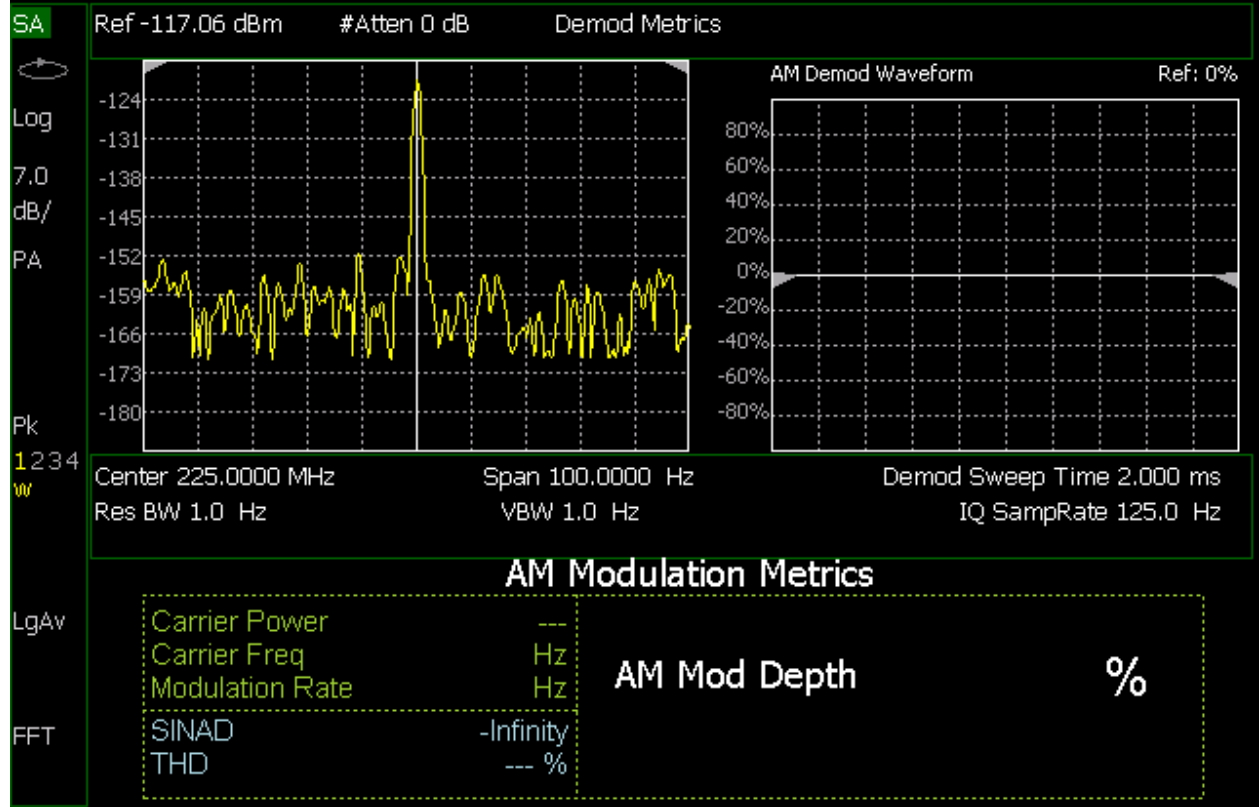

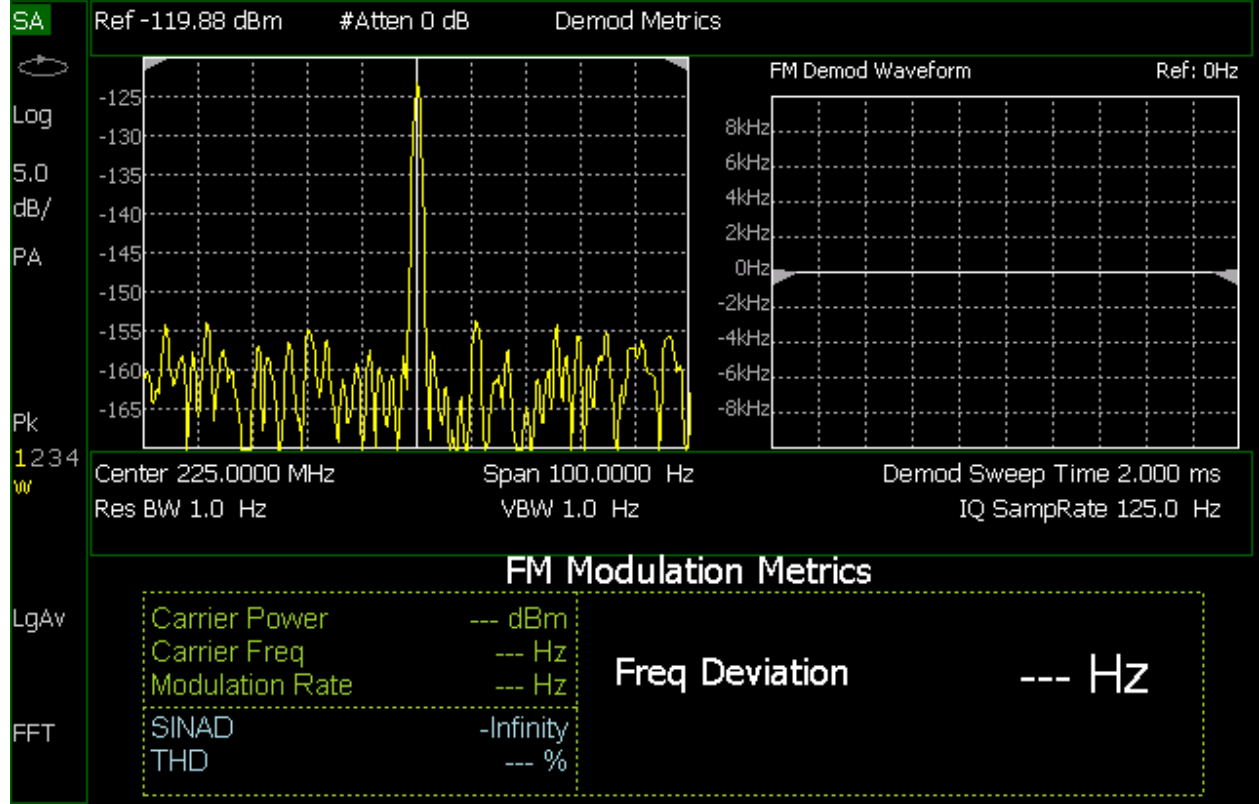

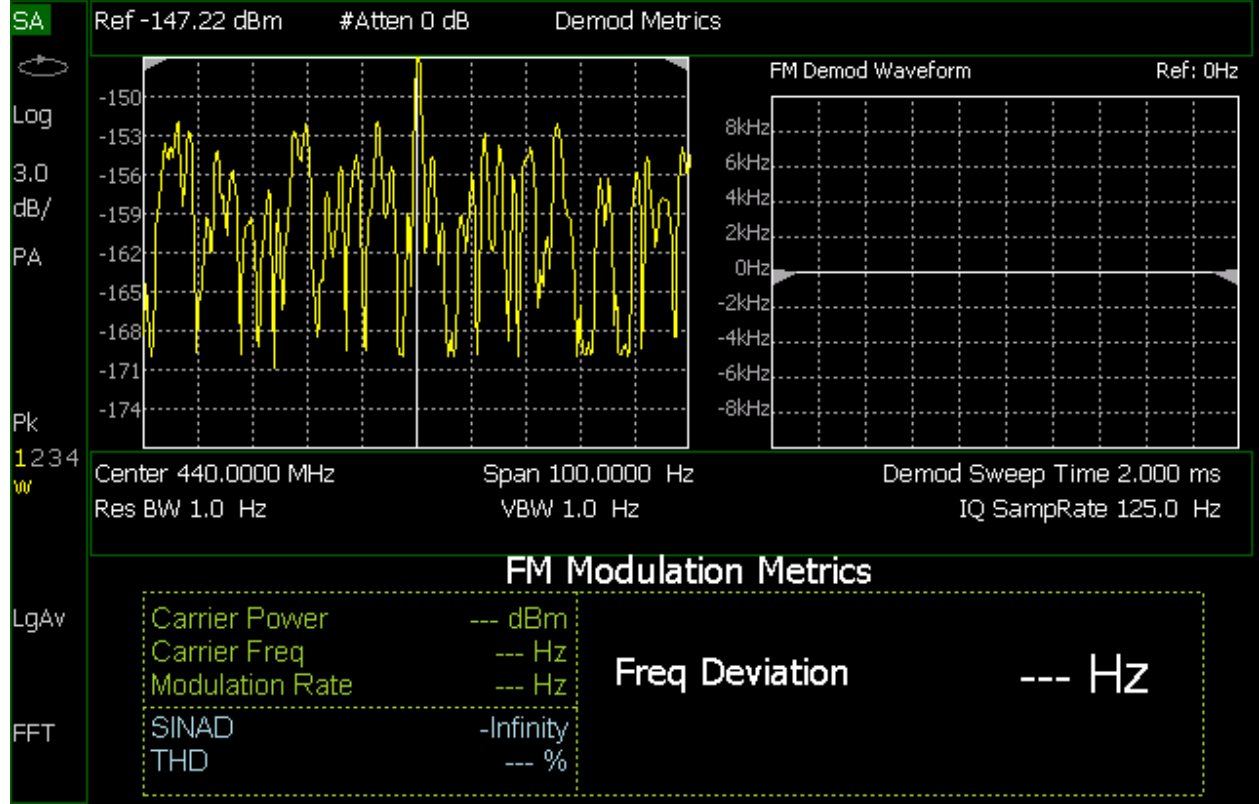

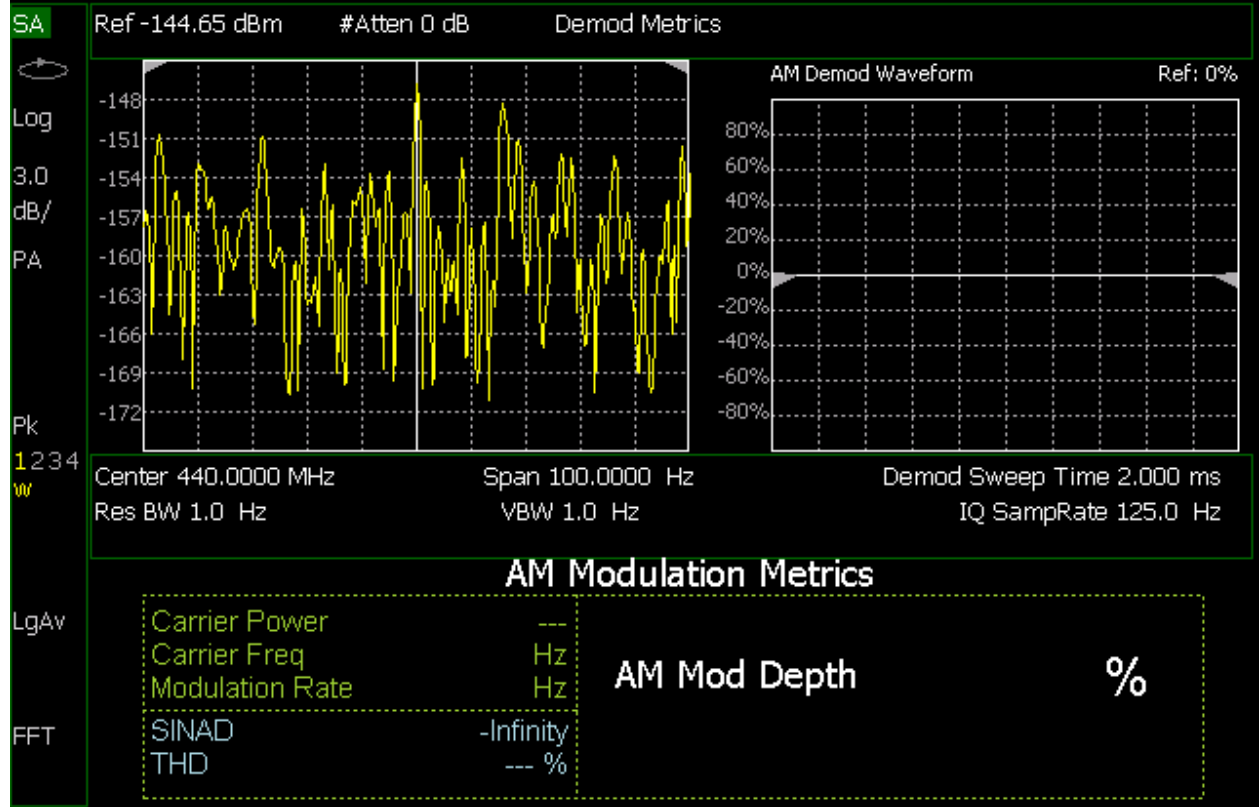

SA Ref -152.16 dBm #Atten 0 dB Demod Metrics

Log
2.0
dB/
PA
Pk
1 2 3 4
w

Center 155.0000 MHz Span 100.0000 Hz Demod Sweep Time 2.000 ms
Res BW 1.0 Hz VBW 1.0 Hz IQ SampRate 125.0 Hz

FM Demod Waveform Ref: 0Hz

8kHz
6kHz
4kHz
2kHz
0Hz
-2kHz
-4kHz
-6kHz
-8kHz

LgAv

FFT

FM Modulation Metrics

Carrier Power	--- dBm	Freq Deviation	--- Hz
Carrier Freq	--- Hz		
Modulation Rate	--- Hz		
SINAD	-Infinity		
THD	--- %		

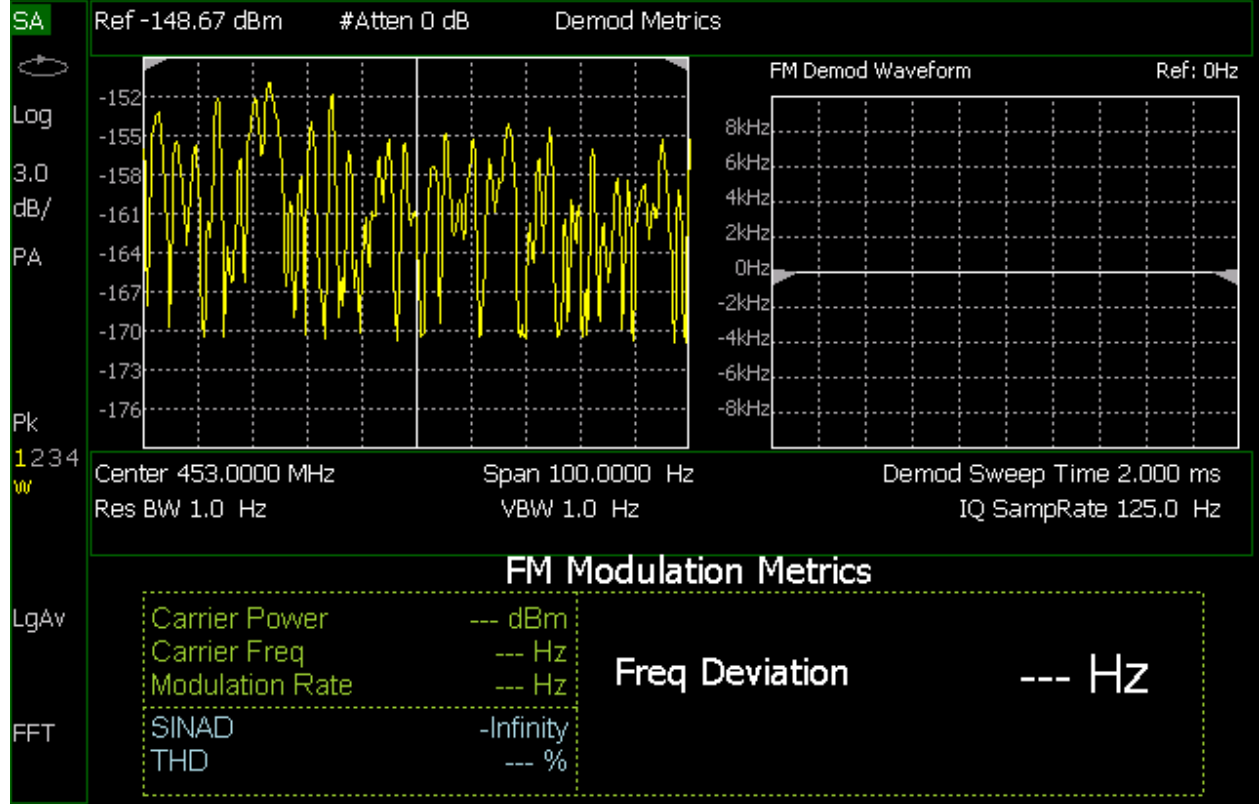

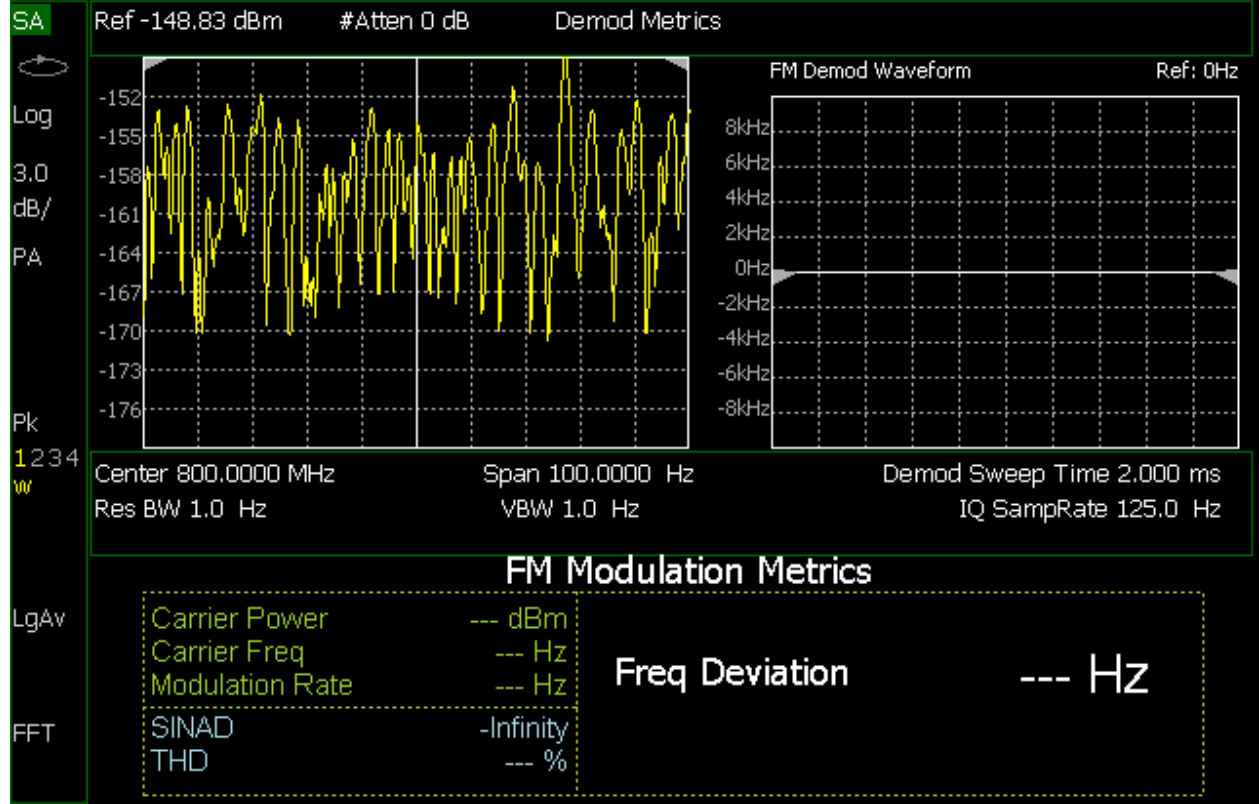

MITIGATION

RF filters are commonly used in televisions and radios to minimize interference. They work by allowing certain frequencies to pass through while blocking others. There are different types of RF filters, including bandpass filters, which only allow frequencies within a certain range to pass through, and notch filters, which block a specific frequency.

To use these filters, you would need to identify the frequencies that are causing interference. Then, the filter can be adjusted to block these frequencies.

High-pass filters allow frequencies higher than a certain cutoff frequency to pass through, and block lower ones. Conversely, low-pass filters allow frequencies lower than a cutoff frequency to pass through, and block higher ones. These can be useful if the interference is coming from a frequency that's consistently either high or low.

While these methods can reduce interference, they might not eliminate it completely. The specific type of filter or method needed will depend on the specific source of the interference.

REFERENCES

AirNav. (May 2023). 3NY0 - Ranch Airport. Retrieved June 2, 2023, from <https://www.airnav.com/airport/3ny0>

AirNav. (May 2023). 8NY5 - Mariaville Aerodrome. Retrieved June 2, 2023, from <https://www.airnav.com/airport/8NY5>

AirNav. (May 2023). ALB - Albany International Airport. Retrieved June 2, 2023, from <https://www.airnav.com/airport/alb>

AirNav. (May 2023). NY05 - Hogan Airport. Retrieved June 2, 2023, from <https://www.airnav.com/airport/NY05>

AirNav. (May 2023). NY87 - Amsterdam Airport. Retrieved June 2, 2023, from <http://www.airnav.com/airport/NY87>

AirNav. (May 2023). SCH - Schenectady County Airport. Retrieved June 2, 2023, from <https://www.airnav.com/airport/sch>

Federal Aviation Administration (FAA). (2023, February 22). Wind Turbine FAQs. Retrieved June 21, 2023, from <https://oeaaa.faa.gov/oeaaa/external/searchAction.jsp?action=showWindTurbineFAQs>

Federal Aviation Administration. (2023, April 20). Appendix 12: Pilot/Controller Glossary. Aeronautical Information Manual (AIM). Retrieved from https://www.faa.gov/air_traffic/publications/atpubs/pham_html/appendix12.html

IT&T Corporation. (6th ed.). Radar fundamentals. In Reference Data for Radio Engineers (pp. 1-18). Howard W. Sams & Co.

Krug, F., & Lewke, B. (2009). Electromagnetic interference on large wind turbines. *Energies*. <https://doi.org/10.3390/en20401118>

RadioReference. (Rev: 2.0.6844). Database ID 2248. Retrieved June 2, 2023, from <https://www.radioreference.com/db/aid/2248>

Sasarita, G., & Wright, C. R. (2013). The Electromagnetic Impact of Wind Turbines. Joint Applied Project. Naval Postgraduate School.

WindExchange. (2023, June 16). Government Review Process for Radar Interference. Retrieved from <https://windexchange.energy.gov/projects/radar-interference-review-process>

APPENDIX A - BACKGROUND

A2.1 List of FM Stations Within 50-Mile Radius of Proposed Site

<u>Call</u>	<u>Ch.</u>	<u>Freq</u> <u>(MHz)</u>	<u>Cls</u>	<u>City</u>	<u>St</u>	<u>ERP-kW</u>	<u>Dist</u>	<u>Azi</u>
WVCR-FM	202	88.3	B1	Loudonvill	NY	2.8	31.9	145
WMHY	203	88.5	A	Richfield	NY	0.61	59.3	275.4
WMHT-FM	206	89.1	B	Schenectad	NY	6.1	32.5	147.4
WGOR.C	207	89.3	A	Lake Georg	NY	0.012	71.6	31.6
WRUC	209	89.7	A	Schenectad	NY	0.1	24.8	103.9
WSSK	209	89.7	A	Saratoga S	NY	0.05	52.2	46.7
WOPG-FM	210	89.9	B1	Esperance	NY	1.4	38.8	254
WANZ	211	90.1	A	Stamford	NY	0.23	66.4	212.9
WLJH	214	90.7	B1	Glens Fall	NY	0.65	71.6	31.6
WPGL	214	90.7	A	Pattersonv	NY	0.027	12.8	101.9
WGXC	214	90.7	A	Acra	NY	3.3	63.9	160.9
WCDB	215	90.9	A	Albany	NY	0.1	38.7	121.8
WNGG	215	90.9	A	Gloversvil	NY	1.5	28.3	335.1
WSPN	216	91.1	A	Saratoga S	NY	0.25	43.7	54.6
WMHU	216	91.1	A	Cold Brook	NY	0.38	72.7	294.6
WIOX	217	91.3	B1	Roxbury	NY	1.1	62.7	204.4
WVHC	218	91.5	A	Herkimer	NY	0.35	66.2	285.9
WRPI	218	91.5	B1	Troy	NY	10	47	115.7
WNGN	220	91.9	A	Argyle	NY	2	74.7	58
WFLY	222	92.3	B	Troy	NY	17	31.9	144.6
WOOG-LP	224	92.7	L1	Troy	NY	0.1	58.5	109.3
W224BI	224	92.7	D	Wells	NY	0.01	57.4	353.5
WGFR	224	92.7	D	Glens Fall	NY	0.013	67.7	43.5
W225BM	225	92.9	D	Scotia	NY	0.01	13.2	100.6
W226CP	226	93.1	D	Glens Fall	NY	0.25	68.6	42.5
W226AC	226	93.1	D	Troy	NY	0.25	49.5	100.9
W226CO	226	93.1	D	Gloversvil	NY	0.25	40.6	13
W227DW	227	93.3	D	Saratoga S	NY	0.25	41	56.8
WCAN	227	93.3	A	Canajohari	NY	6	30.3	275.2
WZCR	228	93.5	A	Hudson	NY	5.8	78.5	151
WLGR	228	93.5	A	Warrensbur	NY	0.12	71.6	31.6
WYAI	229	93.7	A	Scotia	NY	1.25	12.9	97.5
W230DK	230	9.39	D	Albany	NY	0.012	59.5	106.9

W231CF	231	94.1	D	Gloversvil	NY	0.206	28.2	335.1
W232CE	232	94.3	D	Cobleskill	NY	0.25	31.1	216.1
WYKV	233	94.5	A	Ravena	NY	3	45.6	140.2
WBAR-FM	234	94.7	A	Lake Luzer	NY	1.25	61.5	38.4
W235AY	235	94.9	D	Albany	NY	0.25	32	144.5
WYJB	238	95.5	B	Albany	NY	12	32	144.9
W240EC	240	95.9	D	Albany	NY	0.25	50.2	117.2
WCQL	240	95.9	A	Queensbury	NY	0.38	71.6	31.6
WAJZ	242	96.3	A	Voorheesvi	NY	0.47	31.9	145
WYVS	243	96.5	A	Speculator	NY	2.6	73.3	351.4
WMHH	244	96.7	A	Clifton Pa	NY	4.7	29.5	88.4
W245DA	245	96.9	D	South Glen	NY	0.25	69.1	42.5
W246DS	246	97.1	D	Ballston S	NY	0.25	33.2	71.1
W246BJ	246	97.1	D	Hudson	NY	0.2	77.8	151.7
W247BJ	247	97.3	D	Glens Fall	NY	0.038	67.7	44.1
WMYY	247	97.3	A	Schoharie	NY	0.8	27	187.3
W247BM	247	97.3	D	Cooperstow	NY	0.01	59.1	248.9
W248BL	248	97.5	D	Speculator	NY	0.01	73.3	351.4
W248AX	248	97.5	D	Albany	NY	0.1	41.4	119.4
WHMV-LP	248	97.5	L1	Mohawk	NY	0.1	66.1	282.1
W248BG	248	97.5	D	Durham	NY	0.25	52.4	179.9
WEXT	249	97.7	A	Amsterdam	NY	1.6	13.1	16.1
WRIP-FM	250	97.9	D	Hunter	NY	0.035	74.6	180.3
W250CX	250	97.9	D	Saint John	NY	0.25	40.6	290.7
WRIP	250	97.9	A	Windham	NY	0.58	65.3	182.9
W250CC	250	97.9	D	Glens Fall	NY	0.25	69.1	42.5
WTRY-FM	252	98.3	A	Rotterdam	NY	6	18.9	137.9
W252DO	252	98.3	D	Herkimer	NY	0.25	68.7	288.1
WCKM-FM	253	98.5	A	Lake Georg	NY	0.37	71.6	31.6
W254DA	254	98.7	D	Albany	NY	0.08	49.5	100.9
WOOS-LP	255	98.9	L1	Schenectad	NY	0.1	21.3	116.8
W256BU	256	99.1	D	Albany	NY	0.25	49.5	100.9
WRVE	258	99.5	B	Schenectad	NY	14.5	32.1	144.3
WBGK	259	99.7	A	Newport Vi	NY	1.4	72	294.8
W260CH	260	99.9	D	Albany	NY	0.25	50.2	117.2
W261DP	261	100.1	D	Duanesburg	NY	0.25	8.7	154.4
WDHI	262	100.3	A	Delhi	NY	1.6	74.4	222.7
WFFG-FM	262	100.3	B1	Warrensbur	NY	1.45	71.6	31.6
W262AC	262	100.3	D	Little Fal	NY	0.005	53.2	288.2

W263CG	263	100.5	D	Albany	NY	0.25	32	119
WKLI-FM	265	100.9	A	Albany	NY	6	32	119
W266BX	266	101.1	D	Jefferson	NY	0.01	78.3	159.9
WBUG-FM	266	101.1	A	Fort Plain	NY	1.25	45.6	271.2
WJKE	267	101.3	A	Stillwater	NY	2.9	46.7	70.4
WNYQ	269	101.7	A	Hudson Fal	NY	4.6	72.3	38.7
WJIV	270	101.9	B	Cherry Val	NY	11.5	39.3	257.3
W271DP	271	102.1	D	Lake Georg	NY	0.01	71.6	31.6
WKKF	272	102.3	A	Ballston S	NY	4.1	29.5	88.4
W274AT	274	102.7	D	Little Fal	NY	0.065	57.7	283.6
WLPP-LP	275	102.9	L1	Palenville	NY	0.1	79.2	167.8
W275BS	275	102.9	D	Johnstown	NY	0.25	17.8	322.8
WGY-FM	276	103.1	A	Albany	NY	5.6	50.2	117.2
WQSH	278	103.5	B	Cobleskill	NY	50	24.4	297.3
WPBZ-FM	280	103.9	A	Rensselaer	NY	6	48.7	130.8
W281AK	281	104.1	D	Amsterdam	NY	0.01	13	15.5
W282BI	282	104.3	D	Coxsackie	NY	0.01	60	150.8
W282AD	282	104.3	D	East Windh	NY	0.002	59.5	174.4
W282CU	282	104.3	D	Northville	NY	0.05	39.7	6.8
W283BP	283	104.5	D	Stamford	NY	0.04	60.4	209.7
WTMM	283	104.5	A	Mechanicvi	NY	5	29.5	88.4
W284BZ	284	104.7	D	Amsterdam	NY	0.25	4.3	7.7
WINU	285	104.9	A	Altamont	NY	0.53	31.9	145
WBLN-LP	285	104.9	L1	Glens Fall	NY	0.1	67.7	43.9
W286DI	286	105.1	D	Cambridge	NY	0.25	68.4	74
W286CD	286	105.1	D	Gloversvil	NY	0.25	19.9	328.6
WOOC-LP	287	105.3	L1	Troy	NY	0.1	49.4	108.2
WGKR	287	105.3	A	Grand Gorg	NY	0.06	60.5	209.7
WSKU	288	105.5	A	Little Fal	NY	2.25	58	283.4
WQBK-FM	289	105.7	B1	Malta	NY	7.1	49.5	100.9
W290CI.	290	105.9	D	Cooperstow	NY	0.01	59.1	248.9
W290CI	290	105.9	D	Cooperstow	NY	0.01	59.1	248.9
W290BE	290	105.9	D	Hudson	NY	0.25	78.3	159.9
W291BY	291	106.1	D	Albany	NY	0.25	49.5	100.9
WPYX	293	106.5	B	Albany	NY	15.5	32	145.1
W295CZ	295	106.9	D	Amsterdam	NY	0.019	10.8	22.8
WOOA-LP	295	106.9	L1	Albany	NY	0.1	44.4	122.2
WKBE	296	107.1	A	Corinth	NY	2.85	55.4	41.5
WCAA-LP	297	107.3	L1	Albany	NY	0.1	45.7	123.2

WGNA-FM	299	107.7	B	Albany	NY	12.5	32	144.5
---------	-----	-------	---	--------	----	------	----	-------

A3.1 Map of Known AT&T 4G Base Station Sites Near Proposed Site

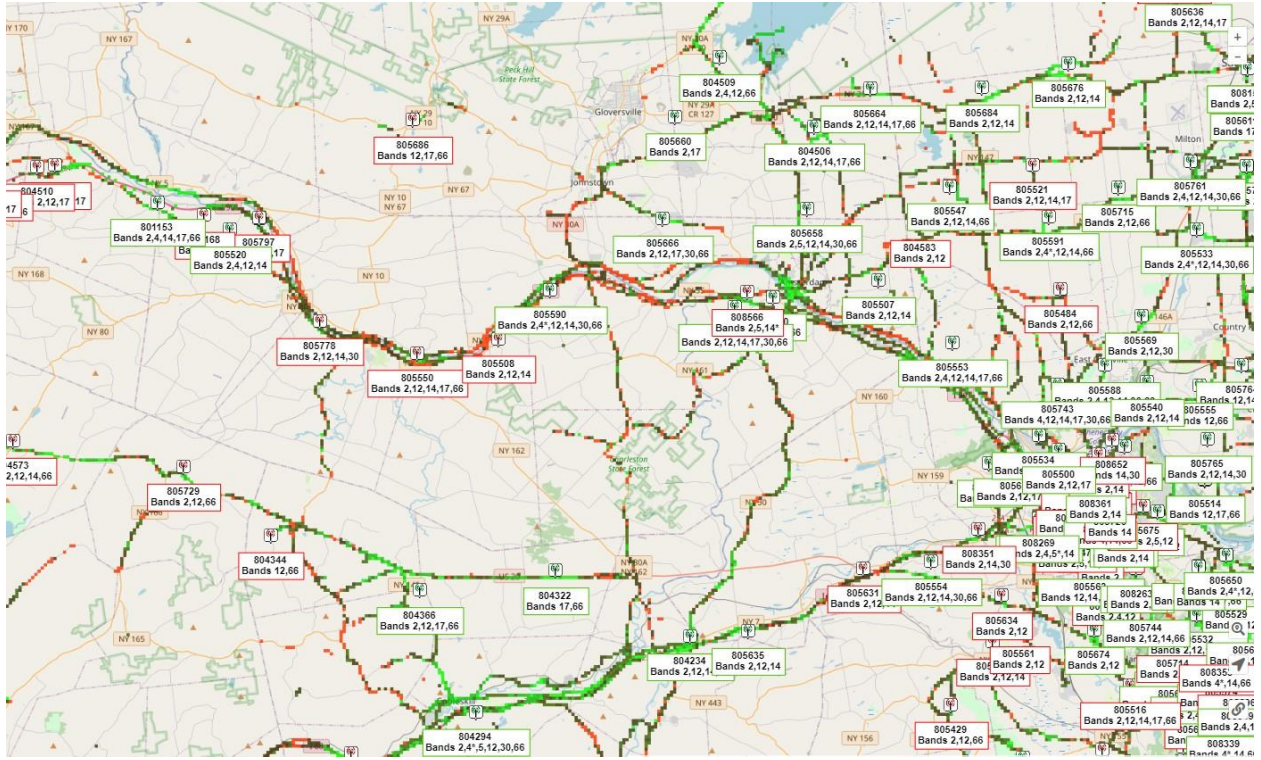

A3.5 Map of Known Verizon 4G Base Station Sites Near Proposed Site

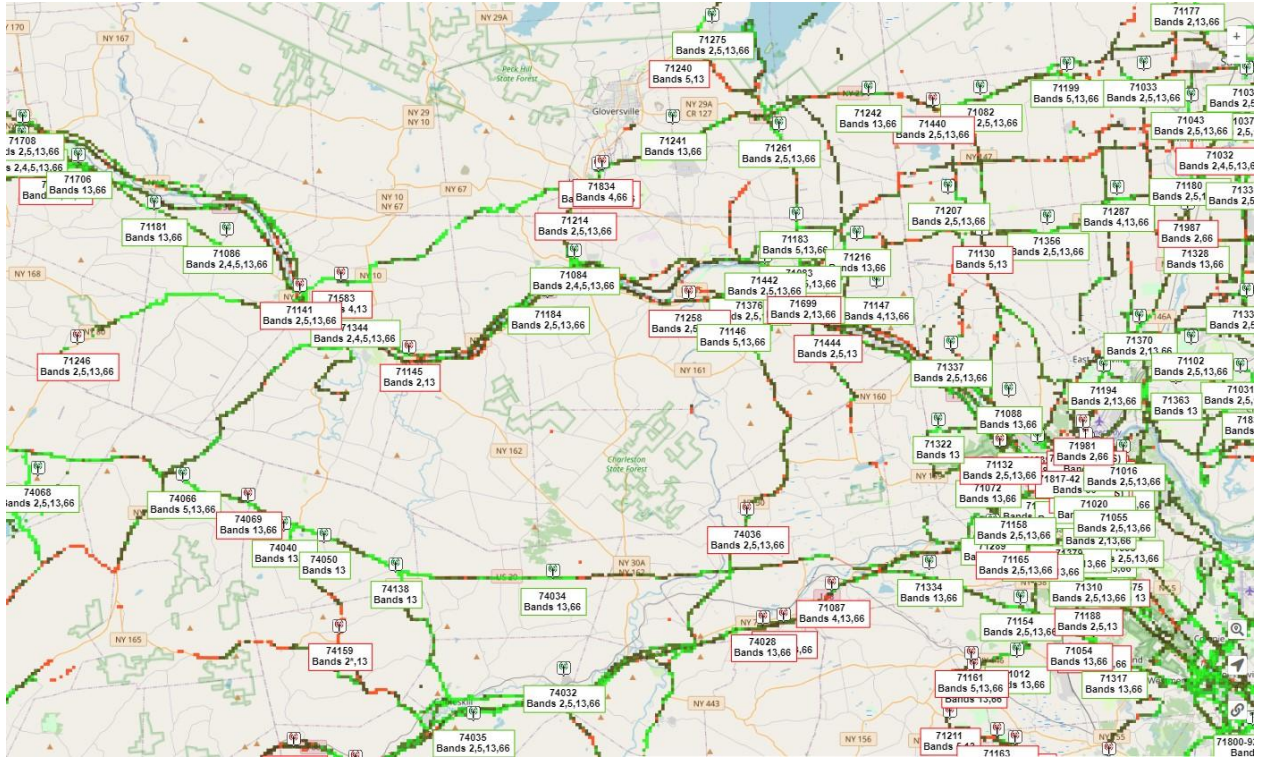

APPENDIX B - TEST DETAILS

B1.1 Keysight FieldFox N9914A Datasheet

FieldFox Handheld Analyzers

4/6.5/9/14/18/26.5/32/44/50 GHz

N9913A

N9914A

N9915A

N9916A

N9917A

N9918A

N9950A

N9951A

N9952A

N9925A

N9926A

N9927A

N9928A

N9935A

N9936A

N9937A

N9938A

N9960A

N9961A

N9962A



Table of Contents

Definitions.....	3
Cable and Antenna Analyzer and Vector Network Analyzer	4
Corrected Measurement Uncertainty	15
TDR Cable Measurements (Option 215)	22
VNA Time Domain (Option 010)	23
Mixed-Mode S-Parameters (Option 212).....	23
Vector Voltmeter (VVM) (Option 308).....	24
Spectrum Analyzer (Option 233 on Combination Analyzers)	25
Tracking Generator or Independent Source	35
Real-Time Spectrum Analyzer (RTSA) (Option 350).....	37
I/Q Analyzer (IQA) (Option 351).....	38
Noise Figure (NF) (Option 356)	40
Spectrum Analyzer IF Output.....	46
Preamplifier (Option 235).....	47
Interference Analyzer and Spectrogram (Option 236).....	47
Channel Scanner (Option 312)	47
89600 VSA Software.....	47
Over-the-Air (OTA) LTE FDD/TDD (Option 370/371)	48
Over-the-Air (OTA) 5GTF (Option 377)	49
Indoor and Outdoor Mapping (Option 352).....	51
EMF Measurements (Option 358).....	52
AM/FM Analog demodulation, Tune and Listen (Option 355).....	53
Spectrum Analyzer Time Gating (Option 238).....	54
Reflection Measurements (RL, VSWR) (Option 320, applicable to SA only models).....	54
Extended Range Transmission Analysis (ERTA) (Option 209)	55
Built-in Power Meter (Option 310).....	61
External USB Power Sensor Support (Option 302)	62
Pulse Measurements (Option 330)	62
USB Power Sensor Measurements versus Frequency (Option 208)	62
Built-In GPS Receiver (Option 307)	64
DC Bias Variable-Voltage Source (Option 309).....	64
Remote Control Capability (Option 030)	65
EMI measurements (Option 361)	64
General Information	65
FieldFox Physical Dimensions	70
Carry Precision With You	73

This data sheet provides the specified and typical performance of the FieldFox family of portable analyzers. This data sheet should be used in conjunction with the technical overviews and configuration guide, for a complete description of the analyzers.

The specifications and measurement capabilities listed in this document require certain options on the FieldFox analyzer. Refer to the FieldFox Configuration Guide to obtain option information. The configuration guide is the main resource for option/measurement capability information (<https://www.keysight.com/us/en/assets/7018-03329/configuration-guides/5990-9836.pdf>).

Definitions

Specification (spec)

Specifications include guardbands to account for the expected statistical performance distribution, measurement uncertainties, and changes in performance due to environmental conditions. Specifications are warranted performance. FieldFox must be within its calibration cycle. No warm-up required for the spectrum analyzer specifications listed on pages 25 through 50.

Typical

Describes additional product performance information not covered by the product warranty. It is performance beyond specifications that 80% of the units exhibit with a 90% confidence level over the temperature range $23 \pm 5^{\circ}\text{C}$, unless otherwise noted. Typical performance does not include measurement uncertainty. FieldFox must be within its calibration cycle.

Nominal

A general, descriptive term or design parameter. It is not tested, and not covered by the product warranty. FieldFox must be within its calibration cycle.

Cable and Antenna Analyzer and Vector Network Analyzer

The performance listed in this section applies to the cable and antenna analyzer (referred to as CAT) and vector network analyzer (VNA) capabilities available in the following models:

FieldFox RF & microwave (combination) analyzers:	N9913A, N9914A, N9915A, N9916A, N9917A, N9918A N9950A, N9951A, N9952A
FieldFox microwave vector network analyzers:	N9925A, N9926A, N9927A, N9928A

NOTE: Combination analyzers = Cable and antenna tester (CAT) + Vector network analyzer (VNA) + Spectrum analyzer (SA)

Frequency specifications

	Models	Frequency range
N991xA, N992xA	N9913A	30 kHz to 4 GHz
	N9913A (with option V5K)	5 kHz to 4 GHz
	N9914A	30 kHz to 6.5 GHz
	N9914A (with option V5K)	5 kHz to 6.5 GHz
	N9915A, N9925A	30 kHz to 9 GHz
	N9915A (with option V5K)	5 kHz to 9 GHz
	N9916A, N9926A	30 kHz to 14 GHz
	N9916A (with option V5K)	5 kHz to 14 GHz
	N9917A, N9927A	30 kHz to 18 GHz
	N9917A (with option V5K)	5 kHz to 18 GHz
	N9918A, N9928A	30 kHz to 26.5 GHz
	N9918A (with option V5K)	5 kHz to 26.5 GHz
	N995xA	N9950A
N9951A		300 kHz to 44 GHz
N9952A		300 kHz to 50 GHz
Frequency reference, -10 to 55°C		
Accuracy	± 0.7 ppm (spec) + aging	
	± 0.4 ppm (typical) + aging	
Accuracy, when locked to GPS	± 0.010 ppm (spec)	
Accuracy, when GPS antenna is disconnected	± 0.2 ppm (nominal) ¹	
Aging Rate	± 1 ppm/yr for 20 years (spec), will not exceed ± 3.5 ppm	
Frequency resolution	Spec	
Frequency ≤ 5 GHz	1 Hz	
Frequency ≤ 10 GHz	1.34 Hz	
Frequency ≤ 20 GHz	2.68 Hz	
Frequency ≤ 40 GHz	5.36 Hz	
Frequency ≤ 50 GHz	8.04 Hz	
Data points or resolution		
	101, 201, 401, 601, 801, 1001, 1601, 4001, 10,001	

¹ The maximum drift expected in the frequency reference applicable when the ambient temperature changes ± 5°C from the temperature when the GPS signal was last connected.

Data points or resolution		
Arbitrary number of points settable through front panel and SCPI		
IF bandwidth¹	N991xA, N992xA	N995xA
	3 Hz, 10 Hz, 30 Hz, 100 Hz, 300 Hz, 1 kHz, 3 kHz, 10 kHz, 30 kHz, 100 kHz	10 Hz, 30 Hz, 100 Hz, 300 Hz, 1 kHz, 3 kHz, 10 kHz, 30 kHz, 100 kHz
System impedance		
50 Ω (nominal), 75 Ω with appropriate adapter and calibration kit		

¹ VNA mode only. Recommend using averaging in CAT mode.

Cable and Antenna Analyzer and Vector Network Analyzer (continued)

Test port output specifications

High power in N991xA and N992xA refers to the target output power level of the analyzer when the *Power Setting* is set to *High*. As an example, if you have a frequency sweep from 3 to 6.5 GHz, the analyzer will achieve the power level of -1 dBm across the band.

Low power level for N991xA and N992xA analyzers is a flat -45 dBm across the whole frequency band and is the output of the analyzer when the *Power Setting* is set to *Low*.

High power in the N995xA refers to the target output power level of the analyzer when the *Power Setting* is set to *High*. As an example, if you have a frequency sweep from 39 to 46 GHz, the analyzer will achieve the power level of -2 dBm across the band.

Low power level for N995xA analyzers is the lowest power level that can be set and is the output of the analyzer when the *Power Setting* is set to *Low*.

Max leveled power in the N995xA refers to the maximum leveled (flattened) power that can be achieved across the designated frequency range. For example, if you have a frequency sweep from 32 to 44 GHz and set up the analyzer to measure all four S-parameters, needing both ports 1 and 2, the maximum power the analyzer can be set to is -6 dBm.

Test port output power (dBm), high power	Typical	Nominal
N991xA, N992xA	Port 1 or Port 2	Port 1 or Port 2
30 to 300 kHz	-11	—
> 300 kHz to 2 MHz	-3	-2
> 2 to 625 MHz	-2	-1
> 625 MHz to 3 GHz	1	3
> 3 to 6.5 GHz	-1	1
> 6.5 to 9 GHz	-2	0
> 9 to 14 GHz	-4	-2.5
> 14 to 18 GHz	-6	-4.5
> 18 to 23 GHz	-10	-8.5
> 23 to 26.5 GHz	-12	-11
Test port output power (dBm), low power	Typical	Nominal
N991xA, N992xA	Port 1 or Port 2	Port 1 or Port 2
30 kHz to 26.5 GHz	—	-45 (flattened)

Cable and Antenna Analyzer and Vector Network Analyzer (continued)

Test port output specifications (continued)

Test port output power (dBm), high power	Typical		Nominal
N995xA	Port 1	Port 2	
300 kHz to 2 MHz	-10	-10	—
> 2 MHz to 1 GHz	2	2	—
> 1 to 6.5 GHz	2	0	—
> 6.5 to 18 GHz	4	1	—
> 18 to 39 GHz	1	-2	—
> 39 to 46 GHz	-2	-5	—
> 46 to 50 GHz	-4	-7	—
Test port output power (dBm), low power	Typical		Nominal
N995xA	Port 1	Port 2	
500 kHz to 10 MHz	-35	-38	—
> 10 MHz to 10 GHz	-38	-42	—
> 10 to 20 GHz	-43	-47	—
> 20 to 44 GHz	-44	-50	—
> 44 to 50 GHz	-53	-55	—
Max leveled output power (dBm)	Typical		Nominal
N995xA	Port 1	Port 2	
500 kHz to 10 MHz	-4	-5	—
> 10 MHz to 25 GHz	0	0	—
> 25 to 32 GHz	0	-4	—
> 32 to 44 GHz	-3	-6	—
> 44 to 50 GHz	-7	-10	—
Output power range			
CAT	High, low, and manual. Default (preset) power is high. Manual power is flattened.		
VNA	High, low, and manual. Default (preset) power is manual, -15 dBm. Manual power is flattened.		
Power step size			
	Power settable in 1 dB steps across power range. Flat power, in 1 dB steps, is available across the whole frequency span, nominal.		
Power level accuracy ¹	Typical		
N991xA, N992xA	± 1.5 dB at -15 dBm, for frequencies > 250 kHz		
N995xA	± 0.7 dB at -15 dBm, for frequencies > 500 kHz to 10 MHz ± 0.5 dB at -15 dBm, for frequencies > 10 MHz to 50 GHz		
Power level linearity	Nominal		
N995xA	Port 1 or Port 2, -25 dBm ≤ P < max leveled power		
10 MHz to 50 GHz	± 0.5 dB		

¹ N991xA and N992xA power levels are calibrated in the factory using a broadband power sensor, which means all tones (fundamental and harmonics) are included. N995xA power levels are calibrated based on PNA-X's tuned receiver, which means primarily the fundamental is included across all frequency bands. For older N995xA with series number prefix break <MY/SG/US6224, the broadband power sensor calibration method was used at <10 MHz, resulting in a higher reported combined tone power level.

Cable and Antenna Analyzer and Vector Network Analyzer (continued)

System performance specifications

System dynamic range ^{1,2} (dB), high power, 300 Hz IFBW, 100 point average, Port 1 or Port 2 (-10 to 55 °C)			
	Frequency	Spec	Typical
N991xA, N992xA	> 300 kHz to 9 GHz ³	95	100
	> 9 to 14 GHz	91	97
	> 14 to 18 GHz	90	94
	> 18 to 20 GHz	87	90
	> 20 to 25 GHz	74	79
	> 25 to 26.5 GHz	65	70
N995xA	> 300 kHz to 1 MHz	—	70 (nominal)
	> 1 to 10 MHz	—	100 (nominal)
	> 10 MHz to 20 GHz ⁴	100	110
	> 20 to 44 GHz ⁵	90	100
	> 44 to 50 GHz ⁶	81	90

Measurement stability over temperature	Nominal		
	Frequency	Magnitude (dB/°C)	Phase (deg/°C)
N991xA, N992xA	30 kHz to 15 GHz	± 0.018	—
	> 15 to 26.5 GHz	± 0.080	—
	≤ 15 GHz	± 0.005	± 0.1
N995xA	≤ 25 GHz	± 0.030	± 0.3
	> 25 GHz	± 0.060	± 0.6

Measurement speed (Sweep time)		
CAT	N991xA, N992xA	N995xA
Return loss, 30 kHz to 26.5 GHz, 1-port cal, 1001 points ⁷	673 μs /pt	—
Return loss, 300 kHz to 50 GHz, 1-port cal, 1001 points	—	686 μs /pt
Distance-to-fault, 100-meter cable, 1-port cal, 1001 points ⁷	782 μs /pt	760 μs /pt
VNA	N991xA, N992xA	N995xA
S11 and S21, 30 kHz to 26.5 GHz, enhanced response cal, 100 kHz IF bandwidth, 1001 points ⁸	432 μs /pt	—
S11 and S21, 300 kHz to 50 GHz, enhanced response cal, 100 kHz IF bandwidth, 1001 points	—	478 μs /pt

¹ System dynamic range is measured in the factory with loads on the test ports after a thru normalization.

² For CAT mode, "Insertion loss (2-port)", decrease listed dynamic range specifications by 20 dB, as CAT mode IFBW is fixed at 10 kHz. Can obtain full dynamic range by using S21 measurement in VNA mode with 100 Hz IFBW.

³ < 300 kHz: 63 dB nominal; 2 to 9 MHz: 85 dB spec, 90 dB typical.

⁴ Decrease by 3 dB from 15 to 15.8 GHz for S21.

⁵ Decrease by 5 dB from 21.7 to 22.1 GHz for S21.

⁶ Decrease by 4 dB from 44 to 50 GHz for S21.

⁷ 850 μs /pt; slower speed applicable to FieldFox models with serial number prefix ≤ MY5607/SG5607/US5607 and FieldFox models not upgraded with the fast CPU Option N9910HU-100/200/300.

⁸ 850 μs /pt; slower speed applicable to FieldFox models with serial number prefix ≤ MY5607/SG5607/US5607 and FieldFox models not upgraded with the fast CPU Option N9910HU-100/200/300.

Cable and Antenna Analyzer and Vector Network Analyzer (continued)

Test port input specifications

Trace noise ¹ , high power, 300 Hz IFBW, Port 1 or Port 2		Spec (-10 to 55 °C)	
	Frequency	Magnitude (dB rms)	Phase (deg rms)
N991xA, N992xA, N995xA	> 300 kHz to 20 GHz ²	0.004	0.07
	> 20 to 26.5 GHz	0.007	0.14
	> 26.5 to 30 GHz	0.007	0.14
	> 30 to 50 GHz	0.008	0.22
Receiver compression		Typical	
	Frequency	Port 1 or Port 2	
N991xA, N992xA	500 MHz to 1 GHz	+10 dBm, 0.15 dB compression	
	> 1 to 26.5 GHz	+10 dBm, 0.10 dB compression	
N995xA	2 MHz to 50 GHz	+5 dBm, 0.10 dB compression	
Maximum input level		Port 1 or Port 2	
	Average CW power	DC	
N991xA, N992xA	+27 dBm, 0.5 watts	± 50 VDC	
N991xA (with option V5K)	+27 dBm, 0.5 watts	± 40 VDC	
N995xA	+25 dBm, 0.3 watts	± 40 VDC	
Immunity to interfering signals		Nominal	
		+16 dBm	

CAT and VNA measurements

CAT mode	
CAT measurements	Distance-to-fault (dB) Return loss (dB) Return loss and DTF (dB) VSWR Distance-to-fault (VSWR) Cable loss (1-port) Insertion loss (2-port) (requires option 211) Distance-to-fault (Lin) TDR (Lin rho) (requires option 215) TDR (ohm) (requires option 215) TDR & DTF (requires option 215)
Distance-to-fault (DTF) settings	
Frequency/distance	Start distance, stop distance
Sweep time	Units: meters or feet (Can also be set as Preferences)
Frequency mode	Bandpass, lowpass
CAT mode averaging	Set sweep time in seconds

¹ For CAT mode, increase trace noise by a factor of 5.7, as CAT mode IFBW is fixed at 10 kHz. Can use averaging in CAT mode to reduce trace noise or use VNA mode with 300 Hz IFBW.

² Excludes multiples of 390 kHz.

Cable and Antenna Analyzer and Vector Network Analyzer (continued)

CAT and VNA measurements (continued)

CAT mode	
Distance-to-fault	Available in CAT mode. Standard on N991xA and N995x analyzers. Option 305 on N992xA analyzers Range = velocity factor x speed of light x (number of points - 1) / frequency span x 2 Number of points auto coupled according to start and stop distance entered. Resolution = range / (number of points - 1) Transform modes: Bandpass, low-pass Window types: Maximum, medium, and minimum Alias free range indicator: On/Off Dispersion compensation for waveguide: Yes
Return loss, log magnitude	-500 to 500 dB
Log magnitude resolution	0.01 dB
VSWR	1.01 to 1000
VSWR resolution	0.01
VNA mode	
VNA Transmission/Reflection (T/R)	S11, S21 magnitude and phase (requires option 210)
VNA S-parameters	S11, S21, S22, S12 magnitude and phase (requires options 210 and 211)
Number of traces	Four traces available: Tr1, Tr2, Tr3, Tr4
Display formats	Single-trace Dual-trace split (each trace on separate graticule) Dual-trace overlay (both traces on one graticule) Three-trace split (each trace on separate graticule) Three-trace overlay (all three traces on one graticule) Quad-trace split (each trace on separate graticule) Quad-trace overlay (all four traces on one graticule)
VNA trace formats	Log magnitude, linear magnitude, VSWR, phase, Smith chart, polar, group delay, unwrapped phase, real impedance, imaginary impedance, Z magnitude
Frequency settings	Start, stop, center, span
Frequency sweep type	Linear
Sweep type trigger	Continuous, single
Sweep trigger source	Internal, external, point (point trigger applies to 1-port cal only)
Sweep trigger slope	Positive, negative
Sweep trigger delay	0 to 10 seconds
Averaging	Sweep averaging: 2 to 1000
Smoothing	Computes the moving average of adjacent data points. Smoothing aperture defines the trace width (number of points) to be averaged. Minimum aperture: 0.05% of frequency span Maximum aperture: 25% of frequency span
Scale	Autoscale, scale, reference level, reference position Autoscale: Automatically selects scale resolution and reference value to center the trace. Autoscale all: Scales all visible traces.

Cable and Antenna Analyzer and Vector Network Analyzer (continued)

CAT and VNA measurements (continued)

VNA mode	
S11, log magnitude	-500 to 500 dB
Log magnitude resolution	0.01 dB
VSWR	1.01 to 1000
VSWR resolution	0.01
Phase	-180 to +180 degrees (unwrapped phase can show larger values)
Phase resolution	0.01 degrees
Phase offset	-360 to +360 degrees
Magnitude offset	-100 to +100 dB
Trace math	Vector division or subtraction of current linear measurement values and memory data
Port extension	For both port 1 and port 2, delay settings. Port extensions apply to all measurements.
Marker formats	Default marker format is the trace format. Other formats: R + jX Z magnitude Phase Real Imaginary Mag & Phase dB Angle
General CAT / VNA modes	
Marker functions	Peak, Next Peak, Peak Left, Peak Right, Mkr→Center, Mkr→Delay, Min Search, Peak Excursion, Peak Threshold, Target, Bandwidth (BW, Q, Loss), Tracking CAT mode only: Tracking 3 peaks (CAT mode), Marker→Start distance, Marker→Stop distance
Marker table	On/Off
Marker types	Normal, delta, data trace and memory trace markers
Marker coupling	On/Off (coupling between traces)
Frequency blanking	Security level: none, high. If high, all frequency information is blanked out. An instrument preset is required to re-enable the frequency information.
Display data	Display data, memory, data and memory, or data math
Trace math	One memory trace per data trace.

Cable and Antenna Analyzer and Vector Network Analyzer (continued)

CAT and VNA mode calibrations

FieldFox analyzers offer three tiers of calibrations, thus providing users with different levels of calibration effort and accuracy.

CalReady

CalReady is the most basic calibration and is sufficient for a quick pass/fail or go/no go verification. Every FieldFox is calibrated at the factory, at test ports 1 and 2, at room temperature. CalReady can be applied either as an “enhanced response CalReady” or a “2-port CalReady.” The default setting is 2-port CalReady, so correction is applied to both ports. A user preference allows user to change the CalReady methodology to enhanced response CalReady.

A 30-minute warm-up period is recommended for a quick test. A 90-minute warm-up is necessary for more stringent test requirements.

If CalReady is the basis for most measurements, the annual cal cycle must be followed, as the CalReady calibration will be updated during the annual cal cycle.

QuickCal

QuickCal is the next level of calibration. QuickCal uses internal standards and a subset of external standards and builds on the factory-created CalReady. Users can perform QuickCal with a load or without a load. A QuickCal calibration with a load yields a more accurate measurement.

Important note: QuickCal is most accurate for DUTs with 7/16 and Type-N connectors and measurement uncertainties are provided for frequencies ≤ 18 GHz. Accuracy is reduced for DUTs with 3.5 mm (m), SMA (m), or other male coaxial connectors; performance is unspecified. QuickCal is not recommended for DUTs with 3.5 mm (f), SMA (f), or other similar female connectors. QuickCal is not applicable to waveguide.

A 60-minute warm-up period is recommended.

If QuickCal is the basis for most measurements, it is highly recommended that the annual cal cycle be followed, as QuickCal builds on CalReady and CalReady data are updated during the annual cal cycle.

Cable and Antenna Analyzer and Vector Network Analyzer (continued)

Standard calibrations

Standard calibrations are the most accurate calibrations offered in FieldFox. FieldFox's calibration engine is based on Keysight's flagship PNA calibration engine, and as such, offers many of the standard calibrations. FieldFox supports both coaxial and waveguide calibrations. The table below lists the commonly used calibrations.

A 60-minute warm-up period is recommended for standard calibrations. For ultimate in stability and accuracy, a 90-minute warm-up period is necessary

Frequency response Open response Short response Thru response With and without isolation	Simultaneous magnitude and phase correction of frequency response errors for either reflection or transmission measurements. Isolation corrects for crosstalk errors.
1-port OSL (Port 1) 1-port OSL (Port 2)	Open, short, and load Traditional 1-port calibration for reflection measurements. Corrects for directivity, source match, and frequency response errors.
SSL (for waveguide)	For waveguide calibrations, depending on the calibration kit definition, this is presented as a short, offset short and load calibration.
Enhanced response (also known as one-path, two-port) Forward enhanced response Reverse enhanced response	Corrects for frequency response and source match. Partial correction for load match for low-loss reciprocal devices.
QSOLT (2-port)	QSOLT or Quick short-open-load-thru is FieldFox's default recommended calibration for insertable devices. Full 12-term error correction. Requires fewer connections, compared to traditional SOLT (4 compared to 7). Corrects for directivity, source match, reflection frequency response, load match, and transmission frequency response.
Full 2-port (unknown thru calibration)	FieldFox's default recommended calibration for non-insertable devices. Full 12-term error correction. Beneficial for characterizing non-insertable devices such as Type-N to 3.5 mm, or female-female devices. Corrects for directivity, source match, reflection frequency response, load match, and transmission frequency response.
TRL	TRL or thru-reflect-line compensates for directivity, reflection, and transmission frequency response in both the forward and reverse directions.

** Note: FieldFox does not offer the traditional SOLT calibration. Instead, it offers the more accurate Full 2-port (unknown thru), and also QSOLT.

ECal

FieldFox supports all Keysight USB ECal modules, both standard and value-line ECals.

FieldFox's guided calibration wizard

FieldFox's calibration wizard recommends a calibration type and calibration kit based on selected parameters and connector types. Alternatively, users can select their own calibration type and calibration kit. FieldFox's calibration wizard ensures a valid calibration selection.

Cable and Antenna Analyzer and Vector Network Analyzer (continued)

Interpolation error correction

With any type of accuracy enhancement applied, interpolated mode recalculates the error coefficients when the test frequencies are changed. The number of points can be increased or decreased, and the start/stop frequencies can be changed, but the resulting frequency span must be a subset of the original calibration frequency span.

Connectors

The following connector types are included by default with the FieldFox firmware. Additional connector types can be added by adding a new calibration kit that is based on the new connector type.

Coaxial	Waveguide
Type-N 50 ohm	WR-10
Type-N 75 ohm	WR-15
7/16	WR-22
TNC	WR-28
Type-F	WR-42
7 mm	WR-62
3.5 mm	WR-75
2.4 mm	WR-90
2.92 mm	WR-112
	WR-137
	WR-187
	WR-284
	WR-650

FieldFox S-parameter measurement uncertainty charts

This data sheet includes measurement uncertainty charts for the configurations listed in the table below. Additional uncertainty charts are available in the secondary data sheet 5992-1926EN.

FieldFox model	Calibration kit	Calibration type	DUT connector	Uncertainty
N9913/4/5/6/7/8A & N9925/6/7/8A	—	QuickCal	Type-N(m)	Nominal
N9913/4/5/6/7/8A & N9925/6/7/8A	85518A or 85519A	Full 2-port calibration	Type-N	Spec
N9913/4/5/6/7/8A & N9925/6/7/8A	85054D	Full 2-port calibration	Type-N	Spec
NN9913/4/5/6/7/8A & N9925/6/7/8A	85520A or 85521A	Full 2-port calibration	3.5 mm	Spec
N9913/4/5/6/7/8A & N9925/6/7/8A	85052D	Full 2-port calibration	3.5 mm	Spec
N9950/1/2A	85056D	Full 2-port calibration	2.4 mm	Spec
N9950/1/2A	N4693D ECal	Full 2-port calibration	2.4 mm	Spec

Corrected Measurement Uncertainty

N9913/4/5/6/7/8A and N9925/6/7/8A, QuickCal, DUT: Type-N(m), Nominal¹

Power level of -15 dBm, 10 Hz IF bandwidth, no averaging, battery saver off, and 30-minute warm-up time. Includes uncertainties due to drift, noise, compression, and dynamic accuracy. Coverage factor of x1 applied to uncertainties, for ease of comparison with other industry handheld analyzers.

Transmission uncertainty (S21, S12)

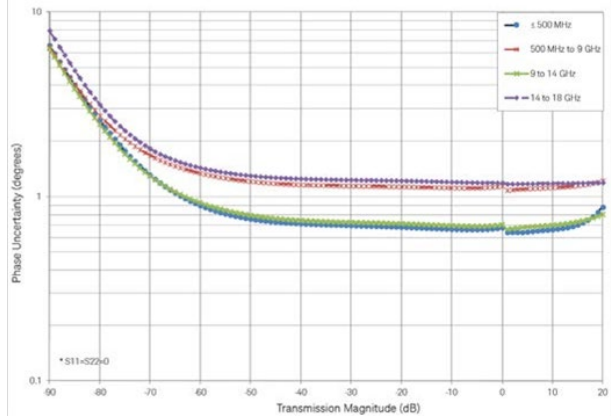
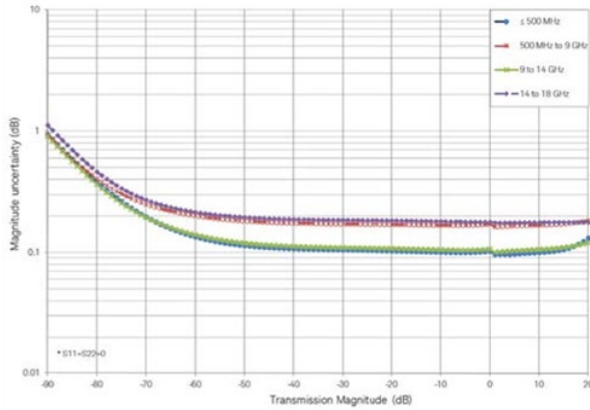

Reflection uncertainty (S11, S22)

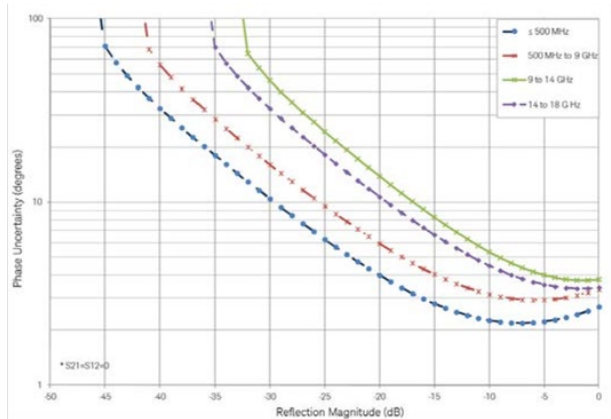
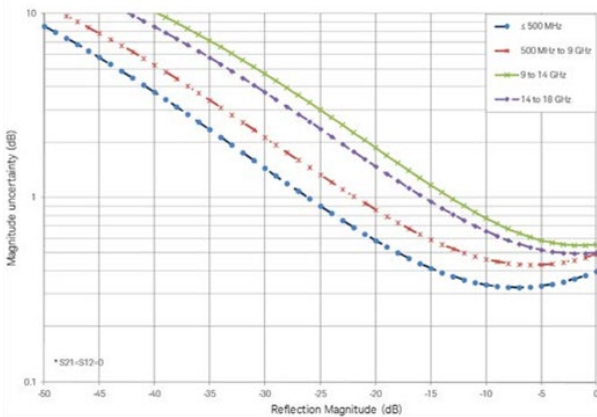

¹ Uncertainties shown based on a factory calibration using data-based calibration kits.

Corrected Measurement Uncertainty (continued)

N9913/4/5/6/7/8A and N9925/6/7/8A, 85518A or 85519A, Full 2-port Cal, DUT: Type-N, Spec

Power level of -15 dBm, 10 Hz IF bandwidth, no averaging, battery saver off, and 60-minute warm-up time. Includes uncertainties due to drift, noise, compression, and dynamic accuracy. Coverage factor of x1 applied to uncertainties, for ease of comparison with other industry handheld analyzers.

Corrected performance (dB)	0.2 to 500 MHz ¹	0.5 to 2 GHz	2 to 9 GHz	9 to 18 GHz
Directivity	44	42	35	32
Source match	37	36	33	30
Load match	37	36	33	30
Reflection tracking	± 0.050	± 0.060	± 0.070	± 0.100
Transmission tracking	± 0.050	± 0.060	± 0.070	± 0.100

Transmission uncertainty (S21, S12)

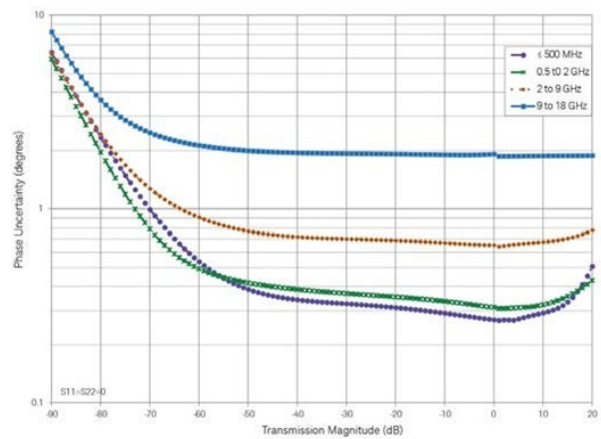
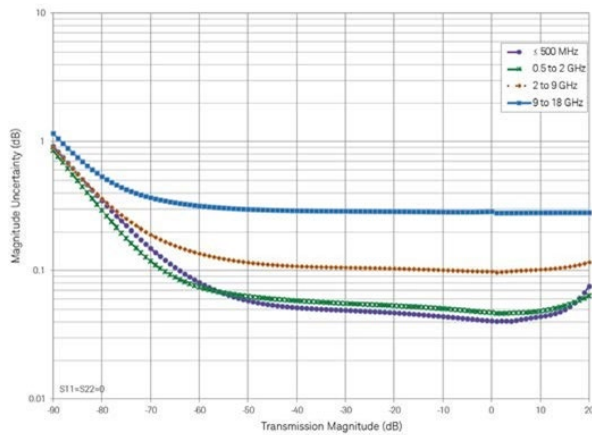

Reflection uncertainty (S11, S22)

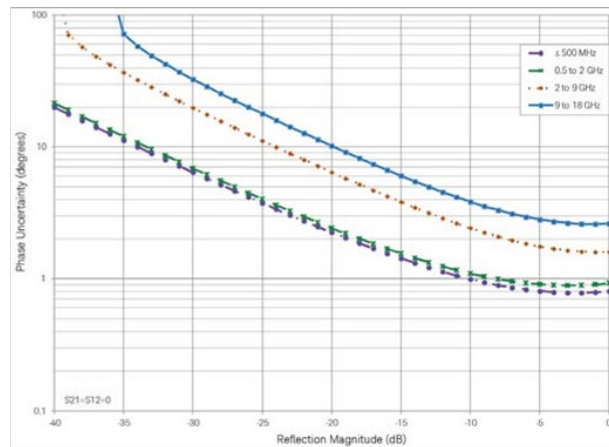
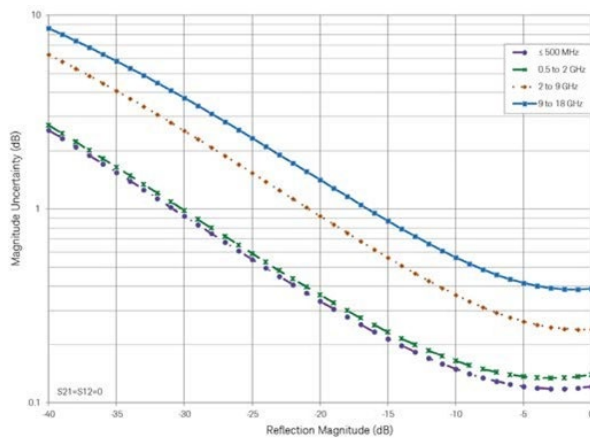

¹ Start frequency of 200 kHz applies to measurement uncertainty charts.

Corrected Measurement Uncertainty (continued)

N9913/4/5/6/7/8A and N9925/6/7/8A, 85054D, Full 2-port Cal, DUT: Type-N, Spec

Power level of -15 dBm, 10 Hz IF bandwidth, no averaging, battery saver off, and 60-minute warm-up time. Includes uncertainties due to drift, noise, compression, and dynamic accuracy. Coverage factor of x1 applied to uncertainties, for ease of comparison with other industry handheld analyzers.

Corrected performance (dB)	0.2 to 500 MHz ¹	0.5 to 2 GHz	2 to 8 GHz	8 to 18 GHz
Directivity	40	40	36	34
Source match	38	33	33	27
Load match	38	33	33	27
Reflection tracking	± 0.006	± 0.006	± 0.009	± 0.027
Transmission tracking	± 0.006	± 0.006	± 0.009	± 0.027

Transmission uncertainty (S21, S12)

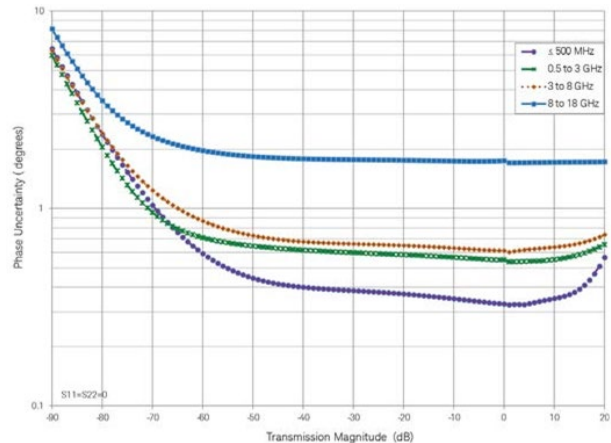
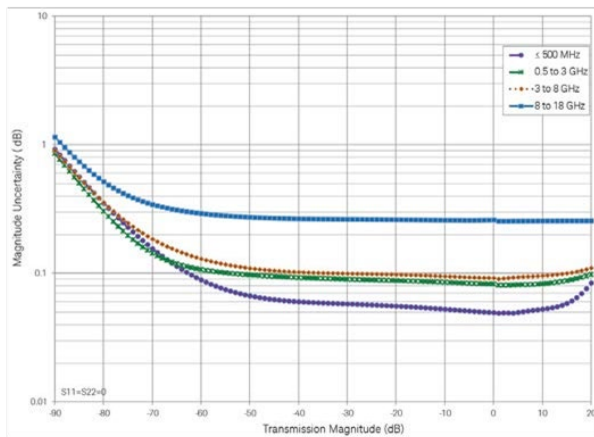

Reflection uncertainty (S11, S22)

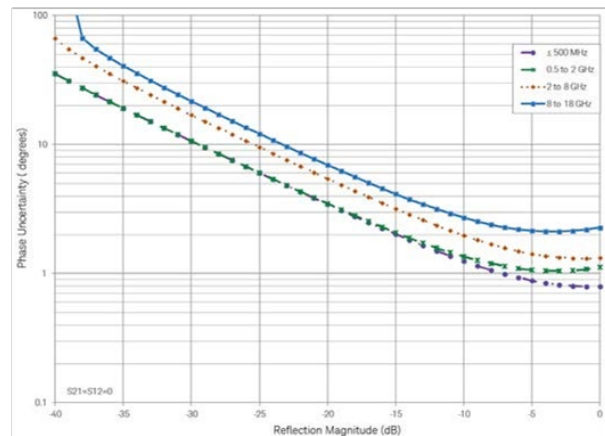
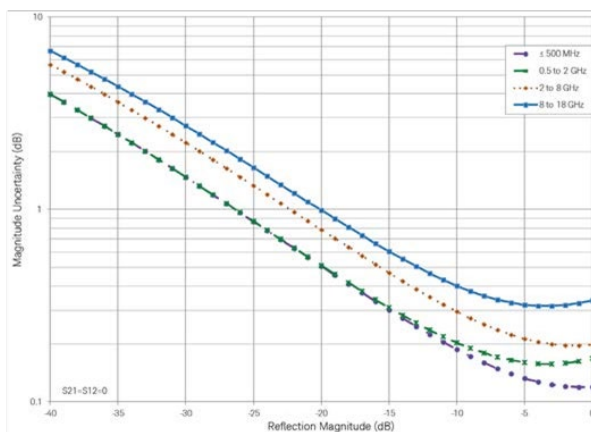

¹ Start frequency of 200 kHz applies to measurement uncertainty charts.

Corrected Measurement Uncertainty (continued)

N9913/4/5/6/7/8A and N9925/6/7/8A, 85520A or 85521A, Full 2-port Cal, DUT: 3.5 mm, Spec

Power level of -15 dBm, 10 Hz IF bandwidth, no averaging, battery saver off, and 60-minute warm-up time. Includes uncertainties due to drift, noise, compression, and dynamic accuracy. Coverage factor of x1 applied to uncertainties, for ease of comparison with other industry handheld analyzers.

Corrected performance (dB)	0.2 to 500 MHz ¹	0.5 to 9 GHz	9 to 18 GHz	18 to 26.5 GHz
Directivity	42	36	32	32
Source match	37	30	28	27
Load match	37	30	28	27
Reflection tracking	± 0.035	± 0.130	± 0.140	± 0.210
Transmission tracking	± 0.035	± 0.130	± 0.140	± 0.210

Transmission uncertainty (S21, S12)

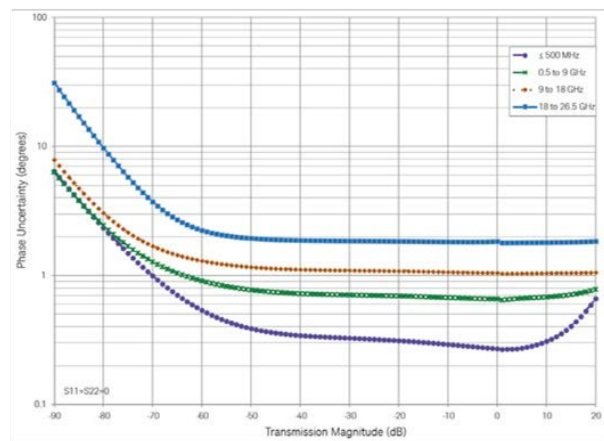
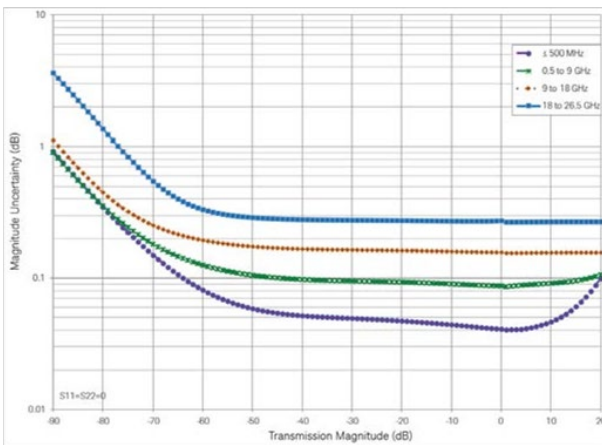

Reflection uncertainty (S11, S22)

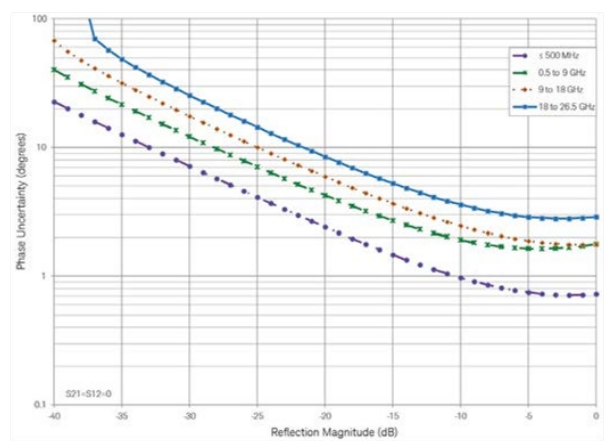
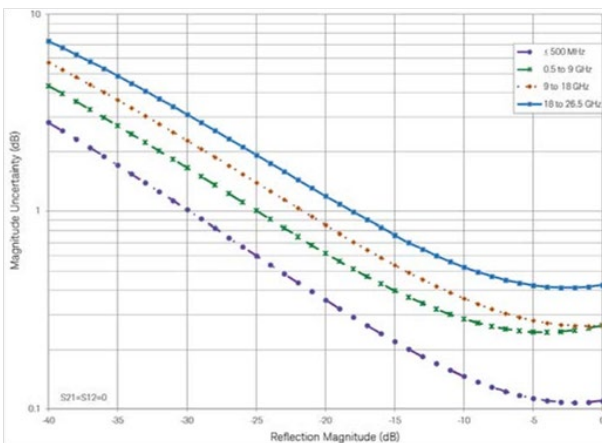

¹ Start frequency of 200 kHz applies to measurement uncertainty charts.

Corrected Measurement Uncertainty (continued)

N9913/4/5/6/7/8A and N9925/6/7/8A, 85052D, Full 2-port Cal, DUT: 3.5 mm, Spec

Power level of -15 dBm, 10 Hz IF bandwidth, no averaging, battery saver off, and 60-minute warm-up time. Includes uncertainties due to drift, noise, compression, and dynamic accuracy. Coverage factor of x1 applied to uncertainties, for ease of comparison with other industry handheld analyzers.

Corrected performance (dB)	0.2 to 500 MHz ¹	0.5 to 8 GHz	8 to 20 GHz	20 to 26.5 GHz
Directivity	42	38	36	30
Source match	37	31	28	25
Load match	37	31	28	25
Reflection tracking	± 0.005	± 0.006	± 0.009	± 0.012
Transmission tracking	± 0.005	± 0.006	± 0.009	± 0.012

Transmission uncertainty (S21, S12)

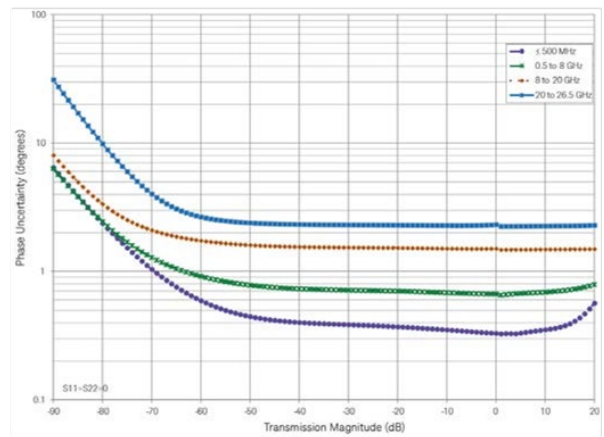
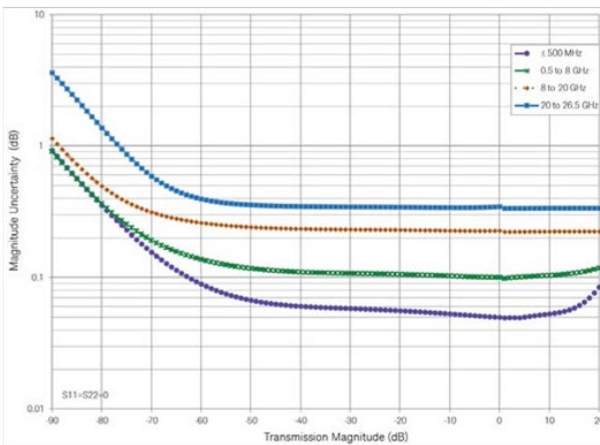

Reflection uncertainty (S11, S22)

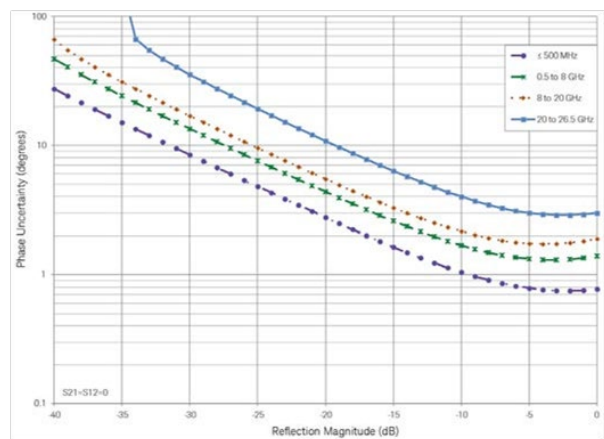
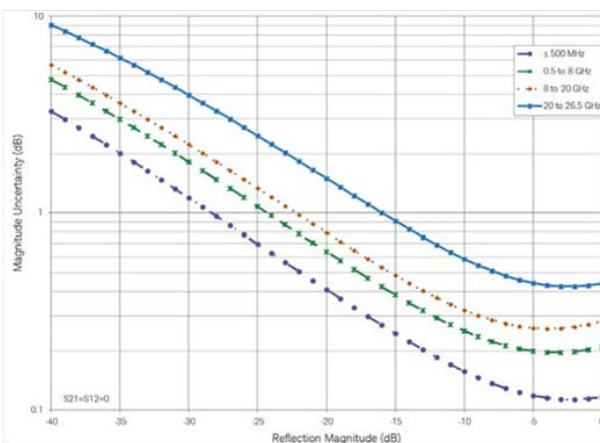

¹ Start frequency of 200 kHz applies to measurement uncertainty charts.

Corrected Measurement Uncertainty (continued)

N9950/1/2A, 85056D, Full 2-port Cal, DUT: 2.4 mm, Spec¹

Power level of -15 dBm, 10 Hz IF bandwidth, no averaging, battery saver off, and 60-minute warm-up time. Includes uncertainties due to drift, noise, compression, and dynamic accuracy. Coverage factor of x1 applied to uncertainties, for ease of comparison with other industry handheld analyzers.

Corrected performance (dB)	≤ 2 GHz	2 to 20 GHz	20 to 40 GHz	40 to 50 GHz
Directivity	42	34	26	26
Source match	39	30	23	23
Load match	39	30	23	23
Reflection tracking	± 0.002	± 0.029	± 0.080	± 0.075
Transmission tracking	± 0.002	± 0.029	± 0.080	± 0.075

Transmission uncertainty (S₂₁, S₁₂)

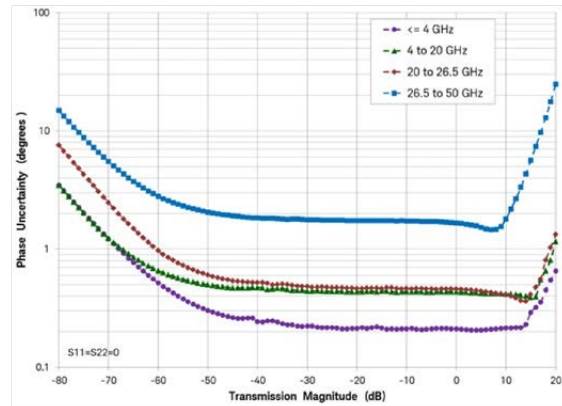
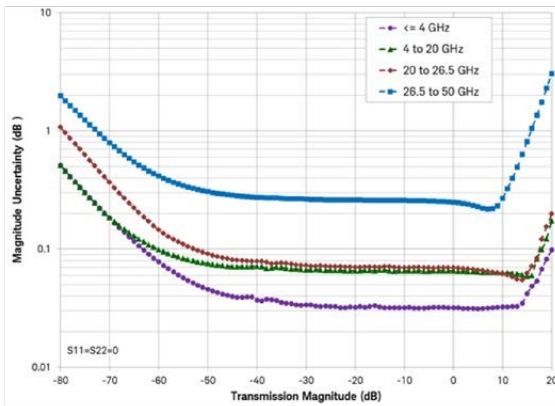

Reflection uncertainty (S₁₁, S₂₂)

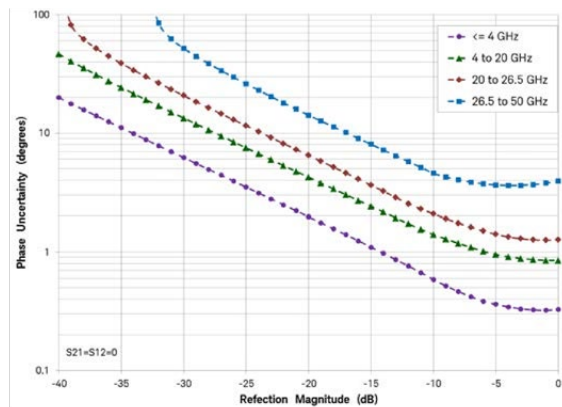
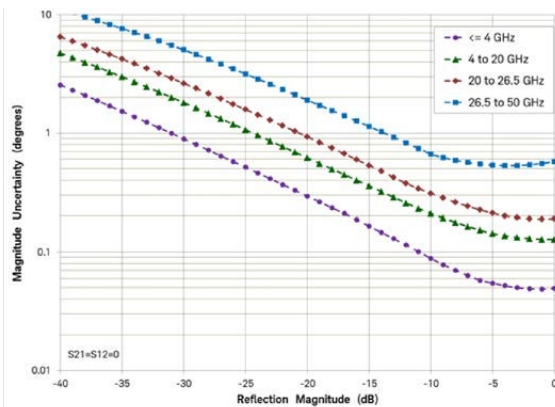

¹ Uncertainty curves shown are calculated based on ISO GUM methodology. The values in the table are provided for reference only, in accordance to legacy uncertainty methods.

Corrected Measurement Uncertainty (continued)

N9950/1/2A, N4693D ECal, Full 2-port Cal, DUT: 2.4 mm, Spec¹

Corrected performance table calculated using uncertainties with a coverage factor of 2.

Corrected performance (dB) ²	.2 to 45 MHz ³	10 MHz to 45 MHz ⁴	45 to 200 MHz	200 MHz to 2 GHz	2 to 10 GHz	10 to 20 GHz	20 to 40 GHz	40 to 50 GHz
Directivity	40	27	40	46	47	44	38	34
Source match	38	25	44	46	42	37	35	32
Load match	38	25	44	46	42	37	35	32
Reflection tracking	± 0.05	± 0.05	± 0.05	± 0.03	± 0.04	± 0.05	± 0.06	± 0.08
Transmission tracking	± 0.05	± 0.05	± 0.05	± 0.03	± 0.04	± 0.05	± 0.06	± 0.08

Uncertainty plots: power level of -15 dBm, 10 Hz IF bandwidth, no averaging, battery saver off, and 60-minute warm-up time. Includes uncertainties due to drift, noise, compression, and dynamic accuracy. Coverage factor of x1 applied to uncertainties, for ease of comparison with other industry handheld analyzers.

Transmission uncertainty (S₂₁, S₁₂)

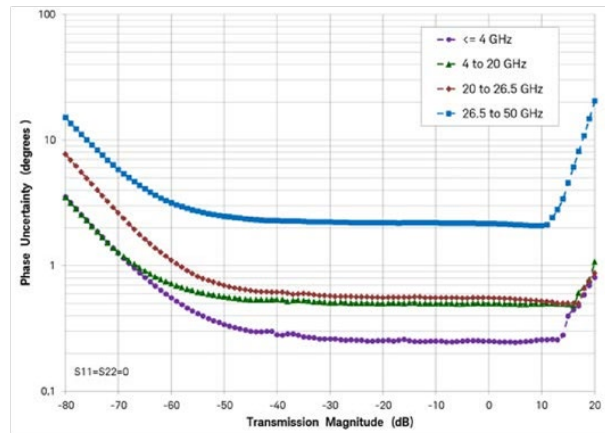
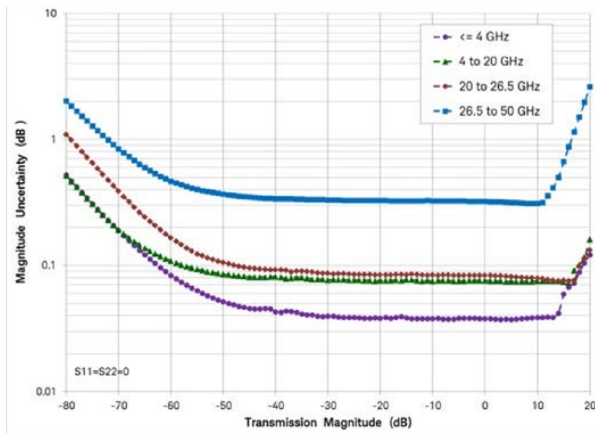

Reflection uncertainty (S₁₁, S₂₂)

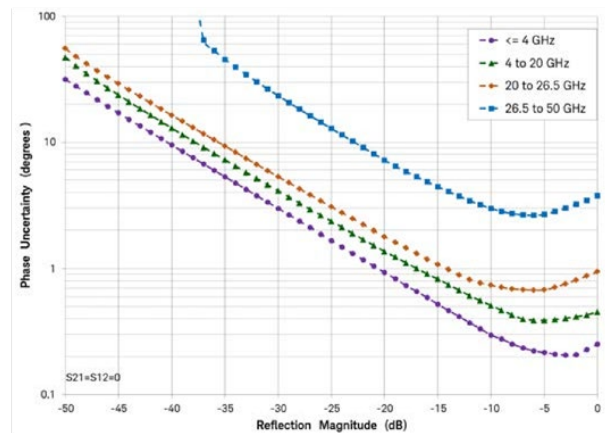
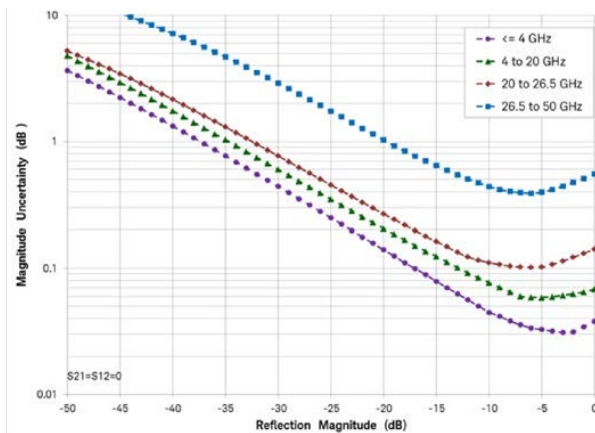

¹ Uncertainty plots generated with data from N4693B and are based on ISO GUM methodology. The values in the table are provided for reference only, in accordance to legacy uncertainty methods.

² When applied power exceeds -10 dBm, calibration results will be degraded from the performance indicated in this table.

³ For N4693D ECal Option ODC.

⁴ For N4693D ECal Option 010.

The performance listed in TDR cable measurements, VNA time domain, mixed-mode S-parameters and vector voltmeter sections applies to the capabilities available in the following models:

FieldFox RF & microwave (combination) analyzers:	N9913A, N9914A, N9915A, N9916A, N9917A, N9918A N9950A, N9951A, N9952A
--	--

FieldFox microwave vector network analyzers:	N9925A, N9926A, N9927A, N9928A
--	--------------------------------

See [FieldFox Configuration Guide](#) for option information. Many capabilities listed in this Data Sheet require options.

TDR Cable Measurements (Option 215)

The TDR cable option adds time domain reflectometry (TDR) measurements to FieldFox's CAT mode. FieldFox's TDR measurements are based on an inverse Fourier transform of the frequency-domain data. TDR measurements are useful in not only identifying the location of faults along cables, but also the nature of the fault. Resistive, inductive and capacitive faults will each have a different response. These differences help engineers and technicians trouble-shoot line faults.

Measurements: TDR (linear rho), TDR (ohm), TDR & DTF

Y-axis: linear (rho) or impedance (ohm)

X-axis: distance (meters or feet)

VNA Time Domain (Option 010)

In time-domain mode, FieldFox computes the inverse Fourier transform of the frequency-domain data to display reflection or transmission coefficients versus time.

Setup parameters	
Time	Start, stop, center, span
Gating	Start, stop, center, span, and on/off
Numbers of points, velocity vector, line loss, window shape, independent control for all four traces	
Time stimulus modes	
Low-pass step	Low-pass step is similar to a traditional time domain reflectometer (TDR) stimulus waveform. It is used to measure low-pass devices. The frequency-domain data should extend from DC (extrapolated value) to a higher value.
Low-pass impulse	Low-pass impulse response is used to measure low-pass devices.
Bandpass impulse	The bandpass impulse simulates a pulsed RF signal and is used to measure the time domain response of band-limited devices.
Windows	
The windowing function can be used to filter the frequency domain data and thereby reduce overshoot and ringing in the time domain response.	
Windows	Minimum, medium and maximum, manual entry of Kaiser Beta and impulse width.
Gating	
The gating function can be used to selectively remove reflection or transmission time domain responses. In converting back to the frequency domain, the effects of the responses outside the gate are removed. The results can be viewed with gating on and off, using two traces.	
Gate types	Notch, bandpass
Gate shapes	Maximum, wide, normal, minimum

Mixed-Mode S-Parameters (Option 212)

Mixed-mode S-parameters are also known as balanced measurements.

Measurements	
Scc11	Common mode reflection
Sdd11	Differential mode reflection
Scd11	Differential mode stimulus, common mode response
Sdc11	Common mode stimulus, differential mode response

FieldFox's mixed-mode S-parameter measurements require the use of the default factory calibration or a user 2-port calibration. So, the FieldFox analyzer must be equipped with 2-port measurement functionality to measure mixed-mode S-parameters. Mixed-mode S-parameters are an extension of the VNA capabilities.

Vector Voltmeter (VVM) (Option 308)

With vector voltmeter mode, you can characterize the difference between two measurements easily. The zeroing function allows you to create a reference signal and characterize the difference between two device measurements. The results are shown on a large display in digital format.

	Models	Frequency range
N991xA, N992xA	N9913A	30 kHz to 4 GHz
	N9914A	30 kHz to 6.5 GHz
	N9915A, N9925A	30 kHz to 9 GHz
	N9916A, N9926A	30 kHz to 14 GHz
	N9917A, N9927A	30 kHz to 18 GHz
	N9918A, N9928A	30 kHz to 26.5 GHz
N995xA	N9950A	300 kHz to 32 GHz
	N9951A	300 kHz to 44 GHz
	N9952A	300 kHz to 50 GHz
Setup parameters		
1-port cable trimming	Reflection (S11 or S22 measurement), magnitude and phase	
2-port transmission	Transmission or S21 measurement, magnitude and phase	
A/B and B/A	Ratio of two receivers or channels, magnitude and phase – Need an external signal generator for the A/B or B/A measurement	
	Frequency (one CW frequency point)	
	IF bandwidth: 10 Hz to 100 kHz or 3 Hz to 30 kHz	
	Output power: Low, high, manual	

Ratio accuracy (A/B and B/A)

Must zero before measuring DUT. Recommend using a high-quality power splitter or 6 dB attenuators to minimize uncertainty due to mismatch.

	Frequency	Nominal (dB)
N991xA, N992xA, N995xA	100 to 300 kHz ¹	± 1.0
	> 300 kHz to 1 MHz	± 0.4
	> 1 to 100 MHz	± 0.2
	> 100 to 300 MHz	± 0.4
	> 300 MHz to 1.5 GHz	± 0.6
	> 1.5 to 2 GHz	± 1.0

¹ Does not apply to N995xA models, which start at 300 kHz.

Spectrum Analyzer (Option 233 on Combination Analyzers)

The performance listed in this section applies to the spectrum analyzer capabilities available in the following models:

FieldFox RF & microwave (combination) analyzers:	N9913A, N9914A, N9915A, N9916A, N9917A, N9918A N9950A, N9951A, N9952A
FieldFox microwave spectrum analyzers:	N9935A, N9936A, N9937A, N9938A N9960A, N9961A, N9962A

See [FieldFox Configuration Guide](#) for option information. Many capabilities listed in this Data Sheet require options.

Frequency and time specifications

	Models	Frequency range ¹
N991xA, N993xA	N9913A	5 kHz to 4 GHz
	N9914A	5 kHz to 6.5 GHz
	N9915A, N9935A	5 kHz to 9 GHz
	N9916A, N9936A	5 kHz to 14 GHz
	N9917A, N9937A	5 kHz to 18 GHz
	N9918A, N9938A	5 kHz to 26.5 GHz
N995xA, N996xA	N9950A, N9960A	5 kHz to 32 GHz
	N9951A, N9961A	5 kHz to 44 GHz
	N9952A, N9962A	5 kHz to 50 GHz

Frequency reference, -10 to 55 °C

Accuracy	± 0.7 ppm (spec) + aging
	± 0.4 ppm (typical) + aging
Accuracy, when locked to GPS	± 0.01 ppm (spec)
Accuracy, when GPS antenna is disconnected	± 0.2 ppm (nominal) ²
Aging rate	± 1 ppm/yr for 20 years (spec), will not exceed ± 3.5 ppm

Frequency readout accuracy (start, stop, center, marker)

± (readout frequency x frequency reference accuracy + RBW centering + 0.5 x horizontal resolution)	Horizontal resolution = frequency span / (trace points – 1) RBW centering:
	<ul style="list-style-type: none"> • 5% x RBW, FFT mode (nominal) • 16% x RBW, step mode (nominal)

Marker frequency counter

Accuracy	± (marker frequency x frequency reference accuracy + counter resolution)
Resolution	1 Hz

¹ The spectrum analyzer is tunable to 0 Hz or DC.

² The maximum drift expected in the frequency reference applicable when the ambient temperature changes ± 5°C from the temperature when the GPS signal was last connected.

Spectrum Analyzer (Option 233 on Combination Analyzers) (continued)

Frequency and time specifications (continued)

Frequency Span	Spec	
Range	0 Hz (zero span), 10 Hz to maximum frequency range of instrument	
Resolution	1 Hz	
Accuracy	± (2 x RBW centering + horizontal resolution) for detector = Normal	
Sweep time readout	Measured value of the time required to complete a sweep from start to finish, including time to tune receiver, acquire data, and process trace.	
Trace update, nominal	N991xA, N993xA	N995xA, N996xA
Span = 20 MHz, RBW, VBW = 3 kHz	6.7 updates per second ¹	8 updates per second
Span = 100 MHz, RBW, VBW autocoupled	15.4 updates per second ²	19 updates per second
Center frequency tune and transfer ³	N991xA, N993xA ⁴	N995xA, N996xA
101 points, zero span	70 ms	69 ms
101 points, 1 MHz span	72 ms	72 ms
Sweep time, zero span	Nominal	
Range	N991xA, N993xA: 1 µs to 1000 s N995xA, N996xA: 1 µs to 6000 s	
Resolution	100 ns	
Readout	Entered value representing trace horizontal scale range	
Trigger (for zero span and FFT sweeps)		
Trigger type	Free run, external, video, RF burst, frame trigger	
Trigger slope	Positive edge, negative edge	
Trigger delay	Range: -150 ms to 10 s Resolution: 100 ns	
Auto trigger	Forces a periodic acquisition in the absence of a trigger event Range: 0 (off) to 30 s	
Trigger position (zero span)	Controls horizontal position of the pulse edge; use sweep time to zoom into pulse edge Range: 0 to 10, integer steps; 0 is left edge of graticule, 10 is right edge of graticule	
RF burst trigger	Nominal	
Dynamic range	40 dB	
Bandwidth	20 MHz	
Operating frequency range	20 MHz to maximum instrument frequency	
Sweep (trace) point range		
All spans	101, 201, 401, 601, 801, 1001 (defaults to 401); Arbitrary 2 to 20,001 settable through soft key "# Points" or SCPI	

¹ 1.2 updates per second; applicable to FieldFox units with serial number prefix ≤ MY5607/SG5607/US5607 and FieldFox units not upgraded with the fast CPU Option N9910HU-100/200/300.

² 4.1 updates per second; applicable to FieldFox units with serial number prefix ≤ MY5607/SG5607/US5607 and FieldFox units not upgraded with the fast CPU Option N9910HU-100/200/300.

³ Within full frequency range of instrument, not band dependent.

⁴ Applicable to FieldFox units with serial number prefix ≥ MY5607/SG5607/US5607 and FieldFox units that have been upgraded with the fast CPU Option N9910HU-100/200/300.

Spectrum Analyzer (Option 233 on Combination Analyzers) (continued)

Frequency and time specifications (continued)

Resolution bandwidth (RBW)	Nominal	
Range (-3 dB bandwidth)		
Zero span	10 Hz to 5 MHz	1, 3, 10 sequence
Non-zero span	1 Hz to 5 MHz	1, 1.5, 2, 3, 5, 7.5, 10 sequence < 300 kHz, 300 kHz, 1 MHz, 3 MHz, 5 MHz (Other RBWs may be set depending on settings)
Step keys change RBW in 1, 3, 10 sequence		
Selectivity (-60 dB / -3 dB)	4:1	
Bandwidth accuracy	Nominal	
Zero span	10 Hz to 1 MHz	± 5%
	3 MHz	± 10%
	5 MHz	± 15%
Non-zero span	1 Hz to 100 kHz	± 1%
	300 kHz to 1 MHz	± 5%
	3 MHz	± 10%
	5 MHz	± 15%
Video bandwidth (VBW)	1 Hz to 5 MHz	1, 1.5, 2, 3, 5, 7.5, 10 sequence

Amplitude accuracy and range specifications

Amplitude range		
Measurement range	DANL to +20 dBm	
Input attenuator range	0 to 30 dB, in 5 dB steps	
Preamplifier	Nominal	
Frequency range	Full band (100 kHz to maximum frequency of instrument)	
Gain	N991xA, N993xA	+20 dB, 100 kHz to 26.5 GHz
	N995xA, N996xA	+20 dB, 100 kHz to 7.5 GHz +15 dB, > 7.5 to 50 GHz
Max safe input level	Average CW power	DC
N991xA, N993xA	+27 dBm, 0.5 watts	± 50 VDC
N991xA(with option V5K)	+27 dBm, 0.5 watts	± 40 VDC
N995xA, N996xA	+25 dBm, 0.3 watts	± 40 VDC
Display range		
Log scale	10 divisions	
	0.01 to 100 dB/division in 0.01 dB steps	
Linear scale	10 divisions	
Scale units	dBm, dBmV, dBµV, dBmA, dBµA, W, V, A, dBµV/m, dBµA/m, dBG, dBT	

Spectrum Analyzer (continued)

Amplitude accuracy and range specifications (continued)

50 MHz absolute amplitude accuracy (dB)				
10 dB attenuation, input signal 0 to -35 dBm, peak detector, preamplifier off, 300 Hz RBW, all settings auto-coupled. No warm-up required.				
		Spec (-10 to 55°C)		Typical (-10 to 55 °C)
N991xA, N993xA		± 0.30		± 0.10
10 dB attenuation, input signal -5 to -35 dBm, peak detector, preamplifier off, 300 Hz RBW, all settings auto-coupled. No warm-up required.				
		Spec (-10 to 55°C)		Typical (-10 to 55 °C)
N995xA, N996xA		± 0.60		± 0.20
Total absolute amplitude accuracy (dB)				
10 dB attenuation, input signal -15 to -5 dBm, peak detector, preamplifier off, 300 Hz RBW, all settings auto-coupled, includes frequency response uncertainties. No warm-up required.				
N991xA, N993xA ^{1,2}	Spec (23 ± 5 °C)	Spec (-10 to 55 °C)	Typical (23 ± 5 °C)	Typical (-10 to 55 °C)
100 kHz to 18 GHz	± 0.80	± 1.00	± 0.35	± 0.50
> 18 to 26.5 GHz	± 1.00	± 1.20	± 0.50	± 0.60
Total absolute amplitude accuracy (dB)				
10 dB attenuation, input signal -15 to -5 dBm, peak detector, preamplifier off, 300 Hz RBW, all settings auto-coupled, includes frequency response uncertainties. No warm-up required.				
N995xA, N996xA ²	Spec (23 ± 5 °C)	Spec (-10 to 55 °C)	Typical (23 ± 5 °C)	Typical (-10 to 55 °C)
9 to 100 kHz	± 1.60	± 2.50	± 0.60	± 1.30
> 100 kHz to 2 MHz	± 1.30	± 1.90	± 0.60	± 0.80
> 2 to 15 MHz	± 1.00	± 1.20	± 0.30	± 0.50
> 15 MHz to 32 GHz	± 0.90	± 1.00 ³	± 0.30	± 0.50
> 32 to 40 GHz	± 1.10	± 1.60	± 0.50	± 0.70
> 40 to 43 GHz	± 1.50	± 2.20	± 0.50	± 0.70
> 43 to 50 GHz	± 1.60	± 2.90	± 0.50	± 0.90
Resolution bandwidth switching uncertainty		Nominal		
RBW < 5 MHz		0.0 dB		
For signals not at center frequency		0.7 dB peak-to-peak		

¹ 9 to 100 kHz: 0.4 dB (nominal) preamp on or off; applicable only for serial number with prefix of MY5607/SG5607/US5607 and FieldFox upgraded with Option N9910HU-100/200/300/400.

² For N991xA, N993xA, N995xA and N996xA models, for frequencies > 300 kHz, absolute amplitude accuracy specifications apply to not only preamplifier off, but also preamplifier on.

³ Increase by 0.3 dB between 18 and 32 GHz.

Spectrum Analyzer (continued)

Amplitude accuracy and range specifications (continued)

RF input VSWR		Nominal
N991xA, N993xA (10 dB attenuation)	10 MHz to 2.7 GHz	1.7 : 1
	> 2.7 to 7.5 GHz	1.5 : 1
	> 7.5 to 26.5 GHz	2.2 : 1
N995xA, N996xA (0 dB attenuation)	10 to 100 MHz	2.0 : 1
	> 100 to 500 MHz	1.7 : 1
	> 500 MHz to 17 GHz	1.5 : 1
	> 17 to 50 GHz	2.2 : 1
Reference level		
Range	-210 to +90 dBm	
Traces		
Detectors	Normal, positive peak, negative peak, sample, average (RMS)	
States	Clear/write, max hold, min hold, average, view, blank	
	Number of averages: 1 to 10,001	
Number	4: all four can be active simultaneously and in different states	
Markers		
Number of markers	6	
Type	Normal, delta, marker table	
Marker functions	Noise, band power, frequency counter	
Audio beep	Volume and tone change with signal strength	
Marker table	Display 6 markers	
Marker to →	Peak, next peak, peak left, peak right, center frequency, reference level, minimum	
	Tune frequency, for AM/FM tune and listen	
Marker properties	Peak criteria: peak excursion, peak threshold	
	Delta reference fixed: Off or On	
	Time zero fixed: Off or On	

Spectrum Analyzer (continued)

Dynamic range specifications

Displayed average noise level (DANL) - (dBm)				
Input terminated, RMS detection, log averaging, 0 dB input attenuation, reference level of -20 dBm, normalized to 1 Hz RBW, measured at non-zero frequency span				
N991xA, N993xA ¹				
Preamp off	Spec (23 ± 5 °C)	Spec (-10 to 55 °C)	Typical (23 ± 5 °C)	Typical (-10 to 55 °C)
2 MHz to 4.5 GHz ²	-137	-135	-139	-138
> 4.5 to 7 GHz	-133	-131	-136	-130
> 7 to 13 GHz	-129	-127	-132	-130
> 13 to 17 GHz	-124	-122	-126	-125
> 17 to 22 GHz	-119	-117	-122	-121
> 22 to 25 GHz	-114	-111	-117	-114
> 25 to 26.5 GHz	-110	-108	-112	-111
Preamp on	Spec (23 ± 5 °C)	Spec (-10 to 55 °C)	Typical (23 ± 5 °C)	Typical (-10 to 55 °C)
2 MHz to 4.5 GHz ²	-153	-151	-155	-154
> 4.5 to 7 GHz	-149	-147	-151	-150
> 7 to 13 GHz	-147	-145	-149	-148
> 13 to 17 GHz	-143	-141	-145	-144
> 17 to 22 GHz	-140	-139	-143	-142
> 22 to 25 GHz	-134	-132	-137	-134
> 25 to 26.5 GHz	-128	-126	-131	-129
N995xA, N996xA				
Preamp off	Spec (23 ± 5 °C)	Spec (-10 to 55 °C)	Typical (23 ± 5 °C)	Typical (-10 to 55 °C)
9 kHz to 2 MHz	-91	-91	-118	-118
> 2 MHz to 2.1 GHz	-137	-135	-143	-141
> 2.1 to 2.8 GHz	-135	-133	-142	-140
> 2.8 to 4.5 GHz	-137	-135	-143	-141
> 4.5 to 7 GHz	-134	-133	-140	-138
> 7 to 13 GHz	-134	-132	-141	-139
> 13 to 22 GHz	-132	-129	-140	-137
> 22 to 35 GHz	-130	-127	-137	-134
> 35 to 40 GHz	-122	-119	-132	-129
> 40 to 46 GHz	-119	-116	-126	-123
> 46 to 50 GHz	-117	-112	-124	-120

¹ 9 kHz to 2 MHz: -116 (nominal) preamp off, -120 (nominal) preamp on, applicable only for FieldFox units with serial number prefixes of MY5607/SG5607/US5607 and FieldFox units upgraded with Option N9910HU-100/200/300/400.

² Add 4 dB between 2.1 and 2.8 GHz.

Spectrum Analyzer (continued)

Dynamic range specifications (continued)

N995xA, N996xA				
Preamp on	Spec (23 ± 5 °C)	Spec (-10 to 55 °C)	Typical (23 ± 5 °C)	Typical (-10 to 55 °C)
9 kHz to 2 MHz	-94	-94	-131	-130
> 2 MHz to 2.1 GHz	-153	-151	-159	-158
> 2.1 to 2.8 GHz	-151	-149	-157	-155
> 2.8 to 4.5 GHz	-153	-151	-158	-156
> 4.5 to 7 GHz	-150	-149	-156	-154
> 7 to 13 GHz	-146	-144	-152	-150
> 13 to 22 GHz	-142	-139	-149	-147
> 22 to 35 GHz	-141	-139	-147	-145
> 35 to 40 GHz	-136	-132	-144	-141
> 40 to 46 GHz	-131	-128	-138	-135
> 46 to 50 GHz	-126	-123	-135	-132

Residual responses (dBm)	Nominal	
	N991xA, N993xA	N995xA, N996xA
Input terminated preamp off, 0 dB attenuation		
100 kHz to 10 MHz	-90	—
> 10 MHz to 13 GHz	-110	—
> 13 GHz to 20 GHz	-90	—
> 20 GHz to 26.5 GHz	-80	—
100 kHz to 10 MHz	—	-90
> 10 MHz to 1 GHz ¹	—	-110
> 1 GHz to 32 GHz ²	—	-100
> 32 GHz to 50 GHz	—	-95

Input related responses (dBc)	Nominal	
	N991xA, N993xA	N995xA, N996xA
-30 dBm signal at mixer input (excludes frequencies listed below)	-80	-80
f = center frequency		
< 2.6 GHz, f + 2 x 33.75 MHz	-80	-80
< 2.6 GHz, f - 2 x 866.25 MHz	-80	-80
< 2.6 GHz, f + 2 x 3.63375 GHz	-85	-90
≥ 2.6 to 7.5 GHz, f + 2 x 33.75 MHz	-80	-80
≥ 2.6 to 7.5 GHz, f + 2 x 866.25 MHz	-80	-80
≥ 2.6 to 7.5 GHz, f + 2 x 9.86625 GHz	-80	-85
≥ 7.5 to 16.3 GHz, f + 2 x 3.63375 GHz	-65	-65
≥ 16.3 to 26.5 GHz, f - 2 x 3.63375 GHz	-60	—
≥ 7.5 to 26.5 GHz, f + 2 x 33.75 MHz	-80	—
≥ 7.5 to 26.5 GHz, f - 2 x 866.25 MHz	-80	—
≥ 16.3 to 23 GHz, f - 2 x 3.63375 GHz	—	-60
≥ 23 to 32.5 GHz, f + 2 x 3.63375 GHz	—	-65
≥ 32.5 to 43 GHz, f - 2 x 3.63375 GHz	—	-55
≥ 7.5 to 50 GHz, f - 2 x 866.25 MHz	—	-80
≥ 7.5 to 50 GHz, f + 2 x 33.75 MHz	—	-80

¹ Excludes 90 MHz @ -95 dBm.

² Excludes 25.43 GHz @ -90 dBm.

Spectrum Analyzer (continued)

Dynamic range specifications (continued)

Other spurious responses (dBc)		Nominal	
	N991xA, N993xA	N995xA, N996xA	
LO related spurs	-60	-60	
Sideband	-80	-80	
Second harmonic distortion (dBc)		Nominal	
-30 dBm signal at mixer input		N991xA, N993xA	
≤ 1.3 GHz ¹	—	< -75	
> 1.3 GHz	—	< -60	
N995xA, N996xA		N995xA, N996xA	
≤ 4 GHz ¹	< -60	—	
> 4 GHz	< -80	—	
Third order intermodulation distortion (TOI) – (dBm)		Typical	
Two -15 dBm signals, 100 kHz spacing at mixer input (-10 to 55 °C)			
N991xA, N993xA		< 1 GHz, +10	
		1 to 7.5 GHz, +15	
		> 7.5 GHz, +21	
N995xA, N996xA		50 to 500 MHz, +9.5	
		> 500 MHz to 1 GHz, +13	
		> 1 to 2.4 GHz, +16	
		> 2.4 to 2.6 GHz, +12	
		> 2.6 GHz, +13	
Spur free dynamic range (dB) at 2.4 GHz 2/3 (TOI – DANL) in 1 Hz RBW		Nominal	
N991xA, N993xA		>105	
N995xA, N996xA		>104	

¹ Applies to frequencies > 15 MHz

Distortion and noise limited (10 Hz RBW) dynamic range (nominal)

Applies to N991xA and N993xA

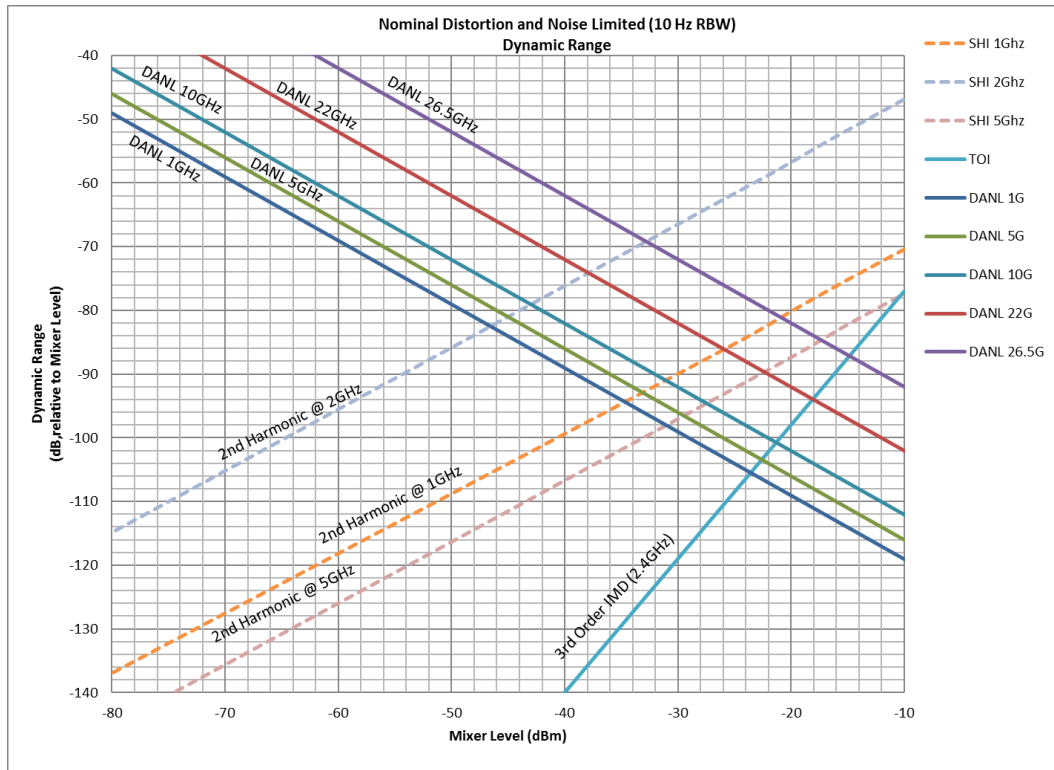

Applies to N995xA and N996xA

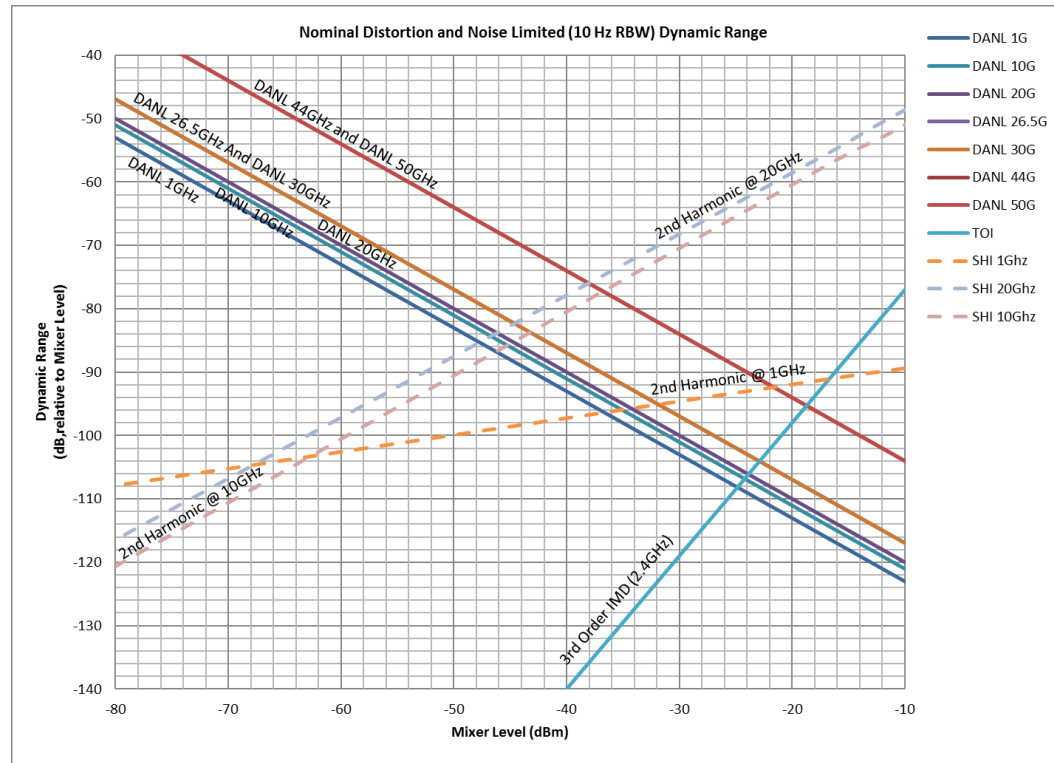

Spectrum Analyzer (continued)

SSB phase noise at 1 GHz center frequency

Phase noise (dBc/Hz)	SSB phase noise at 1 GHz (N991xA, N993xA, N995xA, N996xA)				
	Offset	Spec (23 ± 5 °C)	Spec (-10 to 55 °C)	Typical (23 ± 5 °C)	Typical (-10 to 55 °C)
	10 kHz	-106	-106	-111	-111
	30 kHz	-106	-104	-110	-108
	100 kHz	-100	-99	-105	-104
	1 MHz	-110	-110	-113	-113
	3 MHz	-119	-118	-122	-122
	5 MHz	-120	-120	-123	-123

Phase noise at different center frequencies (nominal)

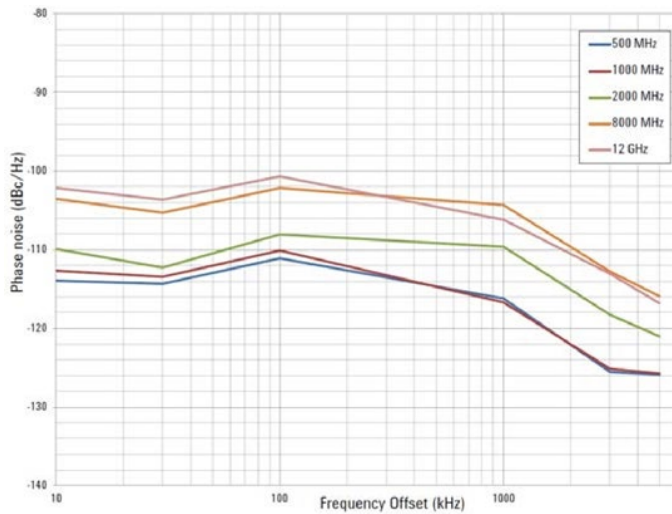

Dynamic range versus offset frequency versus RBW (nominal)

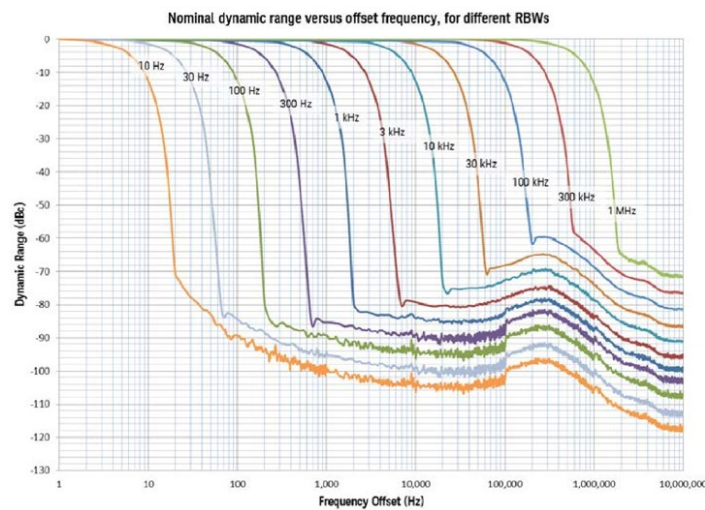

Tracking Generator or Independent Source

(See Configuration Guide for option information)

The performance listed in this section applies to the tracking generator and independent source capabilities available in the following models:

FieldFox RF & microwave (combination) analyzers:	N9913A, N9914A, N9915A, N9916A, N9917A, N9918A N9950A, N9951A, N9952A
FieldFox microwave spectrum analyzers:	N9935A, N9936A, N9937A, N9938A N9960A, N9961A, N9962A

See [FieldFox Configuration Guide](#) for option information. Many capabilities listed in this Data Sheet require options.

Note: Traditional tracking generators track the receiver frequency only. In FieldFox analyzers, the tracking generator frequency can be set to either track the receiver frequency, or act as an independent CW source.

	Models	Tracking generator or independent source frequency range
N991xA, N993xA	9913A	30 kHz to 4 GHz
	9914A	30 kHz to 6.5 GHz
	9915A, N9935A	30 kHz to 9 GHz
	9916A, N9936A	30 kHz to 14 GHz
	9917A, N9937A	30 kHz to 18 GHz
	9918A, N9938A	30 kHz to 26.5 GHz
N995xA, N996xA	9950A, N9960A	300 kHz to 32 GHz
	9951A, N9961A	300 kHz to 44 GHz
	9952A, N9962A	300 kHz to 50 GHz
Power step size		
	Power settable in 1 dB steps across power range	
Functions		
Mode	Continuous wave (CW), CW coupled, tracking (swept frequency)	
Operations	Normalization, frequency offset, spectral reversal	

Tracking Generator or Independent Source (continued)

Output power (dBm)	Frequency	Typical	Nominal
N991xA, N993xA	30 to 300 kHz	-11	—
	> 300 kHz to 2 MHz	-3	-2
	> 2 to 625 MHz	-2	-1
	> 625 MHz to 3 GHz	1	3
	> 3 to 6.5 GHz	-1	1
	> 6.5 to 9 GHz	-2	0
	> 9 to 14 GHz	-4	-2.5
	> 14 to 18 GHz	-6	-4.5
	> 18 to 23 GHz	-10	-8.5
	> 23 to 26.5 GHz	-12	-11
N995xA, N996xA	300 to 500 kHz	—	-9
	> 500 kHz to 2 MHz	-1	—
	> 2 MHz to 1 GHz	2	—
	> 1 to 6.5 GHz	2	—
	> 6.5 to 18 GHz	4	—
	> 18 to 26.5 GHz	2	—
	> 26.5 to 39 GHz	1	—
	> 39 to 44 GHz	-1	—
	> 44 to 46 GHz	-2	—
	> 46 to 50 GHz	-4	—
Dynamic range (dB)	Frequency	Typical (-10 to 55 °C) Preamp off	Nominal Preamp on
N991xA, N993xA	2 MHz to 2 GHz	97	112
	> 2 to 7 GHz	93	108
	> 7 to 11 GHz	88	103
	> 11 to 16 GHz	79	95
	> 16 to 21 GHz	71	86
	> 21 to 23 GHz	55	70
	> 23 to 25 GHz	50	65
	> 25 to 26.5 GHz	45	60
N995xA, N996xA	500 kHz to 2 MHz	79	100
	> 2 MHz to 2.1 GHz	101	115
	> 2.1 to 2.8 GHz	99	112
	> 2.8 to 4.5 GHz	101	115
	> 4.5 to 10 GHz	99	105
	> 10 to 18 GHz	88	95
	> 18 to 37 GHz	85	90
	> 37 to 40 GHz	77	82
> 40 to 43 GHz	65	80	
> 43 to 50 GHz	73	76	

Real-Time Spectrum Analyzer (RTSA) (Option 350)

The performance listed in this section applies to the real-time spectrum analyzer capabilities available in the following models:

FieldFox RF & microwave (combination) analyzers:	N9913A, N9914A, N9915A, N9916A, N9917A, N9918A N9950A, N9951A, N9952A
FieldFox microwave spectrum analyzers:	N9935A, N9936A, N9937A, N9938A N9960A, N9961A, N9962A

See [FieldFox Configuration Guide](#) for option information. Many capabilities listed in this data sheet require options.

	Models	Real-time analysis frequency range ¹	
N991xA, N993xA	N9913A	1 MHz to 4 GHz	Usable to 5 kHz
	N9914A	1 MHz to 6.5 GHz	Usable to 5 kHz
	N9915A, N9935A	1 MHz to 9 GHz	Usable to 5 kHz
	N9916A, N9936A	1 MHz to 14 GHz	Usable to 5 kHz
	N9917A, N9937A	1 MHz to 18 GHz	Usable to 5 kHz
	N9918A, N9938A	1 MHz to 26.5 GHz	Usable to 5 kHz
N995xA, N996xA	N9950A, N9960A	1 MHz to 32 GHz	Usable to 5 kHz
	N9951A, N9961A	1 MHz to 44 GHz	Usable to 5 kHz
	N9952A, N9962A	1 MHz to 50 GHz	Usable to 5 kHz

Real-time analysis		
Maximum real-time bandwidth	10 MHz	
Measurements	Density Spectrum, Spectrogram, Real-time Spectrum	
Resolution bandwidth	1 Hz to 500 kHz	Span dependent, $20 \leq \text{Span/RBW} \leq 280$. Default is 35.7 kHz
Minimum signal duration with 100% probability of intercept (POI) at full amplitude accuracy	12.2 μ s	At 10 MHz span, 500 kHz RBW
Minimum detectable signal	22 ns	Minimum detectable pulse width is the shortest pulse width of a pulsed CW signal that will display a peak amplitude that is no worse than 60 dB below the peak amplitude of a CW signal of the same power level for a 10 MHz span and auto-coupled RBW
Spurious-free dynamic range across maximum BW	63 dB	
FFT rate	120,000 FFT/s	At 10 MHz span
IF flatness (typical)	± 0.2 dB ≤ 26.5 GHz,	± 0.3 dB > 26.5 GHz
Number of display points	561	
Min. acquisition time	20 ms	At 10 MHz span
Max. acquisition time	500 ms	At 10 MHz span
Traces		
Number of traces	4: all four can be active simultaneously and in different states	
Detectors	Normal, positive peak, negative peak, sample, average (RMS)	
States	Clear/write, max. hold, min. hold, average, view, blank	

¹ Performance specified above 1 MHz. Usable down to 5 kHz.

RTSA (continued)

Markers	
Number of markers	6
Type	Normal, delta, peak
Marker →	Peak, next peak, center frequency, reference level
Trigger	
Trigger type	Free run, external, video, RF burst, periodic

I/Q Analyzer (IQA) (Option 351)

The specifications in this section apply to the I/Q analyzer capabilities available in the following models:

FieldFox RF & microwave (combination) analyzers:	N9913A, N9914A, N9915A, N9916A, N9917A, N9918A, N9950A, N9951A, N9952A
FieldFox microwave spectrum analyzers:	N9935A, N9936A, N9937A, N9938A, N9960A, N9961A, N9962A

See [FieldFox Configuration Guide](#) for option information. Many capabilities listed in this Data Sheet require options.

	Models	I/Q analysis frequency range ¹
N991x, N993x	N9913A	1 MHz to 4 GHz
	N9914A	1 MHz to 6.5 GHz
	N9915A, N9935A	1 MHz to 9 GHz
	N9916A, N9936A	1 MHz to 14 GHz
	N9917A, N9937A	1 MHz to 18 GHz
	N9918A, N9938A	1 MHz to 26.5 GHz
N995x, N996x	N9950A, N9960A	1 MHz to 32 GHz
	N9951A, N9961A	1 MHz to 44 GHz
	N9952A, N9962A	1 MHz to 50 GHz

Measurements	
Spectrum (frequency domain)	Magnitude spectrum
Waveform (time domain)	RF envelope
	I/Q waveform (Dual simultaneous top and bottom windows: I vs. time and Q vs. time)
Display (multi-domain)	
User Defined	User can set up and display up to 4 simultaneous and multi-domain measurements with any combination of the following: <ul style="list-style-type: none"> Frequency domain: Magnitude spectrum Time domain: RF envelope, Q vs. I (polar plot), Phase vs. time, Unwrapped phase vs. time, I vs. time, Q vs. time Time summary table showing I/Q capture settings: I/Q capture time, waveform start/stop, Spectrum FFT time
Measurement Setup	
I/Q capture parameters	Capture time, sample rate, sample period, capture samples

¹ Performance specified above 1 MHz. Usable down to 5 kHz.

IQA (continued)

Frequency			
Frequency span			
Resolution bandwidth (spectrum measurement)			
Range			
Overall	200 MHz to 3 MHz	1, 1.5, 2, 3, 5, 7.5, 10 sequence; arbitrary RBW settable via front panel and SCPI	
10 MHz span	90 Hz to 3 MHz	FFT window flat top (default)	
FFT window shapes	Flat Top (multiple), Uniform, Triangular, Hanning, Hamming, Gaussian (multiple), Blackman, Blackman-Harris (multiple), Kaiser Bessel (multiple), Others		
Model	N9913 /14 /15 /16 /17 /18A N9935 /36 /37 /38A Typical¹		N9950 /51 /52A N9960 /61 /62A Typical¹
Maximum bandwidth	10 MHz		10 MHz
IF flatness	Magnitude	± 0.2 dB	± 0.2 dB ≤ 26.5 GHz ± 0.3 dB > 26.5 GHz
	Phase deviation from linearity ²	2.3° peak-to-peak, 1.6° rms	2.6° peak-to-peak, 1.8° rms
	Group delay flatness (peak-to-peak) ⁴²	11 ns	
EVM (at center frequency 1 GHz)	LTE-A FDD TM3.1 (10 MHz)	0.8%	0.7%
	WCDMA TM4 (5 MHz)	0.8%	0.85%
EVM (at center frequency 2.1 GHz)	LTE-A FDD TM3.1 (10 MHz)	1%	1.1%
	WCDMA TM4 (5 MHz)	1.1%	1.2%
Spur free dynamic range (dB) at 2.4 GHz 2/3 (TOI - DANL) in 1 Hz RBW		Nominal	
N991xA, N993xA		> 105	
N995xA, N996xA		> 104	
Data acquisition (standard 10 MHz IF path)			
Total capture memory	32 MB		
Length single I/Q capture	8 bytes/sample		
Maximum length I/Q capture	4 MSa		
Sample rate (I/Q pairs)	1.25 x span, Maximum 12.5 MHz		
Length (time units)	(Captured samples - 1)/Sample rate (I/Q pairs)		
ADC resolution	14 bits		
Maximum I/Q capture time			
10 MHz IFBW	320 ms		
1 MHz IFBW	3.2 s		
100 kHz IFBW	32 s		
10 kHz IFBW	320 s		
Traces			
Number of windows and layout	1, 2 (top & bottom), 3 (one top, two bottom), or 4 (quad display)		
Number of traces	4, all four traces can be active simultaneously in all windows		
States	Clear/write, max hold, min hold, average, view, blank		

¹ These numbers were generated from room temperature results (23 °C).

² Not guaranteed below 50 MHz

IQA (continued)

Markers	
Number of markers	6 normal + delta pairs
Type	Normal, delta, peak, marker table (up to 6 markers)
Couple markers	On/off (couple markers between traces in different windows)
Marker →	Peak, next peak, center frequency, reference level
Trigger	
Trigger type	Free run, external, video, RF burst
Trigger slope	Positive edge, negative edge
Trigger delay	Range: -150 ms to 500 ms Resolution: 100 ns
Auto trigger	Forces a periodic acquisition in the absence of a trigger event Range: 0 (off) to 30 s
Data Storage	
Data types	Trace, Trace+state, picture (PNG)
I/Q capture data file types	CSV, text (TXT), SDF (compatible with 89600 VSA software), Matlab (MAT)
I/Q data formats via SCPI	Raw binary interleaved I/Q data recording, REAL32 (ASCII is default)

Noise Figure (NF) (Option 356)

The specifications in this section apply to the noise figure measurement capabilities available in the following models:

FieldFox RF & microwave (combination) analyzers:	N9913A, N9914A, N9915A, N9916A, N9917A, N9918A N9950A, N9951A, N9952A
FieldFox microwave spectrum analyzers:	N9935A, N9936A, N9937A, N9938A N9960A, N9961A, N9962A

See [FieldFox Configuration Guide](#) for option information. Many capabilities listed in this Data Sheet require options.

No warm-up is required for the instrument specifications.

	Models	Noise figure analysis frequency range
N991x, N993x	N9913A	10 MHz to 4 GHz
	N9914A	10 MHz to 6.5 GHz
	N9915A, N9935A	10 MHz to 9 GHz
	N9916A, N9936A	10 MHz to 14 GHz
	N9917A, N9937A	10 MHz to 18 GHz
	N9918A, N9938A	10 MHz to 26.5 GHz
N995x, N996x	N9950A, N9960A	10 MHz to 32 GHz
	N9951A, N9961A	10 MHz to 44 GHz
	N9952A, N9962A	10 MHz to 50 GHz

NF (continued)

Measurements			
Noise figure	Noise figure (F dB)		
Noise factor	Noise figure as a ratio (F)		
Gain	Gain (G dB)		
Noise temperature	Noise temperature in Kelvin (K)		
Y-factor	Y-factor (Y dB)		
Setup parameters		Supplemental information	
Noise source			Load ENR value(s)
DUT type	Amplifier, Downconverter, Upconverter, Multi-stage Converter		Built-in GUI wizard aids DUT measurement setup
Integration	Mode	Auto	Auto Integration: optimizes gain to avoid compression, and measurement time to achieve jitter goal
		Fixed	Fixed Integration: the time per point over which the measurement is averaged is fixed
	Jitter goal		Sets measurement jitter performance target
	Max time / point		Allows user to trade-off jitter vs. measurement time
	Jitter warning		On: displays circles on trace data if jitter goal is exceeded Off (default): disables trace circle indicators
Loss compensation	Before DUT, After DUT		User definable, compensates measurement for loss (dB) before and after DUT
Measurement bandwidth (nominal)			
Range	5 MHz (default), 2 MHz, 1 MHz, 300 kHz		
Frequency reference			
Refer to spectrum analyzer specifications			
Noise figure uncertainty calculator			Supplemental information
			Built-in Based on data from measurement
DUT	Mode	Spot	Applies single values uniformly across frequency: Input $ \Gamma $ and Output $ \Gamma $ Γ specification style: Maximum, 95th percentile, 80th percentile, Median, Mean, Fixed Γ distribution: Rayleigh, Fixed, Uniform in Circle
		Table	Applies a table of values vs. frequency: Input $ \Gamma $ and Output $ \Gamma $ Γ specification style: Maximum, 95th percentile, 80th percentile, Median, Mean, Fixed Γ distribution: Rayleigh, Fixed, Uniform in Circle
Preamplifier	Mode	Spot	Applies single values uniformly across frequency Input $ \Gamma $ and Output $ \Gamma $ Γ specification style: Maximum, 95th percentile, 80th percentile, Median, Mean, Fixed Γ distribution: Rayleigh, Fixed, Uniform in Circle
		Table	Applies a table of values vs. frequency: Input $ \Gamma $ and Output $ \Gamma $ Γ specification style: Maximum, 95th percentile, 80th percentile, Median, Mean, Fixed Γ distribution: Rayleigh, Fixed, Uniform in Circle

NF (continued)

Noise figure uncertainty calculator		Supplemental information
		Built-in Based on data from measurement
Noise source	ENR Mode	Spot Applies single values uniformly across frequency: ENR (dB), ENR Uncertainty (dB), On $ \Gamma $, Off $ \Gamma $, ENR Uncertainty Confidence (SD) Γ specification style: Maximum, 95th percentile, 80th percentile, Median, Mean, Fixed Γ distribution: Rayleigh, Fixed, Uniform in Circle
		Table Applies a table of values vs. frequency: ENR (dB), ENR Uncertainty (dB), On $ \Gamma $, Off $ \Gamma $, ENR Uncertainty Confidence (SD) Γ specification style: Maximum, 95th percentile, 80th percentile, Median, Mean, Fixed Γ distribution: Rayleigh, Fixed, Uniform in Circle
		Smart ¹ (Auto) For U183x USB smart noise sources (SNS) only. When connected with a USB SNS, FieldFox automatically downloads the ENR table data from the SNS and applies a table of values vs. frequency: ENR (dB), ENR Uncertainty (dB), On $ \Gamma $, Off $ \Gamma $, ENR Uncertainty Confidence (SD) Γ specification style: Maximum, 95th percentile, 80th percentile, Median, Mean, Fixed Γ distribution: Rayleigh, Fixed, Uniform in Circle
Uncertainty contributions	Jitter	Random independent events (fluctuations) within the bandwidth occurring during the noise measurement
	ENR	Excess noise ratio of the hot noise source connected to the DUT during the measurement
	Mismatch	Errors resulting from reflections due to impedance differences between components
	User calibration	Errors due to the optional user calibration which is performed with a defined noise standard (ENR source) connected to the input of an LNA, and fixturing/cables used in the DUT measurement, and port 2 of the FieldFox
Uncertainty coverage		User settable, uncertainty coverage can be set to 1σ (80%), 2σ (95% default), 3σ (99.5%)
Uncertainty bars		Displays vertical bars representing the calculated measurement uncertainty overlaid on the trace data
Loss compensation	Before DUT	User definable, single value, compensates measurement for insertion loss (dB) before DUT
	After DUT	User definable, single value, compensates measurement for loss (dB) after DUT
Instrument match		VSWR values are preloaded and automatically applied for instrument and U7227A/C/F or U7228A/C/F preamplifiers
Calibration options		
Receiver calibration		Uses noise source to calibrate FieldFox receiver gain bandwidth
User calibration with external U7227A/C/F or U7228A/C/F preamplifier		Optional calibration performs hot/cold measurement with external preamplifier; applies receiver and user calibrations

¹ Requires FieldFox firmware rev. A. 12.53 or later

NF (continued)

Noise figure ¹				
Model	Frequency	Internal preamplifier ON (dB)	Internal preamplifier ON + U7227/8A (dB)	Internal preamplifier ON + U7227/8C (dB)
N991xA, N993xA	10 to 100 MHz	22.5	9.0	—
	> 100 MHz to 4 GHz	22.5	8.2	9.2
	> 4 to 4.5 GHz	22.5	—	8.2
	> 4.5 to 6 GHz	26.5	—	10.6
	> 6 to 7 GHz	26.5	—	10.1
	> 7 to 13 GHz	28.5	—	11.4
	> 13 to 17 GHz	32.5	—	13.5
	> 17 to 18 GHz	34.5	—	14.4
	> 18 to 22 GHz	34.5	—	14.3
	> 22 to 25 GHz	42.5	—	20.8
	> 25 to 26.5 GHz	47.5	—	24.9

Model	Frequency	Internal preamplifier ON (dB)	Internal preamplifier ON + U7227/8C (dB)	Internal preamplifier ON + U7227/8F (dB)
N995xA, N996xA	10 to 100 MHz	18.5	—	—
	> 100 MHz to 2.1 GHz	18.5	7.6	—
	> 2.1 to 2.8 GHz	21.5	8.5	11.1
	> 2.8 to 4 GHz	20.5	8.0	9.3
	> 4 to 4.5 GHz	20.5	7.3	9.2
	> 4.5 to 6 GHz	22.5	8.1	9.7
	> 6 to 7 GHz	22.5	7.4	9.6
	> 7 to 13 GHz	26.5	9.9	11.2
	> 13 to 18 GHz	29.5	11.0	12.1
	> 18 to 22 GHz	29.5	10.2	11.5
	> 22 to 26.5 GHz	31.5	10.9	12.1
	> 26.5 to 35 GHz	31.5	—	11.5
	> 35 to 40 GHz	35.5	—	12.7
	> 40 to 44 GHz	41.5	—	16.6
> 44 to 46 GHz	41.5	—	16.1	
	> 46 to 50 GHz	44.5	—	18.1

¹ Noise figure (NF) = DANL - (-173.98 - 2.51) dB.

Nominal calculation is based on spectrum analyzer (SA) displayed average noise level (DANL) specification (dBm) stated as input terminated, RMS detection, log averaging, 0 dB input attenuation, reference level of -20 dBm, normalized to 1 Hz RBW.

Noise figure (NF) = D - (K - L), where D is the DANL (displayed average noise level) specification, K is kTB (-173.98 dBm in a 1 Hz bandwidth at 290 K), and L is 2.51 dB (the effect of log averaging used in DANL verifications).

NF (continued)

External preamplifier			
Specification	U7227/8A	U7227/8C	U7227/8F
Frequency	10 MHz to 4 GHz	100 MHz to 26.5 GHz	2 GHz to 50 GHz
Noise figure (dB)	10 MHz to 100 MHz: < 5.5 100 MHz to 4 GHz: < 5	100 MHz to 4 GHz: < 6 4 to 6 GHz: < 5 6 to 18 GHz: < 4 18 to 26.5 GHz: < 5	2 to 4 GHz: < 10 4 to 40 GHz: < 8 40 to 44 GHz: < 9 44 to 50 GHz: < 10
Gain (dB)	10 to 100 MHz: > 16 100 MHz to 4 GHz: > 0.5F ¹ + 17	100 MHz to 26.5 GHz: > 16.1 + 0.26F	2 GHz to 50 GHz: > 16.5 + 0.23F
RF connector	3.5 mm (m)	3.5 mm (m)	2.4 mm (m)
Noise source			
Model	Frequency range	ENR	
Keysight 346 noise source family			
346A	10 MHz to 18 GHz	5 to 7 dB	
346B	10 MHz to 18 GHz	14 to 16 dB	
346C	10 MHz to 26.5 GHz	12 to 17 dB	
346CK40	1 GHz to 40 GHz	3 to 14 dB	
346CK01	1 GHz to 50 GHz	7 to 20 dB	
Keysight USB smart noise source (SNS) family²			
U1832A	10 MHz to 18 GHz	4.5 to 6.5 dB	
U1832B	10 MHz to 26.5 GHz	4 to 7 dB	
U1833A	10 MHz to 18 GHz	14 to 16 dB	
U1833B	10 MHz to 26.5 GHz	12 to 17 dB	
U1832C	500 MHz to 50 GHz	3.5 to 8.5 dB	
U1833C	500 MHz to 50 GHz	10 to 21 dB	
U1833D	500 MHz to 60 GHz	6 to 21 dB	
Noise source setup		Supplemental info	
ENR Mode	Spot	Single ENR value (not frequency dependent) (default: 15 dB)	
	Table	Applies table of ENR values vs. frequency Create, save, recall, edit ENR tables File type:.ENR	
	Smart ² (Auto)	For U183x USB SNS only. When connected with a USB SNS, FieldFox updates the T cold value at beginning of every sweep, and automatically loads the ENR file from the USB SNS	
T cold	Auto (default) or Manual	Noise temperature of cold noise standard connected to DUT during the measurement	
Connector type	SMB (m)	DC bias requires accessory N9910X-713 BNC to SMB cable, for 346 noise sources only	
	USB 3.0 (Type C)	For U183x USB SNS only	
Control voltage drive level	28 ± 1 V	For 346 noise sources only, no need for U183x USB SNS	
Operating temperature	0 to 55°C		

¹ F signifies frequency in GHz

² Requires FieldFox firmware rev. A.12.53 or later

NF (continued)

Sweep	
Number of points	11 (default), 21, 51, 101, 201, 401, 601, 801, 1001
Sweep mode	Continuous or single
DUT profiles available (built-in GUI wizard aids DUT measurement setup)	
Amplifier	Includes any non-frequency-converting device
Downconverter	Frequency context can be set to RF or IF; sideband can be set to LSB, USB, DSB
Upconverter	Frequency context can be set to RF or IF; sideband can be set to LSB, USB, DSB
Multi-stage converter	Frequency context can be set to RF or IF
Display formats	
Number of traces	Two traces available
	Single-trace
Display formats	Dual-trace overlay (both traces on one graticule)
	Dual-trace split (each trace on separate top and bottom graticules)
Display data	Display data, memory, data and memory
Trace memory	One memory trace per data trace, total of 2 memory traces
Limit lines	Upper and lower for each trace
Markers	
Number of markers	6
Type	Normal, Delta, Marker Table
Marker table	Display 6 markers
Marker to →	Peak, Next Peak, Peak Left, Peak Right, Center Frequency, Reference Level, Minimum, Target
Data storage	
Data types	Trace, Trace+State, Picture (PNG), CSV

The performance listed in these sections below applies to the spectrum analyzer IF output, preamplifier, interference analyzer and spectrogram, channel scanner and 89600 VSA software capabilities available in the following models:

FieldFox RF & microwave (combination) analyzers:	N9913A, N9914A, N9915A, N9916A, N9917A, N9918A N9950A, N9951A, N9952A
FieldFox microwave spectrum analyzers:	N9935A, N9936A, N9937A, N9938A N9960A, N9961A, N9962A

See [FieldFox Configuration Guide](#) for option information. Many capabilities listed in this Data Sheet require options.

Spectrum Analyzer IF Output

	Description
Center Frequency	33.75 MHz
IF bandwidth	5 MHz (default), 25 MHz
Connector	SMB male
Conversion loss (RF input to SA output with -10 dBm input power, 0 dB attenuation, and preamp off)	
N991xA, N993xA	0 to 27 dB nominal The loss increases approximately linearly as frequency increases, with ~27 dB loss at 26.5 GHz
N995xA, N996xA	0 to 27 dB nominal The loss increases approximately linearly as frequency increases, with ~27 dB loss at 50 GHz

Preamplifier (Option 235)

	Nominal	
Frequency range	Full band (100 kHz to maximum frequency of instrument)	
Gain	N991xA, N993xA	+20 dB, 100 kHz to 26.5 GHz
	N995xA, N996xA	+20 dB, 100 kHz to 7.5 GHz +15 dB, > 7.5 to 50 GHz

Interference Analyzer and Spectrogram (Option 236)

	Description
Spectrogram display	Overlay, full screen, top, or bottom with active trace
Waterfall angle	Moderate, steep, gradual, wide angle
Markers	Time, delta time
Trace playback and recording	<ul style="list-style-type: none"> Record all spectrum analyzer measurements Playback recorded data using FieldFox Frequency mask trigger allows recording to occur upon trigger Store data internally or USB or SD card

Channel Scanner (Option 312)

	Description
Scan Mode	Range or custom list
Display Type	Bar chart vertical, bar chart horizontal, channel power, strip chart, chart overlay, scan and listen
Data logging mode	Time with geo tagging
Trace playback and recording	<ul style="list-style-type: none"> Record channel power measurement Playback recorded data using FieldFox Store data internally or USB or SD card in .csv or .kml format Data in .kml format can be exported to Google Earth

89600 VSA Software

Model		N9913 /14 /15 /16 /17 /18A N9935 /36 /37 /38A Typical ¹	N9950 /51 /52A N9960 /61 /62A Typical ¹
Maximum analysis bandwidth ²		10 MHz	10 MHz
IF flatness	Magnitude	± 0.2 dB	± 0.2 dB ≤ 26.5 GHz, ± 0.3 dB > 26.5 GHz
	Phase deviation from linearity ³	2.3° peak-to-peak, 1.6° rms	2.6° peak-to-peak, 1.8° rms
	Group delay flatness (peak-to-peak) ³		11 ns
EVM (at center frequency 1 GHz)	LTE-A FDD TM3.1 (10 MHz)	0.8%	0.7%
	WCDMA TM4 (5 MHz)	0.8%	0.85%
EVM (at center frequency 2.1 GHz)	LTE-A FDD TM3.1 (10 MHz)	1%	1%
	WCDMA TM4 (5 MHz)	1.1%	1.2%

¹ These numbers were generated from the room temperature results (23° C).

² Analysis bandwidth is the instantaneous bandwidth available around a center frequency over which the input signal can be digitized for further analysis or processing in the time, frequency, or modulation domain.

³ Not guaranteed below 50 MHz.

Over-the-Air (OTA) LTE FDD/TDD (Option 370/371)

The performance listed in this section applies to the OTA analyzer capabilities available in the following models:

FieldFox RF & microwave (combination) analyzers:	N9913A, N9914A, N9915A, N9916A, N9917A, N9918A N9950A, N9951A, N9952A
FieldFox microwave spectrum analyzers:	N9935A, N9936A, N9937A, N9938A N9960A, N9961A, N9962A

See [FieldFox Configuration Guide](#) for option information. Many capabilities listed in this Data Sheet require options.

	Models	OTA analysis frequency range ¹
N991x, N993x	N9913A	1 MHz to 4 GHz
	N9914A	1 MHz to 6.5 GHz
	N9915A, N9935A	1 MHz to 9 GHz
	N9916A, N9936A	1 MHz to 14 GHz
	N9917A, N9937A	1 MHz to 18 GHz
	N9918A, N9938A	1 MHz to 26.5 GHz
N995x, N996x	N9950A, N9960A	1 MHz to 32 GHz
	N9951A, N9961A	1 MHz to 44 GHz
	N9952A, N9962A	1 MHz to 50 GHz

Measurements²

LTE FDD/TDD Over-the-Air (OTA)

Cell scan results	Center frequency PCI (Physical Cell Identifier) (C/S/G) RSRP (Reference Signal Received Power) (dBm) RSRQ (Reference Signal Received Quality) (dB) RSSI (Reference Signal Strength Indicator) (dBm) PSS (Primary Synchronization Signal) (dBm) SSS (Secondary Synchronization Signal) (dBm) SINR (Signal to Interference & Noise Ratio) (dB) Freq Err (Frequency Error) (Hz)
Data formats	User can setup and display 1, 2, 3 or 4 simultaneous measurements of key performance indicators (KPI's) for any component carrier (CC0 through CC4), up to 5 carriers, in any combination of the following:
Table	Cell scan numeric results (for up to 6 cell sites (ID's) including Cell ID (C/S/G), RSRP, RSRQ, RSSI, PSS, SSS, SINR, Freq Err
Bar chart	Vertical power bar graph of selectable cell scan results for up to 6 cell sites with adjustable color "heat" amplitude scale
Spectrum	Magnitude spectrum frequency domain (fixed span)
Strip chart	Magnitude of selectable cell scan results graphed over time
Signal bandwidth	Up to 10 MHz

¹ Performance specified above 1 MHz. Usable down to 5 kHz.

² For center frequency signals above 1 GHz, the built-in GPS receiver (Option 307) is highly recommended or locking to any 10 MHz frequency reference. When locked to GPS as the frequency reference, this provides accuracy of ± 0.01 ppm (spec).

OTA LTE FDD/TDD (continued)

Setup parameters	
Component carrier	CC0 to CC4
Channel table	Sets frequency based on band and channel
Favorites list	Save up to 6 favorite cellular bands/channels
Window configuration	Any combination of 1, 2, 3, or all 4 windows can be displayed simultaneously; 1, 2 (top & bottom), 3 (one top, two bottom), or 4 (quad display)
Trigger	
Trigger type	Free run, external
Trigger slope	Positive edge, negative edge
Trigger delay	Range: -150 ms to 500 ms
Auto trigger	Forces a periodic acquisition in the absence of a trigger event Range: 0 (off) to 30 s
Record / Playback	
Data logging	Record, recall and playback data for all component carrier(s)
Record settings	Meas Interval, Interval type (time or distance), time interval, distance interval
Supported file types	CSV, KML
Saving data	Save/recall recorded data logs to/from internal memory or external USB stick or SD card

Over-the-Air (OTA) 5GTF (Option 377)

The performance listed in this section applies to the OTA analyzer capabilities available in the following models:

FieldFox RF & microwave (combination) analyzers:	N9913A, N9914A, N9915A, N9916A, N9917A, N9918A N9950A, N9951A, N9952A
FieldFox microwave spectrum analyzers:	N9935A, N9936A, N9937A, N9938A N9960A, N9961A, N9962A

See [FieldFox Configuration Guide](#) for option information. Many capabilities listed in this Data Sheet require options.

	Models	OTA analysis frequency range ¹
N991x, N993x	N9913A	1 MHz to 4 GHz
	N9914A	1 MHz to 6.5 GHz
	N9915A, N9935A	1 MHz to 9 GHz
	N9916A, N9936A	1 MHz to 14 GHz
	N9917A, N9937A	1 MHz to 18 GHz
	N9918A, N9938A	1 MHz to 26.5 GHz
N995x, N996x	N9950A, N9960A	1 MHz to 32 GHz
	N9951A, N9961A	1 MHz to 44 GHz
	N9952A, N9962A	1 MHz to 50 GHz

¹ Performance specified above 1 MHz. Usable down to 5 kHz.

OTA 5GTF (continued)

Measurements¹	
5GTF Over-the-Air (OTA)	
Cell scan results	Center frequency PCI (Physical Cell Identifier) Power (Channel Power) (dBm) PSS (Primary Synchronization Signal) (dBm) SSS (Secondary Synchronization Signal) (dBm) Sync Corr (Sync Correlation) (%)
Data formats	User can setup and display 1, 2, 3 or 4 simultaneous measurements of key performance indicators (KPI's) for any component carrier (CC0 through CC7), up to 8 carriers, in any combination of the following:
Table	Cell scan numeric results (for up to 6 cell sites (ID's) including Cell ID, Channel Power, PSS, SSS, Sync Corr
Bar chart	Vertical power bar graph of selectable cell scan results for up to 8 cell sites with adjustable color "heat" amplitude scale
Spectrum	Magnitude spectrum frequency domain (fixed span)
Strip chart	Magnitude of selectable cell scan results graphed over time
Signal bandwidth	Up to 10 MHz
Setup parameters	
Component carrier	CC0 to CC7
Channel table	Sets frequency based on band and channel
Window configuration	Any combination of 1, 2, 3, or all 4 windows can be displayed simultaneously; 1, 2 (top & bottom), 3 (one top, two bottom), or 4 (quad display)
Trigger	
Trigger type	Free run, external
Trigger slope	Positive edge, negative edge
Trigger delay	Range: -150 ms to 500 ms
Auto trigger	Forces a periodic acquisition in the absence of a trigger event Range: 0 (off) to 30 s
Record / Playback	
Data logging	Record, recall and playback data for all component carrier(s)
Record settings	Meas Interval, Interval type (time or distance), time interval, distance interval
Supported file types	CSV, KML
Saving data	Save/recall recorded data logs to/from internal memory or external USB stick or SD card

¹ For center frequency signals above 1 GHz, the built-in GPS receiver (Option 307) is highly recommended or locking to any 10 MHz frequency reference. When locked to GPS as the frequency reference, this provides accuracy of ± 0.01 ppm (spec).

Indoor and Outdoor Mapping (Option 352)

The performance listed in this section applies to the indoor and outdoor mapping capabilities available in the following models:

FieldFox RF & microwave (combination) analyzers:	N9913B, N9914B, N9915B, N9916B, N9917B, N9918B
FieldFox RF & microwave spectrum analyzers:	N9933B, N9934B, N9935B, N9936B, N9937B, N9938B

See [FieldFox Configuration Guide](#) for option information. Many capabilities listed in this Data Sheet require options.

Option 352 adds indoor and outdoor mapping capability to FieldFox analyzers, so that FieldFox can import maps from OpenStreetMap (OSM) for data collection and data plotting to the map directly on the FieldFox instrument display. The FieldFox indoor and outdoor mapping feature resides at the System level and the mapping capability can be enabled within the following modes:

- Channel Scanner (Option 312)
- Phased Array Antenna Support (Option 360)
- Over-the-Air (OTA) LTE FDD (Option 370)
- Over-the-Air (OTA) 5GTF (Option 377)

Indoor and outdoor mapping (Option 352) requirements:

- Spectrum analyzer mode (Option 233 on N991xB, default mode on N993xB)
- GPS receiver (Option 307), required for outdoor mapping

OSM maps can be saved to the FieldFox internal memory, SD card or USB drive. This can be done via a direct wired LAN connection or OSM maps can be downloaded and saved to FieldFox using the [FieldFox Map Support Tool](#).

	Description
Map coordinates	Latitude, longitude
Map zoom levels	4 to 17
Map icons	Flag, point, line
Map labels	On, Off
Map panorama	North, South, East, West
Data logging	Record, recall and playback
Indoor map file type	PNG

Using a direct wired LAN connection, FieldFox will automatically access OSM once location coordinates (latitude and longitude) and zoom levels are entered the Map Explorer menu. If using the FieldFox Map Support Tool, OSM map files can be downloaded to a .zip file and imported to FieldFox internal memory. If the FieldFox GPS receiver is enabled and OSM maps have been previously saved to FieldFox with those GPS coordinates, FieldFox can automatically load the corresponding map to match the GPS coordinates.

EMF Measurements (Option 358)

	Description
Supported antenna	AGOS Advanced Technologies, Triaxial Isotropic Antenna Model: SDIA-6000 Frequency coverage: 30 MHz to 6 GHz
Supported operating mode	Spectrum analyzer (Channel Power measurement only)
Antenna axis	Average all (Isotropic), X-axis, Y-axis, Z-axis
Units	Spectrum analyzer mode: dBuV/m, dBm/m ² , V/m, Watt/cm ² , W/m ² , dBμA/m, DBG, dBpT Over-the-Air (OTA) 5G NR mode: V/m, dBμV/m
Measurement time	Sweep time acquisition control can be set from 1 to 5000
Data logging	Record, recall and playback data
Supported file types	Spectrum analyzer mode: CSV Over-the-Air (OTA) 5G NR mode: CSV, KML
Saving data	Save/recall recorded data logs to/from internal memory or external USB or SD card

AM/FM Analog demodulation, Tune and Listen (Option 355)

The performance listed in this section applies to the AM/FM analog demodulation, tune and listen capabilities available in the following models:

FieldFox RF & microwave (combination) analyzers:	N9913A, N9914A, N9915A, N9916A, N9917A, N9918A N9950A, N9951A, N9952A
FieldFox microwave spectrum analyzers:	N9935A, N9936A, N9937A, N9938A N9960A, N9961A, N9962A

See [FieldFox Configuration Guide](#) for option information. Many capabilities listed in this Data Sheet require options.

	Description
Display type	RF spectrum view, demodulated waveform, including peak+ and peak- traces
Audio demodulation type	AM, FM narrow, FM wide, listen to the tones using FieldFox's built-in speaker or headphones
Audio bandwidth	16 kHz
Measurement type	RF carrier power (dBm), RF carrier frequency (Hz), modulation rate (Hz), SINAD (dB), THD (%)
Receiver IF bandwidth	Nominal
AM	35 kHz
FM narrow	12 kHz
FM wide	150 kHz
Listen time range	0 to 100 seconds
AM & FM metrics	Nominal
SINAD	2.5 dB to 65 dB
THD	0 to 75%
AM measurements	Nominal
Maximum modulation rate	5 kHz, demod sweep time: 50 μ s to 50 ms
Depth	(peak-to-peak/2) (%), \pm peak depth (%)
Depth accuracy	\pm 2%
Depth range	Modulation: 0.1 % to 99%
FM measurements	Nominal
Maximum modulation rate	5 kHz, demod sweep time: 50 μ s to 50 ms
Frequency deviation	(Hz), \pm peak deviation (Hz)
Maximum deviation	5 MHz

Radio standards

With a radio standard applied, pre-defined frequency bands, channel numbers or uplink / downlink selections can be used instead of manual frequency entry. The pre-defined FieldFox radio standards include bands such as W-CDMA, LTE, and GSM. Alternately, users can create custom standards and import them into FieldFox analyzers.

Spectrum Analyzer Time Gating (Option 238)

The performance listed in this section applies to the spectrum analyzer time gating capabilities available in the following models:

FieldFox RF & microwave (combination) analyzers:	N9913A, N9914A, N9915A, N9916A, N9917A, N9918A N9950A, N9951A, N9952A
FieldFox microwave spectrum analyzers:	N9935A, N9936A, N9937A, N9938A N9960A, N9961A, N9962A

See [FieldFox Configuration Guide](#) for option information. Many capabilities listed in this Data Sheet require options.

With time gating, you can measure the spectrum of a periodic signal during a specified time interval. Pulsed-RF signals are an example of a periodic signal that can be measured with time gating. For example, you can measure the pulse during the on period, not the transition or the off period. Or you can exclude interfering signals such as a periodic transient. Time gating allows you to view spectral components that would otherwise be hidden. FieldFox's time gating method is a Gated FFT.

	Description
Gate method	Gated FFT
Span range	Any span
RBW range	1 Hz to 300 kHz (derived from gate width)
Gate delay range	-150 ms to 10 s
Gate width (length) range	6 μ s to 1.8 s
Gate sources	External, RF burst, Video

Reflection Measurements (RL, VSWR) (Option 320, applicable to SA only models)

The performance listed in this section applies to the reflection measurements capabilities available in the following models:

FieldFox microwave spectrum analyzers:	N9935A, N9936A, N9937A, N9938A ¹ N9960A, N9961A, N9962A
--	---

See [FieldFox Configuration Guide](#) for option information. Many capabilities listed in this Data Sheet require options.

	Models	Reflection Measurements
N993xA	N9935A	30 kHz to 9 GHz
	N9936A	30 kHz to 14 GHz
	N9937A	30 kHz to 18 GHz
	N9938A ¹	30 kHz to 26.5 GHz
N996xA	N9960A	300 kHz to 32 GHz
	N9961A	300 kHz to 44 GHz
	N9962A	300 kHz to 50 GHz

Measurements

Return loss, VSWR normalization using data/memory

¹ Reflection measurements in N9938A specifically require 3.5 mm (m) test ports instead of the standard Type-N (f).

Extended Range Transmission Analysis (ERTA) (Option 209)

ERTA specifications apply to the following FieldFox models. The RF & microwave analyzers must be equipped with the spectrum analyzer option.

FieldFox RF & microwave (combination) analyzers:	N9913A, N9914A, N9915A, N9916A, N9917A, N9918A N9950A, N9951A, N9952A
FieldFox microwave spectrum analyzers:	N9935A, N9936A, N9937A, N9938A N9960A, N9961A, N9962A

ERTA operation requires two FieldFox units, each one configured with specific options, and certain accessories. See [FieldFox Configuration Guide](#) for option information. Many capabilities listed in this Data Sheet require options.

System description

ERTA can be used to measure the scalar transmission gain or loss of an RF system. It is useful when measuring long lossy cables where the two ends cannot easily be brought together, such as those bolted in on ships or aircrafts. It is also useful in measuring the insertion loss of waveguide systems, or using the frequency-offset feature, devices such as mixers and converters.

ERTA measurements are based on two FieldFox units; one at each end of the measured DUT. One FieldFox is the source and reference receiver (R), while the other is the measurement receiver (B). The two FieldFox units are synchronized using hardware triggering. By taking advantage of FieldFox's InstAlign technique, ERTA can be used to make accurate gain or loss measurements.

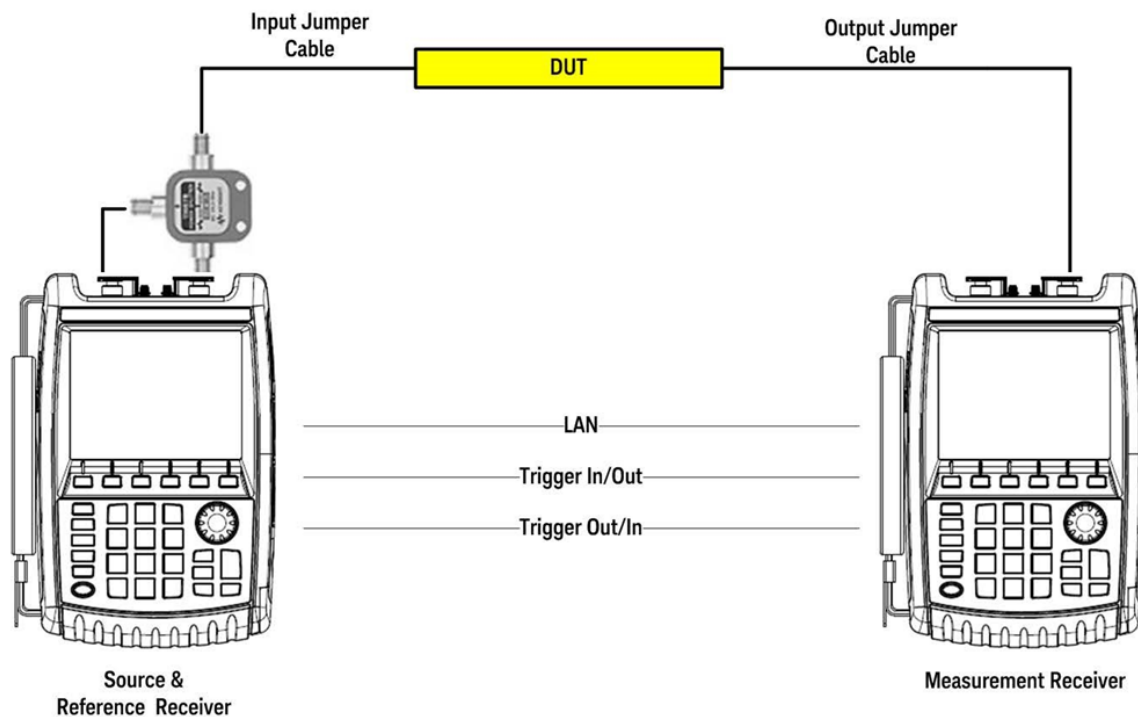

ERTA (continued)

Frequency specifications

The ERTA frequency range is limited by each individual analyzer's frequency range.

	Models	Reflection measurements	Receiver frequency range¹
N991xA, N993xA	N9913A	30 kHz to 4 GHz	100 kHz to 4 GHz
	N9914A	30 kHz to 6.5 GHz	100 kHz to 6.5 GHz
	N9915A, N9935A	30 kHz to 9 GHz	100 kHz to 9 GHz
	N9916A, N9936A	30 kHz to 14 GHz	100 kHz to 14 GHz
	N9917A, N9937A	30 kHz to 18 GHz	100 kHz to 18 GHz
	N9918A, N9938A	30 kHz to 26.5 GHz	100 kHz to 26.5 GHz
N995xA, N996xA	N9950A, N9960A	300 kHz to 32 GHz	300 kHz to 32 GHz
	N9951A, N9961A	300 kHz to 44 GHz	300 kHz to 44 GHz
	N9952A, N9962A	300 kHz to 50 GHz	300 kHz to 50 GHz

Frequency reference

Refer to the frequency accuracy specifications.

Source output power

Refer to the test port output power typical data.

Frequency setup parameters

Receiver frequency	Center/span or start/stop (standard spectrum analyzer settings) Reverse receiver sweep direction (default direction is forward, but can be set to reverse)
Source frequency [Remote]	[Tracking] – FieldFox source tracks the receiver by default. The frequencies are identical. [CW] – FieldFox's source can be set to a CW frequency independent of FieldFox's receiver frequency. FieldFox's source is at a single CW frequency; FieldFox's receiver is swept. [Coupled CW] – FieldFox's source CW frequency is auto-coupled to FieldFox's receiver [Center Frequency] setting.

Frequency-offset capability

This feature allows the FieldFox's source frequency to be offset from FieldFox's receiver frequency. The offset frequency can be negative, zero, or positive. The frequency-offset capability is useful when characterizing the scalar transmission response of devices such as mixers and converters.

¹ The receiver (spectrum analyzer) is usable to 5 kHz, though only specified to 100 kHz or 300 kHz.

ERTA (continued)

Frequency specifications (continued)

Frequency-offset setup parameters	
Receiver frequency	Center/span or start/stop (standard spectrum analyzer settings) Reverse receiver sweep direction (default direction is forward, but can be set to reverse)
Frequency tracking offset	On/Off Offset values: 0, > 0, < 0
Receiver sweep direction	Reversal: Off Default setting Both source and receiver sweep in the forward direction. Receiver stop frequency > Receiver start frequency Source frequency = Offset + Receiver frequency Reversal: On Source and receiver sweep in opposite directions. Source frequency = Offset – Receiver frequency Offset > receiver frequency

Dynamic range and maximum attenuation

Dynamic range is the difference between the maximum output power available from FieldFox's source and the noise floor of the second FieldFox, while ensuring that neither FieldFox's ADC goes into over-range. Dynamic range also accounts for the loss of the power splitter. Dynamic range is applicable when testing devices such as filters, where there is low loss in the passband, and significant loss in the stopband, and both passband and stopband need to be on the display at the same time (same sweep).

Maximum attenuation is the difference between maximum output power available from FieldFox's source and the noise floor of FieldFox. It also accounts for the loss of power splitter. Maximum attenuation is applicable when testing devices such as cables, which have relatively uniform loss over the swept frequency range.

The values shown are based on the recommended minimum RBW of 3 kHz when the frequency references are locked via GPS, and 300 kHz when the frequency references are unlocked. Locking the frequency references to GPS allows for greater frequency accuracy of the FieldFox units and use of a narrower RBW, which in turn results in a lower DANL, and hence a wider measurement range. When the GPS signals cannot be present at all times, the GPS hold-over mode can be used.

ERTA (continued)

Dynamic range and maximum attenuation (continued)

Dynamic range (dB)		Typical			
N991xA, N993xA	Preamp off	Preamp on	Preamp off	Preamp on	
	Frequency references locked to GPS, RBW 3 kHz	Frequency references locked to GPS, RBW 3 kHz	Frequency references unlocked, RBW 300 kHz	Frequency references unlocked, RBW 300 kHz	
> 2 MHz ¹ to 6 GHz	88	83	68	63	
> 6 to 13 GHz	86	83	66	63	
> 13 to 22 GHz	70	86	50	66	
> 22 to 25 GHz	63	83	43	63	
> 25 to 26.5 GHz	58	77	38	57	

Maximum attenuation (dB)		Typical			
N991xA, N993xA	Preamp off	Preamp on	Preamp off	Preamp on	
	Frequency references locked to GPS, RBW 3 kHz	Frequency references locked to GPS, RBW 3 kHz	Frequency references unlocked, RBW 300 kHz	Frequency references unlocked, RBW 300 kHz	
> 2 MHz to 6 GHz	93	108	73	88	
> 6 to 13 GHz	86	103	66	83	
> 13 to 22 GHz	70	91	50	71	
> 22 to 25 GHz	63	83	43	63	
> 25 to 26.5 GHz	58	77	38	57	

Dynamic range (dB)		Typical			
N995xA, N996xA	Preamp off	Preamp on	Preamp off	Preamp on	
	Frequency references locked to GPS, RBW 3 kHz	Frequency references locked to GPS, RBW 3 kHz	Frequency references unlocked, RBW 300 kHz	Frequency references unlocked, RBW 300 kHz	
> 2 to 5 MHz	83	87	62	58	
> 5 MHz to 11 GHz	93	97	69	68	
> 11 to 19 GHz	95	96	71	70	
> 19 to 22 GHz	93	94	69	68	
> 22 to 40 GHz	88	90	63	65	
> 40 to 43 GHz	82	89	57	64	
> 43 to 46 GHz	81	93	56	68	
> 46 to 50 GHz	77	88	52	63	

Maximum attenuation (dB)		Typical			
N995xA, N996xA	Preamp off	Preamp on	Preamp off	Preamp on	
	Frequency references locked to GPS, RBW 3 kHz	Frequency references locked to GPS, RBW 3 kHz	Frequency references unlocked, RBW 300 kHz	Frequency references unlocked, RBW 300 kHz	
> 2 MHz to 13 GHz	100	113	74	88	
> 13 to 18 GHz	101	110	76	85	
> 18 to 22 GHz	99	108	74	83	
> 22 to 35 GHz	95	105	70	80	
> 35 to 40 GHz	88	100	63	75	
> 40 to 46 GHz	81	93	56	63	
> 46 to 50 GHz	77	88	52	63	

¹ Dynamic range is decreased from 3 to 9 dB at 2 MHz.

Absolute power and gain measurement uncertainties

Verified with input level of -10 dBm, peak detector, 10 dB attenuation, preamplifier off, all settings auto-coupled, no warm-up required. Includes frequency response uncertainties. Assumes an ERTA system using a Keysight 11667A, 11667B, or 11667C power splitter.

N991xA and N993xA				
Input power (R) measurements uncertainty, 30 kHz RBW (dB)				
	Spec (23 ± 5 °C)	Spec (-10 to 55 °C)	Typical (23 ± 5 °C)	Typical (-10 to 55 °C)
100 kHz to 18 GHz	± 1.10	± 1.30	± 0.40	± 0.50
> 18 to 26.5 GHz	± 1.40	± 1.50	± 0.50	± 0.60
Output power (B) measurement uncertainty, frequency references locked to GPS, RBW ≥ 3 kHz (dB)				
	Spec (23 ± 5 °C)	Spec (-10 to 55 °C)	Typical (23 ± 5 °C)	Typical (-10 to 55 °C)
100 kHz to 18 GHz	± 1.00	± 1.20	± 0.40	± 0.50
> 18 to 26.5 GHz	± 1.20	± 1.40	± 0.50	± 0.60
Output power (B) measurement uncertainty, frequency references unlocked, RBW ≥ 300 kHz (dB)				
	Spec (23 ± 5 °C)	Spec (-10 to 55 °C)	Typical (23 ± 5 °C)	Typical (-10 to 55 °C)
100 kHz to 18 GHz	± 1.00	± 1.30	± 0.40	± 0.50
> 18 to 26.5 GHz	± 1.40	± 1.60	± 0.50	± 0.60
Gain/Loss (B/R) measurement uncertainty, frequency references locked to GPS, RBW ≥ 3 kHz (dB)				
	Spec (23 ± 5 °C)	Spec (-10 to 55 °C)	Typical (23 ± 5 °C)	Typical (-10 to 55 °C)
100 kHz to 18 GHz	± 1.30	± 1.70	± 0.60	± 0.70
> 18 to 26.5 GHz	± 1.70	± 2.10	± 0.70	± 0.90
Gain/Loss (B/R) measurement uncertainty, frequency references unlocked, RBW ≥ 300 kHz (dB)				
	Spec (23 ± 5 °C)	Spec (-10 to 55 °C)	Typical (23 ± 5 °C)	Typical (-10 to 55 °C)
100 kHz to 18 GHz	± 1.40	± 1.70	± 0.70	± 0.70
> 18 to 26.5 GHz	± 2.00	± 2.10	± 0.90	± 1.00
N995xA and N996xA				
Input power (R) measurements uncertainty, 30 kHz RBW (dB)				
	Spec (23 ± 5 °C)	Spec (-10 to 55 °C)	Typical (23 ± 5 °C)	Typical (-10 to 55 °C)
2 MHz to 18 GHz	± 1.10	± 1.30	± 0.50	± 0.60
> 18 to 32 GHz	± 1.20	± 1.50	± 0.50	± 0.70
> 32 to 40 GHz	± 1.30	± 1.80	± 0.60	± 0.80
> 40 to 43 GHz	± 1.60	± 2.30	± 0.70	± 1.10
> 43 to 50 GHz	± 1.70	± 3.20	± 0.80	± 1.40

Absolute power and gain measurement uncertainties (continued)

Output power (B) measurement uncertainty, frequency references locked to GPS, RBW ≥ 3 kHz (dB)				
	Spec (23 ± 5 °C)	Spec (-10 to 55 °C)	Typical (23 ± 5 °C)	Typical (-10 to 55 °C)
2 MHz to 18 GHz	± 0.40	± 1.00	± 0.40	± 0.50
> 18 to 32 GHz	± 0.45	± 1.30	± 0.40	± 0.60
> 32 to 40 GHz	± 0.50	± 1.50	± 0.50	± 0.70
> 40 to 43 GHz	± 0.80	± 2.30	± 0.70	± 1.00
> 43 to 50 GHz	± 0.90	± 3.00	± 0.80	± 1.40
Output power (B) measurement uncertainty, frequency references unlocked, RBW ≥ 300 kHz (dB)				
	Spec (23 ± 5 °C)	Spec (-10 to 55 °C)	Typical (23 ± 5 °C)	Typical (-10 to 55 °C)
2 MHz to 18 GHz	± 1.00	± 1.10	± 0.40	± 0.50
> 18 to 32 GHz	± 1.20	± 1.50	± 0.50	± 0.60
> 32 to 40 GHz	± 1.60	± 1.90	± 0.60	± 0.80
> 40 to 43 GHz	± 2.10	± 2.50	± 0.70	± 1.30
> 43 to 50 GHz	± 2.60	± 3.60	± 1.00	± 1.60
Gain/Loss (B/R) measurement uncertainty, frequency references locked to GPS, RBW ≥ 3 (dB)				
	Spec (23 ± 5 °C)	Spec (-10 to 55 °C)	Typical (23 ± 5 °C)	Typical (-10 to 55 °C)
2 MHz to 18 GHz	± 1.40	± 1.70	± 0.60	± 0.70
> 18 to 32 GHz	± 1.50	± 2.00	± 0.70	± 0.90
> 32 to 40 GHz	± 1.60	± 2.30	± 0.80	± 1.00
> 40 to 43 GHz	± 2.20	± 3.10	± 1.00	± 1.40
> 43 to 50 GHz	± 2.40	± 4.00	± 1.20	± 1.90
Gain/Loss (B/R) measurement uncertainty, frequency references unlocked, RBW ≥ 300 kHz (dB)				
	Spec (23 ± 5 °C)	Spec (-10 to 55 °C)	Typical (23 ± 5 °C)	Typical (-10 to 55 °C)
2 MHz to 18 GHz	± 1.40	± 1.70	± 0.70	± 0.70
> 18 to 32 GHz	± 1.80	± 2.10	± 0.80	± 1.00
> 32 to 40 GHz	± 2.10	± 2.80	± 1.00	± 1.30
> 40 to 43 GHz	± 2.70	± 3.50	± 1.40	± 1.70
> 43 to 50 GHz	± 3.00	± 4.80	± 1.60	± 2.40

Cable correction

Input and output jumper cable losses can be accounted for using ERTA's cable correction wizard.

The performance listed in built-in power meter, external USB power sensor support, pulse measurements, USB power sensor measurements versus frequency, built-in GPS receiver, DC bias variable voltage source and remote control capability sections applies to the capabilities available in the following models:

FieldFox RF & microwave (combination) analyzers:	N9913A, N9914A, N9915A, N9916A, N9917A, N9918A N9950A, N9951A, N9952A
FieldFox microwave spectrum analyzers:	N9935A, N9936A, N9937A, N9938A N9960A, N9961A, N9962A

See [FieldFox Configuration Guide](#) for option information. Many capabilities listed in this Data Sheet require options.

Built-in Power Meter (Option 310)

Using the built-in power meter, FieldFox is able to make very accurate channel power measurements. The channel bandwidth can be set wide to simulate average power meter measurements. This measurement function provides the flexibility to make user definable channel power measurements.

Description			
Setup parameters	Center frequency, including selection of radio standards and channel selection, span or channel width		
Functions	Relative/absolute measurements, offsets, units of dBm or Watts, or dB or %, minimum and maximum limits		
Models	Frequency range		
N991xA, N992xA, N993xA	N9913A	100 kHz to 4 GHz	Usable to 5 kHz
	N9914A	100 kHz to 6.5 GHz	Usable to 5 kHz
	N9915A, N9925A, N9935A	100 kHz to 9 GHz	Usable to 5 kHz
	N9916A, N9926A, N9936A	100 kHz to 14 GHz	Usable to 5 kHz
	N9917A, N9927A, N9937A	100 kHz to 18 GHz	Usable to 5 kHz
	N9918A, N9928A, N9938A	100 kHz to 26.5 GHz	Usable to 5 kHz
N995xA, N996xA	N9950A, N9960A	9 kHz to 32 GHz	Usable to 5 kHz
	N9951A, N9961A	9 kHz to 44 GHz	Usable to 5 kHz
	N9952A, N9962A	9 kHz to 50 GHz	Usable to 5 kHz

Amplitude accuracy (dB)				
N991xA, N992xA, N993xA	Spec (23 ± 5 °C)	Spec (-10 to 55 °C)	Typical (23 ± 5 °C)	Typical (-10 to 55 °C)
10 dB attenuation, input signal -15 to -5 dBm, peak detector, preamplifier off, 300 Hz RBW, all settings auto-coupled, includes frequency response uncertainties. No warm-up required.				
100 kHz to 18 GHz	± 0.80	± 1.00	± 0.35	± 0.50
> 18 to 26.5 GHz	± 1.00	± 1.20	± 0.50	± 0.60
N995xA, N996xA	Spec (23 ± 5 °C)	Spec (-10 to 55 °C)	Typical (23 ± 5 °C)	Typical (-10 to 55 °C)
9 to 100 kHz	± 1.60	± 2.50	± 0.60	± 1.30
> 100 kHz to 2 MHz	± 1.30	± 1.90	± 0.60	± 0.80
> 2 to 15 MHz	± 1.00	± 1.20	± 0.30	± 0.50
> 15 MHz to 32 GHz	± 0.80	± 1.00 ¹	± 0.30	± 0.50
> 32 to 40 GHz	± 0.90	± 1.40	± 0.50	± 0.70
> 40 to 43 GHz	± 1.30	± 2.00	± 0.50	± 0.70
> 43 to 50 GHz	± 1.40	± 2.70	± 0.50	± 0.90

¹ Increase by 0.2 dB between 18 and 32 GHz.

External USB Power Sensor Support (Option 302)

The external USB power sensor option supports various Keysight USB power sensors. For an up-to-date listing of the supported power sensors, visit <http://www.keysight.com/find/fieldfoxsupport>.

	Description
Setup parameters	Frequency
Functions	Relative/absolute measurements, offsets, units of dBm or Watts, or dB or %, minimum and maximum limits.
Internal source	FieldFox's internal source can be turned on in the USB power sensor mode. CW frequency and nominal power level control are available.

Pulse Measurements (Option 330)

FieldFox's pulse measurement option can be used to characterize RF pulses such as those used in radar and electronic warfare systems. Measurements are made using FieldFox and Keysight's USB peak power sensors.

Performance specifications such as frequency, dynamic range and minimum pulse width depend on the peak power sensor. Supported peak power sensors: <http://www.keysight.com/find/fieldfoxsupport>

	Description
Setup parameters	Frequency, time (center), time/division, gating, triggering, video bandwidth, averaging
Functions	Average power, peak power, and peak to average ratio
	Analog gauge display and digital display, dBm and Watts
	Relative/absolute measurements, offset, dB or %, minimum and maximum limits
	Trace graph for pulse profiling with gating
	Rise time, fall time, pulse width, pulse period, pulse repetition frequency

USB Power Sensor Measurements versus Frequency (Option 208)

This feature allows FieldFox's source frequency to be set independently from the power sensor (receiver) frequency. With frequency-offset using power sensor (FOPS), the frequency of both the source and receiver are swept, and the two track each other. The offset frequency can be negative, zero, or positive.

FOPS can be used to characterize the scalar transmission response of devices such as mixers and converters. This frequency-offset capability is necessary for conversion loss/gain measurements on frequency-translating devices, since by definition, the input and output frequencies of the DUT are different. The FieldFox source stimulates the DUT and the power sensor is used as the measurement receiver.

Since power sensors are inherently broadband devices (not frequency-selective), the user should ensure that only the signal of interest is present at the power sensor input and that all other signals are filtered appropriately.

USB Power Sensor Measurements versus Frequency (continued)

Setup parameters	
Source frequency	Center/span or start/stop
Receiver frequency	Range determined by power sensor range
Frequency offset	Positive offset or negative offset
Frequency step size	30 kHz minimum
Number of points	2 to 1601
Combination of number of points and frequency step size limited by span.	
Dwell time/point	0 to 1.0 sec

Source frequency span must be equal to receiver frequency span.

Receiver sweep direction: forward (default setting) or reverse.

For some DUTs, the output frequency may sweep in a reverse direction, as compared to the source frequency. The basic relationships between the source, receiver and offset frequencies are shown in the table below. The FieldFox analyzer includes an offset calculator that ensures a fast measurement setup.

Src sweep direction	Rx sweep direction	Frequency calculations
Forward $f_{2src} > f_{1src}$	Forward $f_{2rx} > f_{1rx}$	Receiver frequency = Source frequency \pm Offset
Forward $f_{2src} > f_{1src}$	Reverse $f_{2rx} > f_{1rx}$	Receiver frequency = Offset - Source Frequency Offset > Source frequency

	Description
Measurements	Source power, gain/loss and receiver (Rx) power Gain = Rx power / source power (memory). Source power (memory) is measured during setup.
Output power	Refer to the test port output power typical data on page 5.
Dynamic range	The dynamic range with FOPS is dependent on FieldFox's output power and the power sensor's dynamic range. Supported USB power sensors: www.keysight.com/find/fieldfoxsupport

The graph below shows a filter measurement using two different power sensors, the U2002A (- 60 to +20 dBm) and the U2021XA (- 45 to +20 dBm). While a filter is not commonly measured using FOPS, it is a useful device for demonstrating dynamic range.

For both measurements, the FieldFox source power was set to - 1 dBm, the maximum available in the selected frequency range of 7.25 to 13.25 GHz. An external amplifier was not used in this case, but one can be added to increase the source power and hence dynamic range.

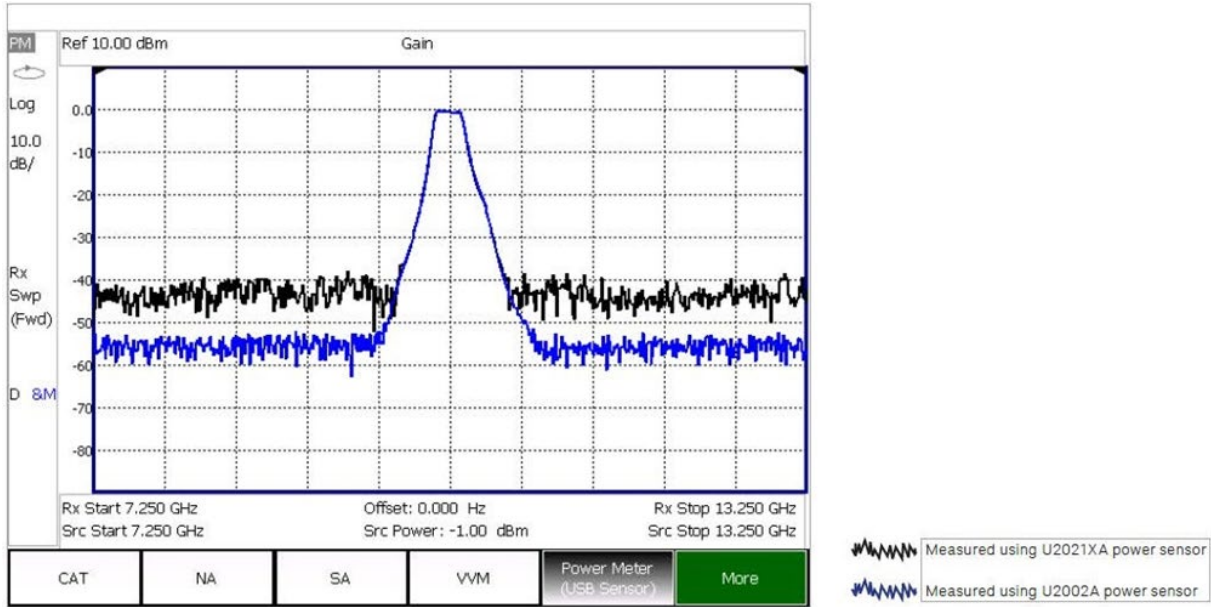

Example showing typical dynamic range of FOPS

Built-In GPS Receiver (Option 307)

	Description
GPS receiver	The internal GPS receiver can be used as a frequency reference. ¹
Modes	Off, internal, external
Sync clock	On, off
Functionality	Geo-location: latitude, longitude, altitude (elevation), time, sync time/date Requires external GPS antenna (can use N9910X-825, GPS active antenna)
Connector for antenna	SMA (f), 3.3 V
Maximum DC current	13 mA

DC Bias Variable-Voltage Source (Option 309)

	Description
	Nominal
Connector	SMB (m)
Voltage	+1 to +32 V
Resolution	0.1 V
Maximum current ²	0.65 A
DC current readout resolution	0.01 A
Maximum power ²	7 watts
Display read out	Voltage, current
Overload trip protection	Automatically engages when voltage source is on. The trip circuit can be reset from front panel without presetting or power cycling the analyzer.

¹ External GPS USB receivers can be used to provide geo-location data. However, they cannot be used for frequency reference locking.

² Battery life will be reduced when DC source is used. A trip function turns off the power supply when the rated current or power is exceeded.

Remote Control Capability (Option 030)

Option 030 adds remote control capability to FieldFox analyzers, so that FieldFox can be controlled via an iOS device, or an Android device. The FieldFox app, running on the iOS/Android device, combined with Option 030 on the FieldFox analyzer provides full control of the instrument from a remote location. The app emulates the front panel of FieldFox, so users can press the FieldFox hard keys or softkeys using their iPhone/iPad, or Android mobile device and make measurements remotely. For example, a tower climber can be on the tower with a FieldFox analyzer, while the technician controls and makes the measurements down below, using an iPad. The iPad and FieldFox communicate via a network connection.

iOS device requirements	Android device requirements
iPad, iPhone, or iPod Touch	Android phone, tablet PC
iOs of 6.1 or higher	Android OS of 9.0 or higher
A WiFi or cellular network connection	A WiFi or cellular network connection

The FieldFox app communicates with FieldFox via a network connection, so both the iOS/Android device and FieldFox need to be on a network where both devices can reach the other. For example, a company intranet or a site installation using a wireless router. FieldFox can directly be connected to a LAN cable, or if wired LAN is not available, a user supplied wireless router can be configured to work with FieldFox. FieldFox does not include a wireless router.

FieldFox app without Option 030

The FieldFox app can be installed on an iOS or an Android device independent of the presence of Option 030 on the analyzer. Without Option 030, users can view the live display screen of their FieldFox remotely but cannot control the instrument. With 030 purchased and installed on their FieldFox, users can both view and control their FieldFox. Control refers to the ability to press hard keys, softkeys, make or change measurements, etc. Option 030 does not include the iOS or the Android device itself. Users must supply their own iOS or Android device. Option 030 is a license on the FieldFox analyzer. Option 030 and the FieldFox app are not applicable to BlackBerry, or Windows phone/tablet devices. FieldFox can be remotely controlled via PC software using a wireless or wired LAN connection. FieldFox Data Link software provides a remote display tool with a virtual keypad that allows remote access to the FieldFox display (Option 030 not required).

EMI measurements (Option 361)

	Description
Frequency Range	Same as spectrum analyzer frequency range
Number of traces	4, each trace can be configured with individual trace mode and detector type
Trace mode	Max hold, Min, Clear/Write, View and blank. (Average is implemented as EMI average detector)
Detector	Positive Peak, Quasi-Peak, EMI average
CISPR bandwidth	200 Hz, 9 kHz, 120 kHz, 1MHz
Measurements	Frequency scan, CISPR 16-1-1 Amplitude probability distribution (APD)

General Information

Calibration cycle	
	1 year
Weight	
N991xA, N992xA, N993xA	3.0 kg or 6.6 lb. including battery
N995xA, N996xA	3.2 kg or 7.1 lb. including battery
Dimensions: H x W x D	
	292 x 188 x 72 mm (11.5 in x 7.4 in x 2.8 in)

Environmental	
MIL-PRF-28800F Class 2	Operating temperature Storage temperature Operating humidity Random vibration Functional shock Bench drop
Maximum humidity	Maximum relative humidity (non-condensing): 95% relative humidity up to 40°C, decreases linearly to 45% relative humidity at 55°C ¹
Altitude – operating	9,144 m or 30,000 ft (using battery)
Altitude – Non-operating	15,240 m or 50,000 ft
Altitude – AC to DC adapter	3,000 m or 9,840 ft

Ingress protection	This product has been type tested to meet the requirements for ingress protection IP53 in accordance with IEC/EN 60529 (IP rating for instrument by itself, with no cover).
---------------------------	---

Temperature range	
Operating, AC power, spec	-10 to 55°C (14 to 131°F) (-10 to 45°C/14 to 113°F in RTSA mode)
Operating, battery, spec	-10 to 50°C (14 to 122°F)
Operating, battery, typical	-10 to 55°C (14 to 131°F)
Storage, spec ²	-51 to 71°C (-60 to 160°F)

EMC: Complies with the essential requirements of the European Radio Equipment Directive as well as current editions of the following standards (dates and editions are cited in the Declaration of Conformity):

IEC/EN 61326-1
EN 301 489-1, EN 301 489-19
CISPR Pub 11 Group 1, Class B
AS/NZS CISPR 11
ICES/NMB-001

This ISM device complies with Canadian ICES-001.
Cet appareil ISM est conforme a la norme NMB-001 du Canada.

Radio Equipment (GNSS):	Complies with the essential requirements of the European Radio Equipment Directive: EN 303413
--------------------------------	--

¹ From 40 °C to 55 °C, the maximum % relative humidity follows the line of constant dew point.

² The battery packs should be stored in an environment with low humidity. Extended exposure to temperature above 45°C could degrade battery performance and life.

SAFETY: Complies with the essential requirements of the European Low Voltage Directive as well as current editions of the following standards (dates and editions are cited in the Declaration of Conformity):

IEC/EN 61010-1

Canada: CSA C22.2 No. 61010-1

USA: UL std no. 61010-1

To find a current Declaration of Conformity for a specific Keysight product, go to: <http://www.keysight.com/go/conformity>

Explosive environment

This product has been type tested to meet the requirements for operation in explosive environments in accordance with MIL-STD-810G, Method 511.5, Procedure I.

General Information (continued)

Power supply	
External DC input	15 to 19 VDC, 40 watts maximum when battery charging
External AC power adapter	Efficiency level IV
Input	100 to 250 VAC, 50 to 60 Hz, 1.25 to 0.56 A
Output	15 VDC, 4 A
Power consumption	14 watts typical, mode dependent
Battery	
Lithium ion	10.8 V, 4.6 A-h
Operating time	3.5 hours (typical), mode dependent
Charge time	A fully discharged battery takes about 1.5 hours to recharge to 80%. Four hours to 100%.
Discharge temperature limits	-10 to 60°C, ≤ 85% RH
Charge temperature limits	0 to 45°C, ≤ 85% RH
Storage temperature limits	-20 to 50°C, ≤ 85 % RH
	The battery packs should be stored in an environment with low humidity. Extended exposure to temperatures above 45°C could degrade battery performance and life.
Test port connectors	
≤ 18 GHz models	Type-N (f)
26.5 GHz models	3.5 mm (m) for FieldFox microwave analyzer, N9918A and FieldFox microwave VNA analyzer, N9928A. On FieldFox SA N9938A, you may choose 3.5 mm (m) or Type-N (f). Type-N (f) port connector is not available for the 26.5 GHz microwave analyzer, N9918A or 26.5 GHz microwave VNA analyzer, N9928A
≥ 32 GHz models	NMD 2.4mm (m), torque .9 Nm or 8 in-lb, use torque wrench N9910X-886
Display	
	6.5" transfective color LCD-LED backlit
Headphone jack connector	
	3.5 mm (1/8 inch) miniature audio jack
USB-A, 2-ports	
	Hi-speed USB 2.0
Mini USB, 1 port¹	
	Hi-speed USB 2.0; used for SCPI programming; USBTMC (USB IEEE488)
Keyboard	
	USB keyboards are supported (user must supply their own keyboard)
LAN	
Connector	RJ-45
	Used for programming, data saving, remote control, and connection to DataLink software
N991xA, N992xA, N993xA	100/10 base-T (auto switching)
N995xA, N996xA	1000/100/10 base-T (auto switching)
	SCPI over LAN using sockets and VX11 (LAN IEEE488); HTTP

¹ SCPI over USB for the N991x/2x/3x models is only available for serial number prefix starting with MY5607/SG5607/US5607 or upgraded with Option N9910HU-100/200/300/400.

General Information (continued)

Programming	SCPI, using the built-in LAN interface, BenchVue
Languages	English, Spanish, German, Italian, French, Russian, Japanese, Chinese, Turkish, Korean, and Portuguese
Preset	User preset for both mode preset and complete system preset
Limit lines	<p>The limit line capabilities listed in this section apply to the cable and antenna analyzer, network analyzer and spectrum analyzer modes in all FieldFox analyzers.</p> <ul style="list-style-type: none">• Limit lines can be a combination of horizontal lines, sloping lines, or discrete data points• Limit types: Fixed or relative• Each trace can have its own limit line• Limit lines can be built from a current trace• Limit segments > 100, limited by memory size• Max limit line number of points: 10,001• Beep: Beep off, Beep on fail, Beep on pass• Pass/fail warning: on/off• Offset and margin: An increase or decrease in the limit line• Save/recall limit lines
Data storage	
Internal	Internal Minimum: 4 GB Minimum states and traces: 1000
External	Supports USB 2.0 compatible memory devices and SD/SDHC memory cards
Data types	Trace, trace+state, picture (png), data (csv), S1P, S2P
Secure operation	
Frequency blanking	For protection of sensitive data all frequency information can be turned off.
Erase user data	All user data can be erased on a FieldFox analyzer. For more information visit: http://www.keysight.com/find/securefieldfox
Reference out/trigger out	
Connector	SMB (m), 50 Ω
Output amplitude	≥ 0 dBm
Frequency	10 MHz (1 + frequency reference accuracy)
Trigger out	Reserved for future use; currently only used for ERTA 2-box handshaking
Reference in/trigger in	
Connector	SMA (f), 50 Ω
Reference input	10 MHz, - 5 to +10 dBm
Trigger input	3.3 or 5 V TTL logic levels

FieldFox Physical Dimensions

FieldFox models with Type-N test port connectors

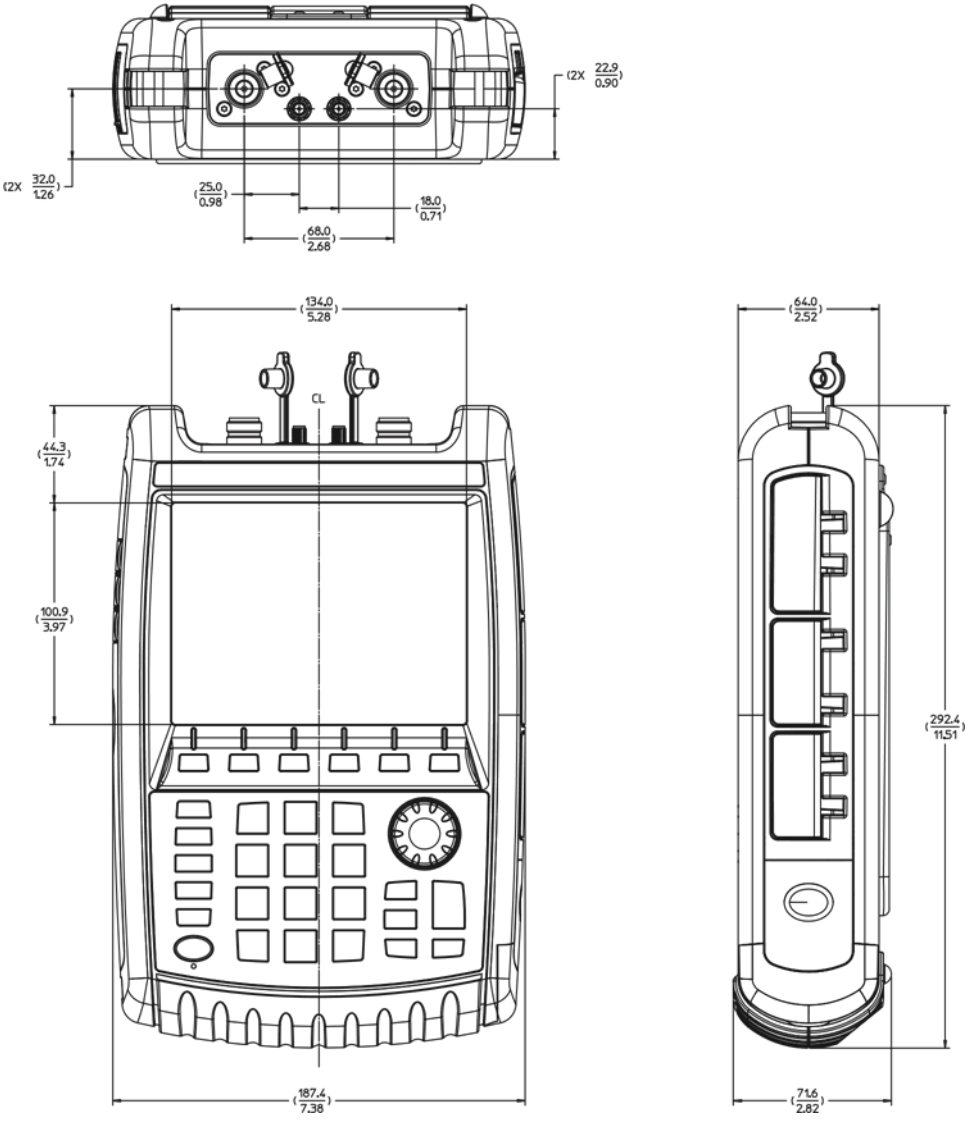

FieldFox Physical Dimensions (continued)

FieldFox models with 3.5 mm test port connectors

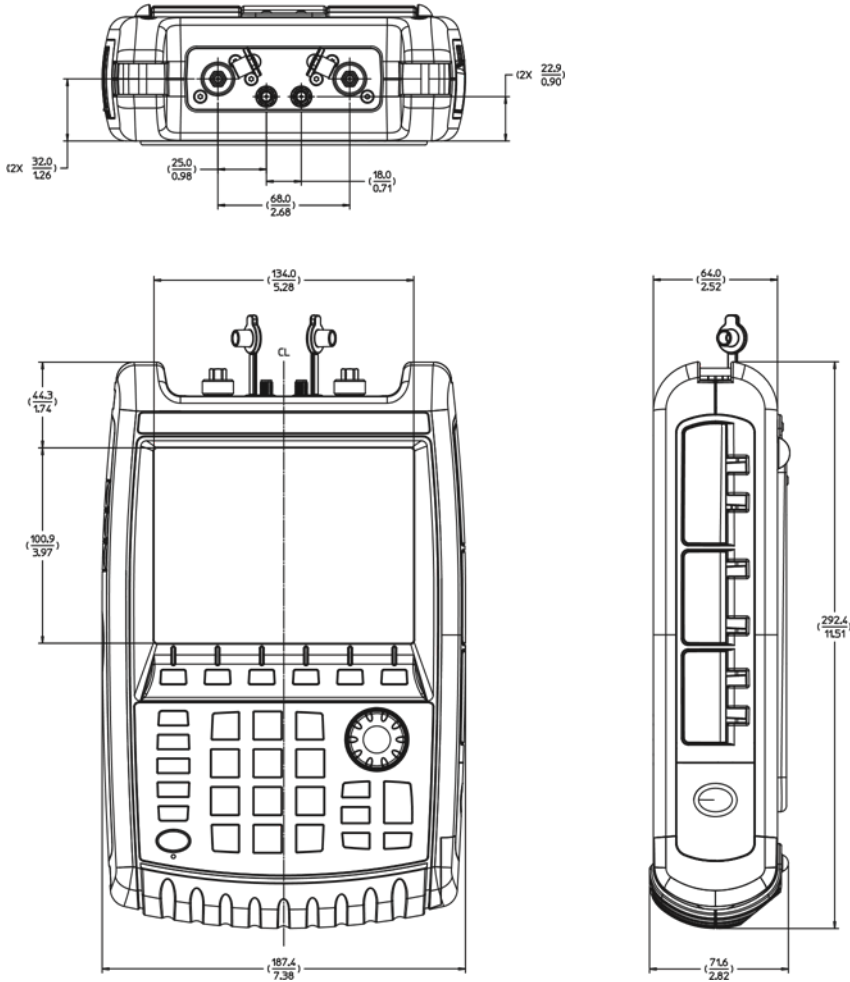

FieldFox Physical Dimensions (continued)

FieldFox models with 2.4 mm test port connectors

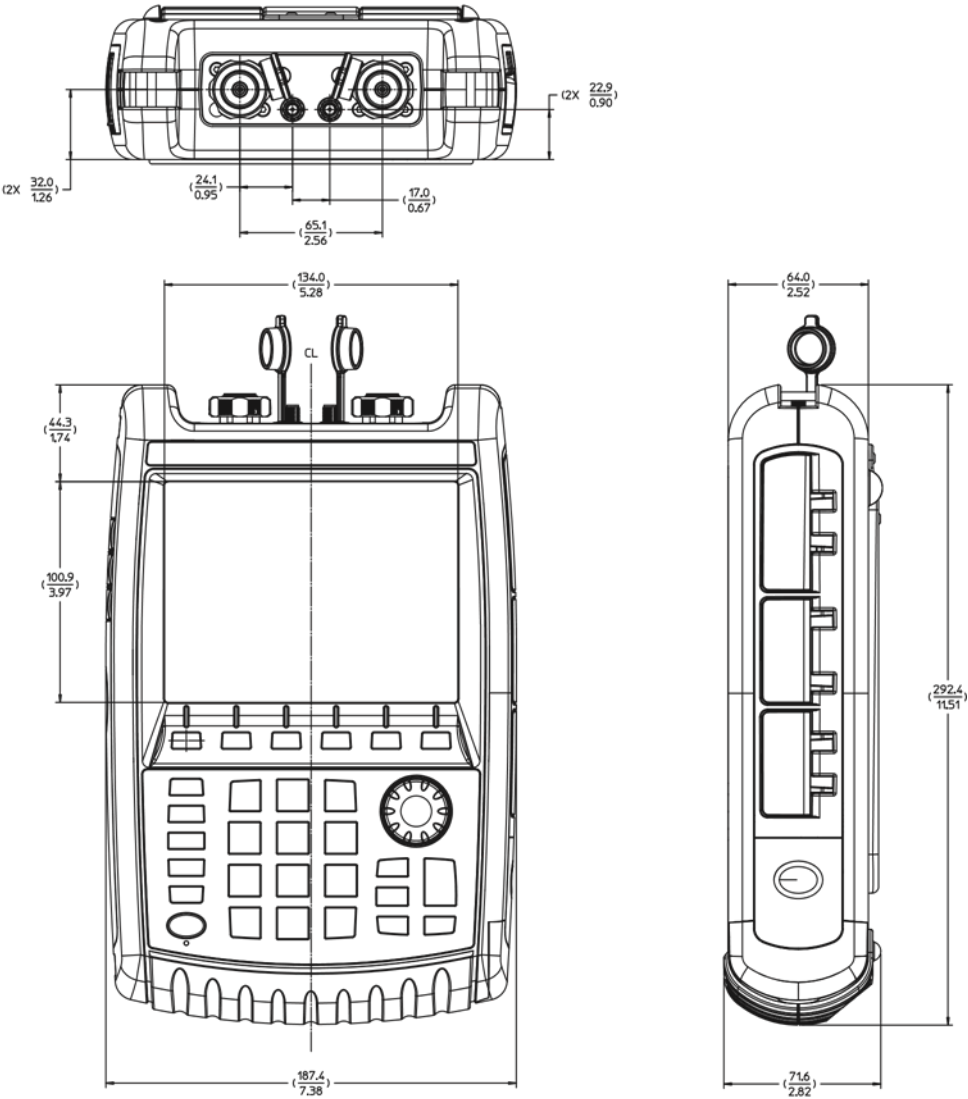

Carry Precision with You

Every piece of gear in your field kit had to prove its worth. Measuring up and earning a spot is the driving idea behind Keysight's FieldFox analyzers. They're equipped to handle routine maintenance, in-depth troubleshooting and anything in between. Better yet, FieldFox delivers precise microwave measurements—wherever you need to go. Add FieldFox to your kit and carry precision with you.

Related literature	Publication number
FieldFox Handheld Analyzers, Configuration Guide	5990-9836EN
FieldFox Handheld Analyzers, Technical Overview	5992-0772EN
FieldFox N9923A RF Vector Network Analyzer, Technical Overview	5990-5087EN
FieldFox N9923A RF Vector Network Analyzer, Data Sheet	5990-5363EN
FieldFox N9912A RF Analyzer, Technical Overview	5989-8618EN
FieldFox N9912A RF Analyzer, Data Sheet	N9912-90006

Download application notes, watch videos, and learn more: www.keysight.com/find/fieldfox

Learn more at: www.keysight.com

For more information on Keysight Technologies' products, applications or services, please contact your local Keysight office. The complete list is available at: www.keysight.com/find/contactus



B1.2 Anritsu N6850A Broadband Omni-directional Antenna Datasheet

Keysight Technologies

N6850A Broadband Omnidirectional Antenna

Data Sheet



Industries and Applications

- Spectrum monitoring and signal location, outdoor and indoor
- Interference Detection and location
- Fixed-site, vehicle-mounted, or handheld operation
- For use with N6841A RF Sensor, N99XX handheld spectrum analyzers, spectrum analyzers, or any receiver

Product Description

For your spectrum monitoring or interference detection applications, having an antenna that covers the entire frequency range of interest would be most convenient. Assembling discrete antennas is time-consuming and usually has to be done on-site as they are hard to transport without damaging the elements and may require multiple antennas to cover the full frequency range of the receiver. Other antennas may not have uniform gain patterns that are required by received signal strength geolocation algorithms.

The Keysight Technologies, Inc. N6850A Broadband Omni Antenna is a passive, omnidirectional antenna designed for receivers that operate up to 6 GHz. With this antenna, you can minimize mounting complexity by mounting only one very compact antenna. Its low profile design makes it ideal for inconspicuous spectrum monitoring applications. Its uniform gain pattern makes it ideal for time difference of arrival or for received signal strength geolocation techniques.



Figure 1. The antenna and the bracket

Main Features and Benefits

Product Features	Your Benefits
Wide frequency range	Covers 20 MHz to 6 GHz, meaning you only need only 1 antenna with your RF sensor or other receiver
Uniform gain pattern	Suitable for indoor or outdoor geolocation
Mounting adapter	Suitable for post or rail mounting, or handheld use. Easily adapted for vehicle mounting.
Compact design, low wind loading	Suitable for signal monitoring from tower or vehicle. Easy to transport, easy to mount.

Specifications and Characteristics

All specs and plots are Typical unless otherwise stated.

Product Features	Your Benefits
Frequency range	20 MHz to 6 GHz
Type	Omnidirectional, Passive
Size	16.5 inch high x 6.14 inch wide
Connector	Type N
Polarization	Vertical
Impedance	50 ohms
VSWR	< 2.5 for 450 MHz to 6 GHz
Operating Temperature	-50 to +70°C
Ingress	IP67
Wind Survivability	100 miles/hr (160 km/hr)
ROHS	Compliant
Antenna weight	Approx. 1.15 kg
Mounting bracket weight	Approx 1.54 kg
Shipping weight	Approx 6.1 kg

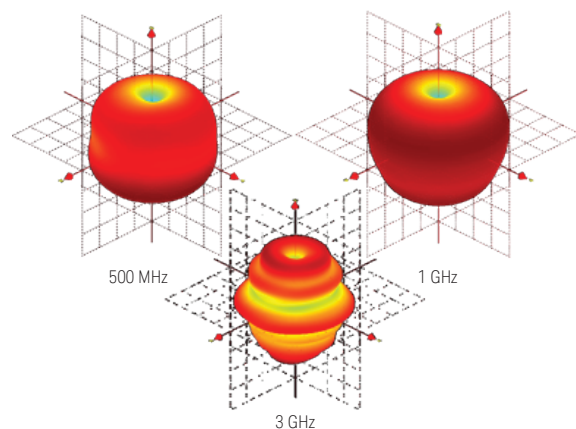

Figure 2. 3D gain plot of a representative unit at ambient temp

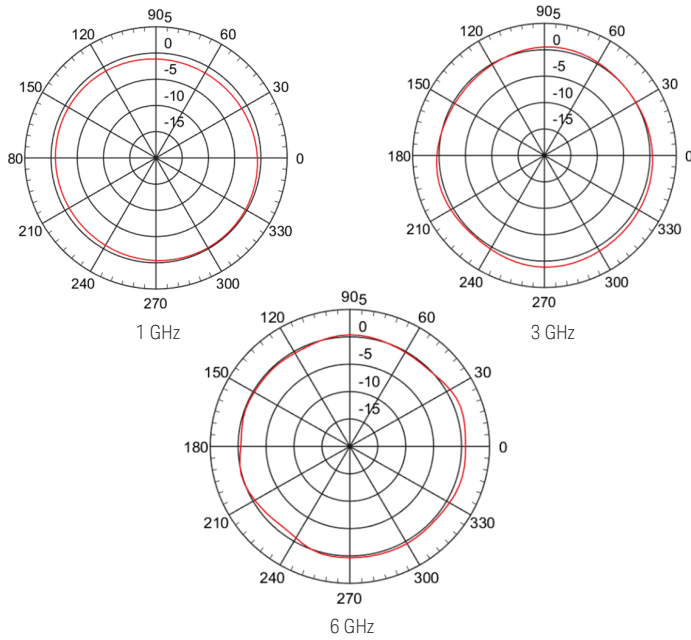

Figure 3. Radial gain pattern at the horizon of a representative unit at ambient temperature

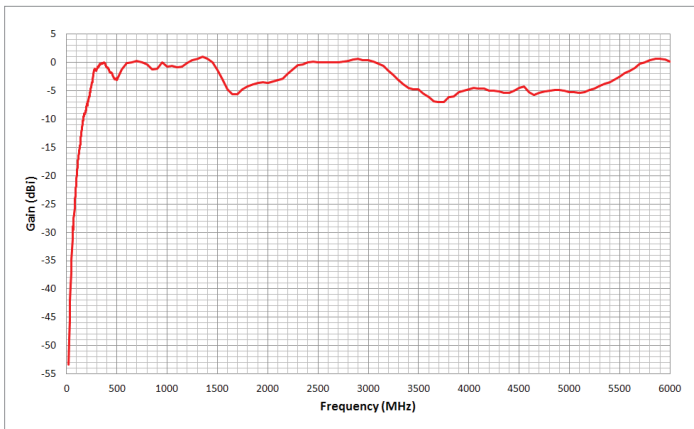

Figure 4. Average gain at the horizon at ambient temperature

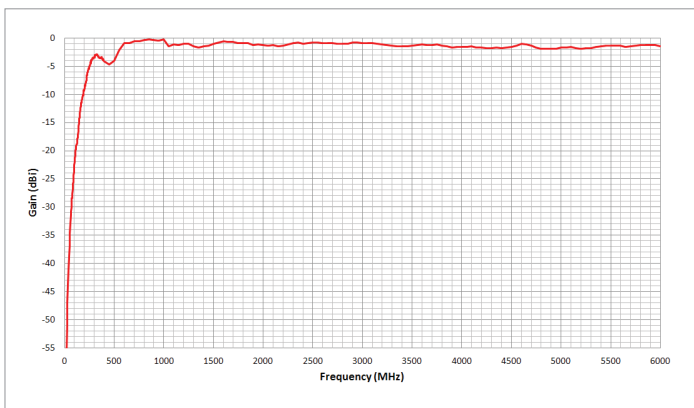

Figure 5. Average gain over all space at ambient temperature

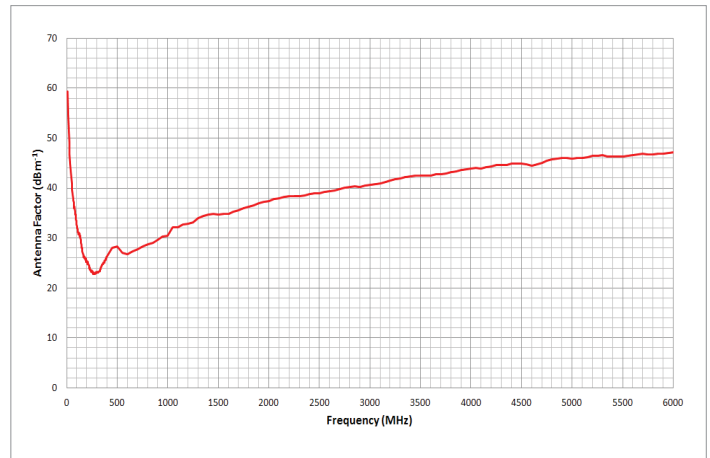
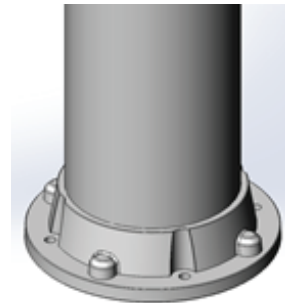

Figure 6. Average antenna factor over all space at ambient temperature

Mounting

There are 4 threaded inserts and 4 through-holes for mounting the antenna. You may use the enclosed mounting bracket or devise your own mount.



The 4 threaded inserts will accept 1/4"-20 x 0.5" (inch) length machine screws with 1/4" washer. The through-holes will accept 1/4"-20 x 1" (inch) bolt and nut. When used with our mounting bracket, you may mount with either the 4 through-holes or the 4 threaded inserts.

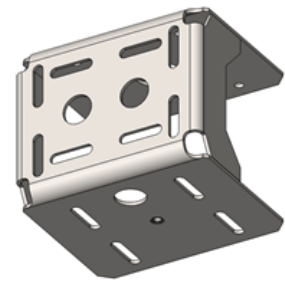

The mounting bracket can be vertical pole or horizontal rail mounted with 2 U-bolts (not included). All slots accommodate U-bolts for 1" to 3" diameter pipe.

Mount designed for 5/16" diameter U-bolts.

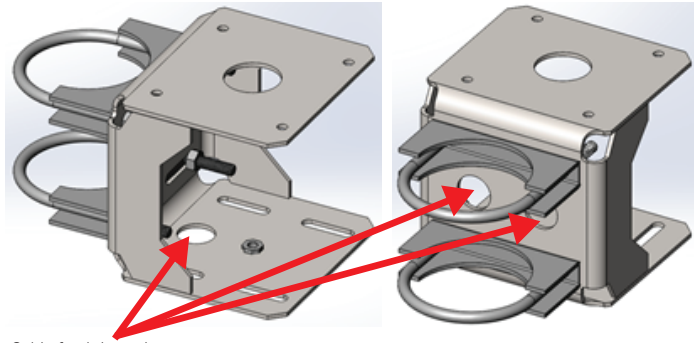

Cable feed through

U-bolts for vertical pole mounting (U-bolts not included)

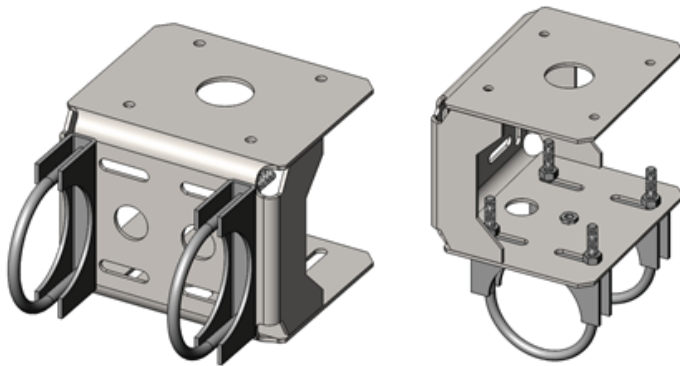

U-bolts for horizontal rail mounting (U-bolts not included)

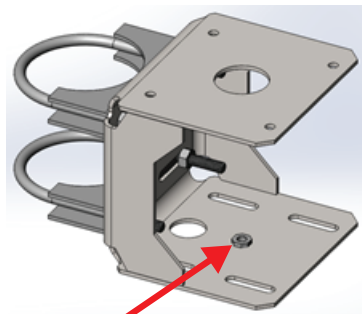

1/4-20 Tripod mount

Vehicle mounting can be done by purchasing a magnetic mount with a 1/4-20 tripod screw.

Dimensions

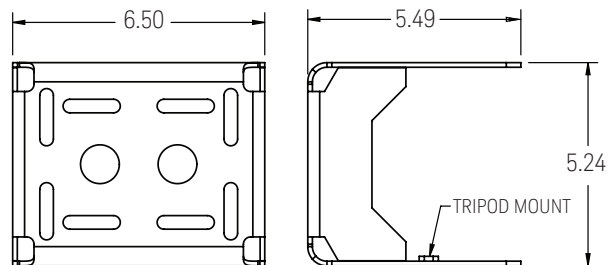
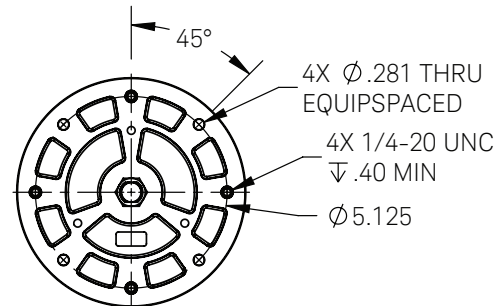
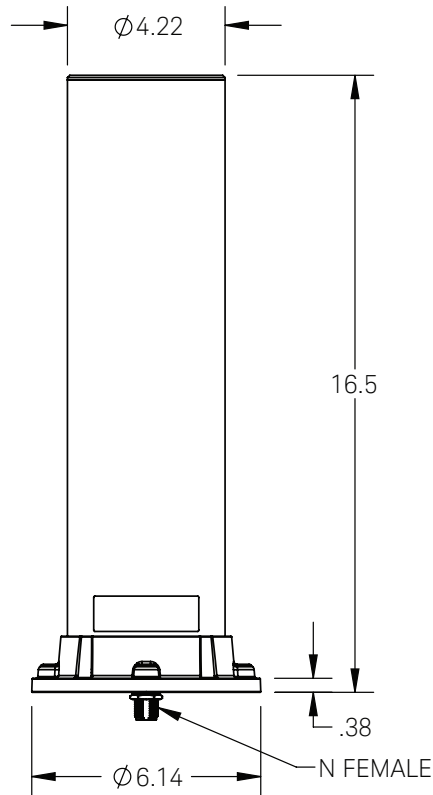

Ordering Information

Model	Description
N6850A	Broadband omni antenna (6 GHz) Includes post/rail mounting adapter N-type antenna cable (5 ft) Mounting instructions

(Note: vehicle mount not included)

Evolving Since 1939

Our unique combination of hardware, software, services, and people can help you reach your next breakthrough. We are unlocking the future of technology.

From Hewlett-Packard to Agilent to Keysight.

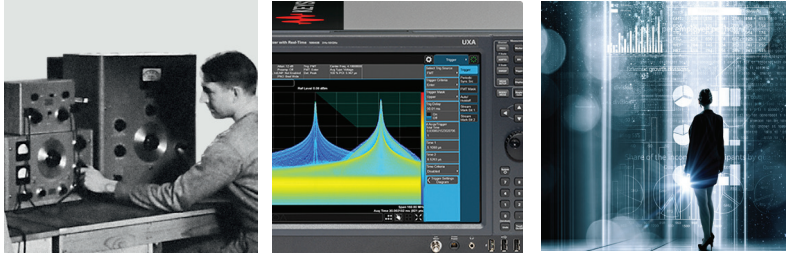

For more information on Keysight Technologies' products, applications or services, please contact your local Keysight office. The complete list is available at:

www.keysight.com/find/contactus

Americas

Canada	(877) 894 4414
Brazil	55 11 3351 7010
Mexico	001 800 254 2440
United States	(800) 829 4444

Asia Pacific

Australia	1 800 629 485
China	800 810 0189
Hong Kong	800 938 693
India	1 800 11 2626
Japan	0120 (421) 345
Korea	080 769 0800
Malaysia	1 800 888 848
Singapore	1 800 375 8100
Taiwan	0800 047 866
Other AP Countries	(65) 6375 8100

Europe & Middle East

Austria	0800 001122
Belgium	0800 58580
Finland	0800 523252
France	0805 980333
Germany	0800 6270999
Ireland	1800 832700
Israel	1 809 343051
Italy	800 599100
Luxembourg	+32 800 58580
Netherlands	0800 0233200
Russia	8800 5009286
Spain	800 000154
Sweden	0200 882255
Switzerland	0800 805353
	Opt. 1 (DE)
	Opt. 2 (FR)
	Opt. 3 (IT)
United Kingdom	0800 0260637

For other unlisted countries:

www.keysight.com/find/contactus
(BP-9-7-17)

DEKRA Certified
ISO 9001 Quality Management System

www.keysight.com/go/quality
Keysight Technologies, Inc.
DEKRA Certified ISO 9001:2015
Quality Management System

myKeysight

myKeysight

www.keysight.com/find/mykeysight

A personalized view into the information most relevant to you.

http://www.keysight.com/find/emt_product_registration

Register your products to get up-to-date product information and find warranty information.

KEYSIGHT SERVICES

Accelerate Technology Adoption.
Lower costs.

Keysight Services

www.keysight.com/find/service

Keysight Services can help from acquisition to renewal across your instrument's lifecycle. Our comprehensive service offerings—one-stop calibration, repair, asset management, technology refresh, consulting, training and more—helps you improve product quality and lower costs.



Keysight Assurance Plans

www.keysight.com/find/AssurancePlans

Up to ten years of protection and no budgetary surprises to ensure your instruments are operating to specification, so you can rely on accurate measurements.

Keysight Channel Partners

www.keysight.com/find/channelpartners

Get the best of both worlds: Keysight's measurement expertise and product breadth, combined with channel partner convenience.

www.keysight.com/find/N6850A

www.keysight.com/find/rfsensor



This information is subject to change without notice.
© Keysight Technologies, 2016 - 2017
Published in USA, December 7, 2017
5992-1237EN
www.keysight.com

B1.3 Moonraker Ltd X1 HF Vertical Receive Antenna Datasheet

Brand: Moonraker UK Limited

Manufacturer's Part Number: 11-510

Part Type: HF Receive Antennas

Product Line: Moonraker Ltd X1 HF Vertical Receive Antennas

DXE Part Number: MKR-11-510

HF Receive Antenna Type: Single whip

Quantity: Sold individually.

Moonraker Ltd X1 HF Vertical Receive Antennas

Moonraker Ltd X1 HF Vertical Receive Antennas are ideal for those who want to listen to shortwave but have limited space to erect larger antennas. This antenna features helical wound, internally loaded wire traps that are a great alternative to a long wire and the RX capabilities range from 1-50 MHz without the need for radials. This antenna is easy to assemble and comes ready to mount to any mast up to 1.50 in. (not included).

Additional Features and Specifications:

- * Antenna Height: 6.562 ft. (200cm)
- * Antenna Connector: UHF SO-239
- * Mast Clamps (included)
- * RG-58 Coax Cable Assembly: 32.808 ft. (10 M) PL-259 to SMA (included)

B1.4 Narda NBM-550 / EA5091 Datasheet

Measuring electric and magnetic fields

ranging from static fields
to microwaves

▲ Non-directional measurement using isotropic probes for applications in the frequency range 0 Hz to 90 GHz



▲ Large, graphic display for easy-to-read results

▲ Intelligent probe interface with automatic detection of probe parameters for simple operation

▲ Memory for up to 5000 measurement results

▲ Automatic storage of position data with GPS interface and plug-in GPS receiver (accessory)

▲ Voice recording for comments

OPTIONAL

▲ Probe for spectral measurements and Weighted Peak from 1 Hz to 400 kHz

▲ Magnetometer Probe for magnetic fields from 0 Hz (DC) to 1 kHz



Narda Broadband Field Meter NBM-550

DESCRIPTION

The Narda Broadband Field Meter NBM-550 is part of the NBM-500 device family. It makes extremely accurate measurements of non-ionizing radiation. Equipped with probes for measuring electric and magnetic field strengths, it covers all frequencies from just a few Hz as found in industrial applications through to long wave and on up to microwave radiation. Flat frequency response probes (“flat probes”), as well as so-called shaped probes that evaluate the field strength on the basis of a human safety standard are available. A probe with built-in FFT analysis enables spectral measurements in the low frequency range. These probes are calibrated separately from the field meter, and include a non-volatile memory that contains the probe parameters and calibration data. They can therefore be used with any device in the NBM-500 family without losing any of the calibration accuracy.

APPLICATIONS

The NBM-550 is used to make precision measurements to establish human safety, particularly in workplace environments where high electric or magnetic field strengths are likely to occur. Some examples are:

- **Measuring field strengths to comply with general safety regulations, such as the EMF Directive 2013/35/EU**
- **Establishing safe zones**
- **Measuring and monitoring field strengths around broadcasting and radar equipment**
- **Measuring field strengths of cell phone transmitters and satellite communications systems to demonstrate compliance with human safety standard limit values**
- **Measuring field strengths in the industrial environment, such as plastics welding equipment, RF heating, tempering, and drying equipment**
- **Measurements for protecting users of diathermy equipment and other medical devices that generate high-frequency radiation**
- **Measuring field strength in TEM cells and absorber chambers to demonstrate electromagnetic compatibility (EMC)**
- **Spectral measurements on LF fields emanating from industrial equipment or overhead power cables**
- **Measuring static magnetic fields in industry and medicine (eg MRT)**



Robust yet light and easy to carry, designed for simple, one-hand operation



Changing the probe is quick and easy, with no need to reconfigure the device

FEATURES with high frequency probes

The Narda Broadband Meter NBM-550 is designed for on-site use. The combined features listed below ensure that it delivers precise results quickly and simply, even under difficult operating conditions.

Display and operation

- Graphical user interface with selectable language.
- Backlit monochrome LCD with selectable illumination time; easy to read, even in bright daylight.

Result display and evaluation

- 5 types of result can be displayed in easy-to-read form: Momentary RMS value (Actual), minimum RMS value (Min), maximum RMS value (Max Hold), average RMS value (Average), maximum average RMS value (Max Avg).
- History Mode memory operates continuously in the background. This allows you to graphically evaluate and save the results for the previous 8 hours of operation (see upper picture opposite).
- Selectable units: V/m, A/m, mW/cm², W/m² when using non-weighted (flat) probes, % of limit value when using weighted (shaped) probes.
- Stored limit values for common human safety standards allow direct display of results for flat probes in % of limit value at a known frequency of the field under test (see lower picture opposite).

Automatic adjustment, application of calibration data

- Intelligent probe interface detects the NBM probe type and automatically recalls and applies the correction values that were recorded during calibration.
- Fully automatic zero point adjustment at programmable time intervals.
- Reminder function lets you know when calibration is due.

Special evaluations

- Time averaging, period settings of up to 30 minutes.
- Spatial averaging, discrete or continuous.
- Multi-position spatial averaging for up to 24 locations.

Warning functions

- Audible warning with programmable alarm threshold.
- Hot spot search function with audible warning.

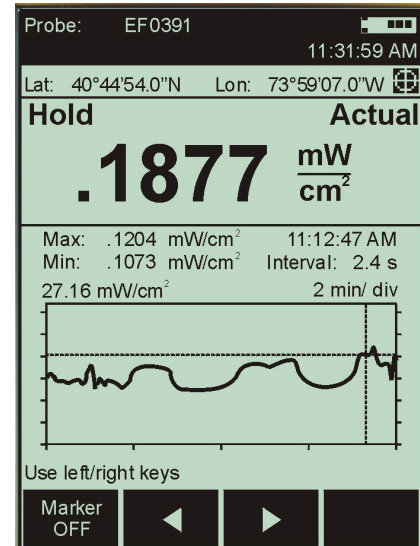

History Mode shows the variation of field strength versus time as a graph. Numerical values can be read out using the marker.

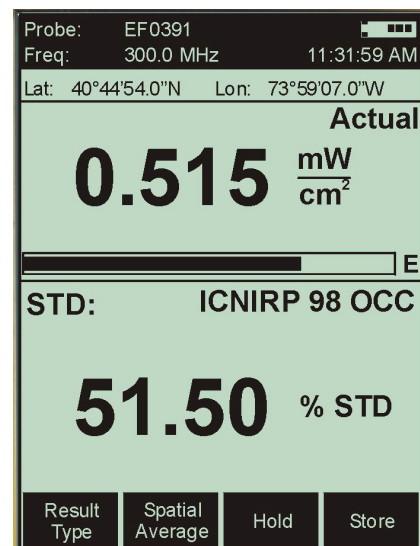

Apply Standard: You can also display the field strength as a percentage of the limit value of a standard even when using flat probes. Simply select the standard on the NBM-550 (ICNIRP in the example shown) and set the frequency. The evaluation is useful if the main component of the field strength is due to a single source of known frequency. Available standards are listed on page 6.

FEATURES with EHP-50F

The EHP-50F FFT analyzer can be conveniently and easily controlled by the Narda Broadband Meter NBM-550 for spectral measurements on low frequency fields. The measured values for the electric or magnetic field are shown on the display of the NBM-550.

Communication between the EHP-50F and the NBM-550 is via an optical cable to avoid affecting the measured field strength. The NBM-550 automatically detects a connected EHP-50F after it is switched on.

Result display and evaluation

- Display modes:
 - Weighted Peak** (WPM) according IEC 61786-2, provides signal weighting in time domain for a selected standard and covers the frequency range from 1 Hz to 400 kHz. Display is in %.
 - Spectrum** mode displays frequency-selective measured RMS values
 - Standard** mode displays the measured RMS values in % referred to the permitted limit value of a selected safety standard
 - XYZ** simultaneously displays the RMS values measured synchronously for the three spatial axes
 - Monitor** for parallel display of the following result types: Momentary RMS value (Actual), minimum RMS (Min), maximum RMS (Max), average RMS (Average)
- Measurement ranges and units:

Electric field:	0.0001 to 100 kV/m
	0.001 to 1000 V/m
Magnetic field:	0.0001 to 10 mT
	0.0001 to 100 μ T
	Results can also be displayed in Gauss
- Frequency range selection in 8 steps
Span (Fstop) = 100/200/500 Hz, 1/2/10/100/400 kHz
- Numerical display of wideband measurement value or the highest value in the spectrum (Highest Peak)

Special evaluations

- Timer controlled measurement with selectable save intervals (Timer Logging)
- Averaging function for 4 / 8 / 16 / 32 samples
- Marker function for evaluating the spectrum graphics and the graphics for Weighted Peak vs. time

Warning functions

- Audible warning variable thresholds separately settable for electric and magnetic field

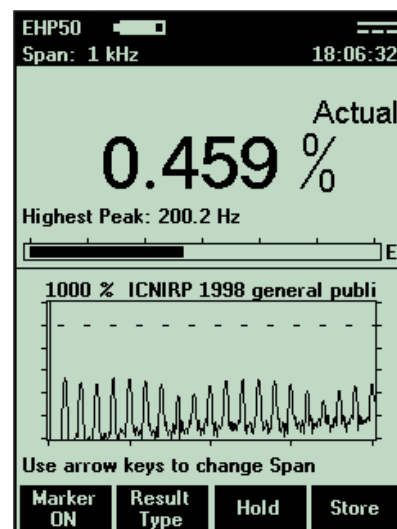

Standard mode displays the spectrum of the measured field, evaluated e.g. according to the ICNIRP guidelines. The dotted line represents the limit value (100%).



NBM-550 with EHP-50F: The perfect solution for all industrial applications.

Operation

- User-defined setups make it easy to recall device settings
- Battery saving user-selectable timed auto-off function
- Hold button “freezes” measurement result for easy readout
- Keypad lock prevents inadvertent operation of control keys

Remote control

- NBM-TS PC software enables remote controlled measurements (EHP-TS should be used for remote control of the EHP-50F)
- PC connection via USB or optical interface
- Additional freedom of movement for probes provided by using an extension and optical cable. The NBM-550 controller function enables data communication with the smaller NBM-520 for use as a “probe extension handle”. This makes it possible to locate the probe remotely from the NBM-550 control unit without the adverse effects on the measurement that would be caused by metallic connecting cables.



Left:
 Probe extension using an optical cable. The NBM-550 acts as controller and displays the results. The smaller NBM-520 acts as the optical probe interface. Both devices can also be used separately as measuring devices when fitted with probes.

Result storage and evaluation

- Data memory for up to 5000 results
- External trigger input for data storage (e.g. for connecting to an odometer)
- Timer Logging for timer controlled data storage (e.g. for long-term monitoring)
- Conditional Logging: Stores measurement data when a threshold value is exceeded when using a high frequency probe
- Screenshot download as bitmap for simple documentation
- “NBM-TS” PC software for convenient data management, documentation and subsequent evaluations

Other functions

- GPS interface and plug-in GPS receiver (accessory) for automatic storage of position data
- Audio recorder for voice comments, with built in microphone, and earphone output; transfer to PC



Above: The battery compartment is opened easily using a coin. Four replaceable NiMH rechargeable batteries (AA size) are used to power the device.

Below:

Open the protective rubber cover to access the connectors: Charger socket, optical interface, headphone connector and the multi purpose GPS / USB/ external trigger connector.



GPS receiver connected to the NBM-550

PC SOFTWARE

The comprehensive, easy to use "NBM-TS" PC software (free download) provides the following functions:

- Result transfer to a PC
- Result database management
- Result evaluations
- Device configuration management
- Firmware update control
- Remote controlled measurements

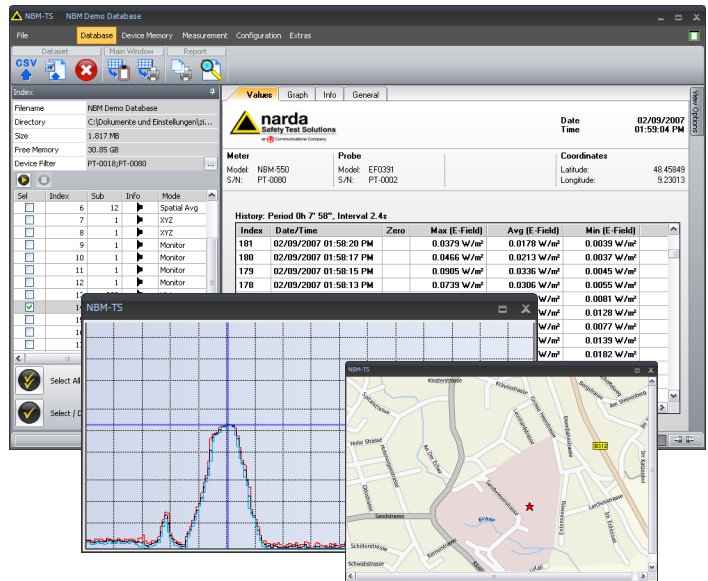

STANDARDS

Safety limits are already stored in the NBM-550 for a variety of standards. In addition, users can also create their own standards. This allows direct display of results for flat probes in % of limit value at a known frequency of the field under test.

Safety Standard	Region	Safety Standard	Region
2013/35/EU Limbs	European Union	ICNIRP 1998 Occupational	International
2013/35/EU High ALs	European Union	ICNIRP 1998 General Pub	International
2013/35/EU Low ALs	European Union	ICNIRP 2010 Occupational	International
BGV B11 2h/d	Germany	ICNIRP 2010 General Pub	International
BGV B11 Area 1	Germany	ICNIRP 2020 Occupational	International
BGV B11 Area 2	Germany	ICNIRP 2020 General Pub	International
EMFV 2016 Low ALs	Germany	IEEE C95.1 2019 Restricted	International
FCC 1997 Occupational	USA	IEEE C95.1 2019 Unrestricted	International
FCC 1997 General Pop	USA	Safety Code 6 2015 Controlled	Canada
GB8702-2014	China	Safety Code 6 2015 Uncontrlid	Canada

APPLICATIONS - HIGH FREQUENCY PROBES

Frequency range	300 kHz to 30 MHz	27 MHz to 1 GHz	100 kHz to 3 GHz	100 kHz to 6 GHz	3 MHz to 18 GHz	40 MHz to 40 GHz	300 MHz to 50 GHz	100 MHz to 60 GHz	100 MHz to 90 GHz	300 kHz* to 50 GHz
Field type	H	H	E	E	E	E	E	E	E	E Shaped
Probe designation	HF3061	HF0191	EF0391 EF0392	EF0691 EF0692	EF1891	EF4091	EF5091	EF6092	EF9091	EA ... ED5091
Mobile radio / telecommunications	●	●	●	●	●					●
Radio / TV broadcasting	●	●	●	●	●					●
Satellite communications					●	●	●	●	●	○
Radar					○	○	●	○	●	○
Industry: Heating and tempering	●		●	●						
Industry: Plastics welding	●		●	●						
Industry: Semiconductor production	○		●	●						
Medicine: Diathermy, hyperthermy			●	●						○
Leak detection					●	●	●	●	●	○
General public safety	●	○	●	●	●	●	○	●	●	○
Health and safety at work	●	●	●	●	●	●	●	●	●	●

*) EB5091: 3 MHz – 50 GHz

● more important

○ variable importance

SPECIFICATIONS

NBM-550													
DISPLAY													
Display type	Transflective LCD, monochrome												
Display size	10 cm (4"), 240 x 320 dots												
Backlight	White LEDs, selectable illumination time (OFF, 5s, 10s, 30s, 60s, PERMANENT)												
Refresh rate	200 ms for bar graph and graphics, 400 ms for numerical results												
Operating languages	English, French, German, Italian, Spanish, Simplified Chinese, Turkish, Russian												
MEASUREMENT FUNCTIONS (with high frequency probes)													
Result units	mW/cm ² , W/m ² , V/m, A/m, % (of standard)												
Display range	.0001 to 9999, 4 digits, variable or fixed triads can be selected <table border="0" style="width: 100%;"> <tr> <td style="width: 50%;"><u>Variable triads</u></td> <td style="width: 50%;"><u>Fixed triads</u></td> </tr> <tr> <td>0.01 V/m to 100.0 kV/m</td> <td>0.01 to 9999 V/m</td> </tr> <tr> <td>0.01 mA/m to 265.3 A/m</td> <td>0.0001 to 265.3 A/m</td> </tr> <tr> <td>0.001 mW/m² to 26.53 MW/m²</td> <td>0.0001 to 9999 W/m²</td> </tr> <tr> <td>0.1 nW/cm² to 2.653 kW/cm²</td> <td>0.0001 to 9999 mW/cm²</td> </tr> <tr> <td>0.0001 % to 9999 %</td> <td>0.0001 to 9999 %</td> </tr> </table>	<u>Variable triads</u>	<u>Fixed triads</u>	0.01 V/m to 100.0 kV/m	0.01 to 9999 V/m	0.01 mA/m to 265.3 A/m	0.0001 to 265.3 A/m	0.001 mW/m ² to 26.53 MW/m ²	0.0001 to 9999 W/m ²	0.1 nW/cm ² to 2.653 kW/cm ²	0.0001 to 9999 mW/cm ²	0.0001 % to 9999 %	0.0001 to 9999 %
<u>Variable triads</u>	<u>Fixed triads</u>												
0.01 V/m to 100.0 kV/m	0.01 to 9999 V/m												
0.01 mA/m to 265.3 A/m	0.0001 to 265.3 A/m												
0.001 mW/m ² to 26.53 MW/m ²	0.0001 to 9999 W/m ²												
0.1 nW/cm ² to 2.653 kW/cm ²	0.0001 to 9999 mW/cm ²												
0.0001 % to 9999 %	0.0001 to 9999 %												
Result types (RMS, isotropic)	Actual, Maximum, Minimum, Average, Average Maximum												
Result types (RMS, X-Y-Z mode)	Actual X, Actual Y, Actual Z (requires a probe with separate axes)												
Time averaging	Selectable averaging time, 4 s to 30 min (2 s steps)												
Spatial averaging	Discrete or continuously												
Multi-position spatial averaging	Averages up to 24 spatially averaged results, each position and total is stored												
History Mode	Graphical display of Actual RMS results versus time (span of 2 minutes to 8 hours)												
Correction frequency	1 kHz to 100 GHz or OFF (direct frequency entry, interpolation between calibration points)												
Hot Spot Search	Audible indication of increasing and decreasing field strength (result type Act or Max)												
Alarm function	2 kHz audible signal (4 Hz repetition), adjustable threshold												
Timer Logging	Start time pre-selection: up to 24 h or immediate start Logging duration: up to 100 h Logging interval: 1s to 6 min (in 11 steps)												
RESULT MEMORY													
Physical memory	12 MB non-volatile flash memory for measurement results and voice comments												
Storage capacity	Up to 5000 results (including instrument settings, time stamp and GPS data when available)												
INTERFACES													
Remote control	Via USB or optical RS-232 interface (selectable)												
USB	Serial, full duplex, 460800 baud (virtual COM port), multi-pin connector												
Optical interface	Serial, full duplex, 115200 baud, no parity, 1 start and 1 stop bit												
Earphone	3.5 mm TRS, ≥ 16 ohms (mono), see accessories												
External trigger (for result storage)	Uses the multi-pin connector. Interface cable with BNC connector available as accessory Triggers when contacts short-circuited												
External GPS receiver	Uses the multi-pin connector; GPS receiver with interface cable available as accessory												
Probe interface	Plug-and-play auto detection, compatible with all NBM series probes RMS integration time for measuring input approx. 270 ms Measurement sampling rate 5 Hz (5/ 50/ 60 Hz for remote operation)												

OTHER FUNCTIONS	
Conditional Logging	
Logging conditions	Selectable, - On upper threshold: Results stored when measurements exceed the adjustable threshold - Out of gap: Results stored when measurements are above the upper threshold or below the lower threshold
Logging range	Selectable, - Store all (as long as the condition is true), sampling rate 5 Hz - Store first and last event (when the condition was true)
Voice Recorder	
Microphone	Built in microphone located at the top of the instrument near the Narda logo
Recording level	Fixed level, VU meter for level monitoring displayed when recording
Recording length	30 s max. length per voice comment, 1 voice comment stored with relevant result
Recording format	8-bit PCM mono, stored as WAV file (approx. 240 kbyte per 30 s)
Output	External earphone (adjustable output level) or via NBM-TS PC software
GPS Position Logging	
	With attached GPS receiver (GPS Kit available as accessory)
Receiver type	GPS Standard Positioning Service and Differential GPS (DGPS) capability using real-time WAAS/EGNOS correction
Displayed position data	Latitude (Lat) and longitude (Long), selectable units: DMS (degrees, minutes, seconds)/ MinDec (decimal minutes)/ DegDec (decimal degrees)
Geodetic system	WGS84/ NAD83
Position accuracy	< 3 m (Differential GPS), <15 m (Standard GPS), high precision mode indicated on the NBM-550. Accuracy specified for 95 % probability
Update rate	1 s
Receiver size/ weight	61 mm diameter x 19.5 mm high / 62 g (approx. 100 g with mounting plate)
Receiver mounting	Uses the tripod thread on underside of device, mounting plate included
GENERAL SPECIFICATIONS	
Recommended calibration interval	24 months (basic unit only, probes are specified separately)
Battery	NiMH rechargeable batteries, 4 x AA size (Mignon), 2700 mAh, included
Operation time	20 hours (backlight off, no GPS) 12 hours (permanent backlight, no GPS) 10 hours (GPS receiver connected, no backlight)
Charging time	2 hours
Battery level display	100%, 80%, 60%, 40%, 20%, 10%, low level (< 5%)
Temperature range	
Operating	-10 °C to +50 °C
Non-operating (transport)	-30 °C to +70 °C
Humidity	5 to 95%, non condensing ≤29 g/m ³ absolute humidity (IEC 60721-3-2 class 7K2)
Immunity to radiated electromagnetic fields	200 V/m (100 kHz to 60 GHz) Note: The immunity may be less than the specified measurement range of a probe
Operation in static magnetic fields	≤ 30 mT (to avoid high force on the device)
Size (h x w x d)	45 x 98 x 280 mm (without probe and GPS receiver)
Weight	550 g (without probe and GPS receiver).
Accessories (included)	Hard case, power supply, rechargeable batteries, shoulder strap, tripod (bench top), USB interface cable, operating manual, certificate of calibration, NBM-TS software (free download)
Country of origin	Germany

This product is protected by the following patents:
 China Design Patent ZL 2006 3 0303322.X
 China Design Patent ZL 2006 3 0190679.1
 European Design Patent 000594254-001
 European Design Patent 000597836-0001
 U.S. Design Patent No. US D570,235 S

U.S. Patent No. 5,877,619
 German Patent DE19536948A1

ORDERING INFORMATION

NBM-550	Part Number (P/N)
NBM-500 Set 1, Narda Broadband Field Meter - Probes are not included - Set includes: - NBM-550 Basic Unit (2401/01B) - Hard case for NBM-500 Series, holds meter and up to 5 probes (2400/90.06) - Power Supply 9VDC, 100V-240VAC (2259/92.06) - Battery, Rechargeable AA-Size, NiMH (4 pcs. 1001-0000-471) - Shoulder Strap, 1m (2244/90.49) - Tripod, bench top, 0.16m (2244/90.32) - Cable, USB Interface for NBM-550, 2 m (2400/90.05) - Operating Manual NBM-550 - Calibration Certificate - Software, NBM-TS, PC Transfer (free download)	2400/101B
NBM-500 Set 13, 1Hz-6GHz with EHP-50F, NBM-550, EF0691 Set includes: - all parts from NBM-500 Set 1 (2400/101B) - all parts from EHP-50F E&H Field Analyzer Set, 1Hz-400kHz (2404/103) - Probe EF 0691, E-Field, 100kHz-6GHz (2402/14B) - Tripod, Non-Conductive, 1.65m, with Carrying Bag (2244/90.31)	2400/113
NBM-500 Set 15, 1Hz-3GHz with EHP-50F, NBM-550, EF0391 Set includes: - all parts from NBM-500 Set 1 (2400/101B) - all parts from EHP-50F E&H Field Analyzer Set, 1Hz-400kHz (2404/103) - Probe EF 0391, E-Field, 100kHz-3GHz (2402/01B) - Tripod, Non-Conductive, 1.65m, with Carrying Bag (2244/90.31)	2400/115
GPS Kit	See Accessories
HIGH FREQUENCY PROBES *	
Probe HF 3061, H-Field, for NBM, 300kHz-30MHz	2402/05B
Probe HF 0191, H-Field, for NBM, 27MHz-1GHz	2402/06B
Probe EF 0391, E-Field, for NBM, 100kHz-3GHz	2402/01B
Probe EF 0392, E-Field, HiPow, for NBM, 100kHz-3GHz	2402/12B
Probe EF 0691, E-Field, for NBM, 100kHz-6GHz	2402/14B
Probe EF 0692, E-Field, for NBM, 600MHz-6GHz	2402/20B
Probe EF 1891, E-Field, for NBM, 3MHz-18GHz	2402/02B
Probe EF 4091, E-Field, for NBM, 40MHz-40GHz	2402/19B
Probe EF 5091, E-Field, for NBM, 300MHz-50GHz, Thermo.	2402/03D
Probe EF 6092, E-Field, for NBM, 100MHz-60GHz	2402/17B
Probe EF 9091, E-Field, for NBM, 100MHz-90GHz	2402/18B
Probe EA 5091, FCC 1997 Controlled Shaped for NBM, 300 kHz - 50 GHz, E-Field	2402/07D
Probe EB 5091, IEEE 2019 Restricted Shaped for NBM, 3 MHz - 50 GHz, E-Field	2402/21B
Probe EC 5091, SC 6 2015 Controlled Shaped for NBM, 300 kHz - 50 GHz, E-Field	2402/16D
Probe ED 5091, ICNIRP 1998 Occ Shaped for NBM, 300 kHz - 50 GHz, E-Field (compliant with ICNIRP 2020 above 30 MHz)	2402/10D

* See separate data sheets for probe specifications

LOW FREQUENCY PROBE *

EHP-50F E&H Field Analyzer Set, 1Hz-400kHz, for NBM-550

Set Includes:

- EHP-50F Basic Unit (2404/03)
- AC/DC Battery Charger, for EHP-50 (2259/92.08)
- Cable, FO Duplex, RP-02, 10m (2260/91.07)
- Optical Bridge Connector RP-02 (2260/91.08)
- EHP-TS PC Software (2404/93.01)
- O/E Converter USB, RP-02/USB (2260/90.07)
- Tripod Extension, 0.50m, Non-Conductive (2244/90.45)
- Foam Inserts for EHP-50, for Hardcase 2400/90.06 (2404/90.01)

2404/103**DC MAGNETOMETER PROBE ***

HP-01 Magnetometer Set DC-1kHz

Includes:

- HP-01 Basic Unit
- Zero Gauss Chamber
- AC/DC Battery Charger
- Cable, FO Duplex (1000 μ m) RP-02, 10 m
- Cable, FO Duplex (1000 μ m) RP-02, 25 cm
- O/E Converter USB, RP-02/USB
- Conical Tripod Support
- HP-01 / NBM Adapter
- Software CDROM including User's Manual
- Certificate of Calibration
- Carrying Case

**2405/101****ACCESSORIES**

GPS Kit for NBM-550, Receiver and Mounting Set	2400/90.10
Earphone, 3.5mm Plug	2400/90.03
Test-Generator 27 MHz	2244/90.38
Tripod, Non-Conductive, 1.65m, with Carrying Bag	2244/90.31
Tripod Extension, 0.50m, Non-Conductive (for 2244/90.31)	2244/90.45
Handle, Non-Conductive, 0.42m	2250/92.02
Cable, Coaxial Multi-pin/ BNC, for NBM-550, Ext. Trigger, 2m	2400/90.04
Cable, FO Duplex (1000 μ m) RP-02, 2 m	2260/91.02
Cable, FO Duplex (1000 μ m) RP-02, 5 m	2260/91.09
Cable, FO Duplex (1000 μ m) RP-02, 10 m	2260/91.07
Cable, FO Duplex (1000 μ m) RP-02, 20 m	2260/91.03
Cable, FO Duplex (1000 μ m) RP-02, 50 m	2260/91.04
Cable, FO Duplex, F-SMA to RP-02, 0.3 m	2260/91.01
O/E Converter RS232, RP-02/DB9	2260/90.06
O/E Converter USB, RP-02/USB	2260/90.07
Cable, Adapter USB 2.0 - RS232, 0.8 m	2260/90.53

Narda Safety Test Solutions GmbH
 Sandwiesenstrasse 7
 72793 Pfullingen, Germany
 Phone +49 7121 97 32 0
 info@narda-sts.com

Narda Safety Test Solutions
 North America Representative Office
 435 Moreland Road
 Hauppauge, NY11788, USA
 Phone +1 631 231 1700
 info@narda-sts.com

Narda Safety Test Solutions S.r.l.
 Via Rimini, 22
 20142 Milano, Italy
 Phone +39 0258188 1
 nardait.support@narda-sts.it

Narda Safety Test Solutions GmbH
 Beijing Representative Office
 Xiyuan Hotel, No. 1 Sanlihe Road, Haidian
 100044 Beijing, China
 Phone +86 10 6830 5870
 support@narda-sts.cn

www.narda-sts.com

© Names and Logo are registered trademarks of Narda Safety Test Solutions GmbH - Trade names are trademarks of the owners.



Measuring electric fields with shaped frequency response up to 50 GHz

using instruments in the NBM-500 family

- ▲ **Frequency shaping to match the ICNIRP, FCC, IEEE or Safety Code 6 standard for occupational/ controlled environment**
- ▲ **Results are directly displayed in “% of Standard”**
- ▲ **Precise results without the need to know the emitted frequency**
- ▲ **Isotropic (non-directional) measurements**

The probes contain 6 dipoles, three diode based and three thermocouple based dipoles. The correctly tuned overlap of two dipoles, one acting as a high pass filter the other as a low pass filter, provides a frequency sensitivity that mirrors a particular standard. Testing for compliance to that standard is very easy to perform, since you no longer have the need to know the emitted frequency.

APPLICATIONS

Electric fields from 300 kHz to 50 GHz (3 MHz to 50 GHz with EB 5091) can be detected. The probes are particularly suitable for measuring human safety limit values in mobile phone, telecom transmitter and broadcasting environment.

CALIBRATION

The probes are calibrated at several frequencies. The correction values are stored in an EPROM in the probe and are automatically taken into account by the NBM instrument. Calibrated accuracy is thus obtained regardless of the combination of probe and instrument.



DESCRIPTION - Shaped Probes

The goal in designing and manufacturing a traditional, “flat” frequency response probe is to make the probe equally responsive to energy at every frequency within its rated frequency range. In contrast, Narda’s patented shaped frequency response probes are designed and manufactured so that their sensitivity mirrors a particular standard (or guidance) as closely as possible.

For example, many of the major guidances and standards in the world set E-field limits for maximum human exposure at 614 V/m (1000 W/m²) at lower frequencies (~1 MHz). At frequencies of 30 to 300 MHz the limits are typically much less, 61.4 V/m (10 W/m²), a difference of 20 dB (100 times the power). A shaped frequency response probe designed for such limits is 100 times more sensitive in the 100 MHz region, than at 1 MHz.

If you were performing a survey of a site with a flat frequency response probe that has both of the above frequency ranges and your survey indicated 137 V/m (or 50 W/m²), it would be difficult to determine if the site was out of compliance without turning one of the emitters off. Again, given the example above, the site could be generating anywhere from 5% to 500% of the human exposure limit. There are many sites with multiple emissions (rooftops, flight lines, broadcast towers) that have emitters at different exposure limits.

If your interest is general safety measurements, to know if you comply with an exposure limit or not, you will find shaped probes easy to use in any environment. The display of total field strength with shaped probes is not in terms of V/m or W/m², it is “% of Std.” So at a multiple emitter site, a result of 15% is simple to understand. The total detected field strength of each emitter (to its limit, at its frequency) has added up to 15%. Besides the ease of use, the main advantage is that you no longer have the “need to know” the frequency when using a shaped probe.

Table: Standards and matching probe models

Standard or Guidance	Level	Model
U.S. FCC, 1997	Occupational/ Controlled	EA 5091
IEEE C95.1-2019	Controlled Environments	EB 5091
Canada Safety Code 6, 2015	Controlled Environments	EC 5091
ICNIRP 1998 Guidelines compliant with ICNIRP 2020 above 30 MHz	Occupational	ED 5091

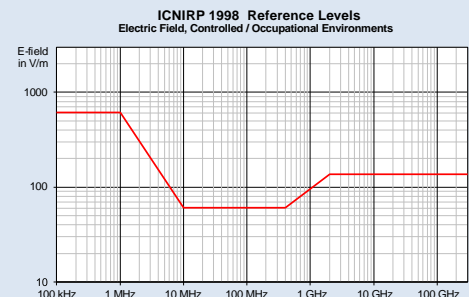
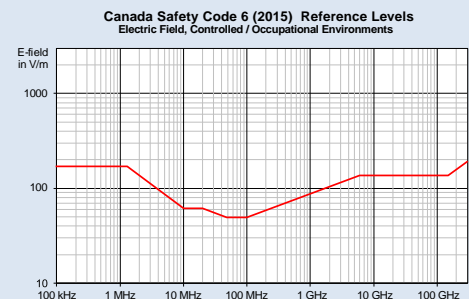
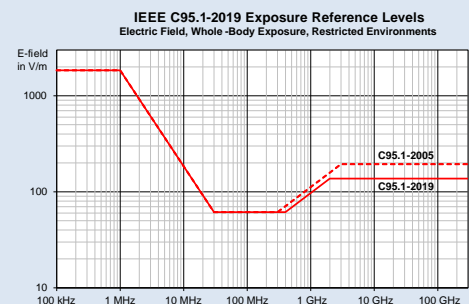
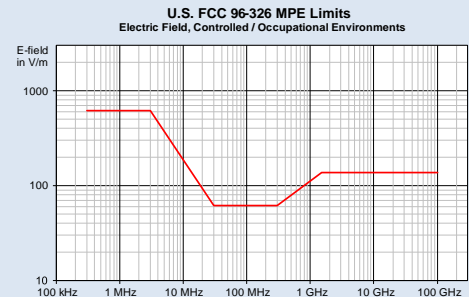

SPECIFICATIONS ^a

Probe EA ... ED 5091		Electric (E-)Field	
Frequency range ^(b)	300 kHz to 50 GHz (IEEE Model: 3 MHz to 50 GHz)		
Type of frequency response	Shaped, see table on page 2		
Measurement range	0.5 to 600 % of Standard (Power Density)		
Dynamic range	30 dB		
CW damage level	2000 % of Standard	700 mW/cm ²	
Peak damage level ^(c)	32 dB above Standard		
Sensor type	Combined diodes/ thermocouples		
Directivity	Isotropic (Tri-axial)		
Readout mode / spatial assessment	Combined 3-axis (RSS)		
UNCERTAINTY			
Flatness of frequency response ^(d) Calibration uncertainty not included	±2 dB from Standard		
Linearity Referred to 100 %	±3 dB (< 4 % of Standard)		
	±1 dB (4% to 12 % of Standard)		
	±0.5 dB (12 % to 600 % of Standard)		
Isotropic response ^(e)	±1 dB (10 MHz to 5 GHz) typ. ±1.5 dB (> 5 GHz)		
Temperature response	typ. ±0 dB (≥ 2 GHz)		
GENERAL SPECIFICATIONS			
Calibration frequencies	0.3/ 3/ 10/ 30/ 100/ 300/ 750 MHz 1/ 1.8/ 2.45/ 4/ 8.2/ 10/ 18/ 26.5/ 40/ 45.5 GHz		
Recommended calibration interval	24 months		
Temperature range	Operating	0 °C to +50 °C	
	Non-operating	-40 °C to +70 °C	
Humidity	5 to 95 % RH @ ≤25 °C		≤23 g/m ³ absolute humidity
Size	350 mm x 104 mm Ø		
Weight	240 g		
Compatibility	NBM-500 series meters		
Country of origin	Germany		

- (a) Unless otherwise noted specifications apply at reference condition: device in far-field of source, ambient temperature 23±3 °C, relative air humidity 40% to 60%, sinusoidal signal
(b) Cutoff frequency at approx. -3 dB
(c) Pulse length 1µsec, duty cycle 1:1000
(d) Frequency response can be compensated for by the use of correction factors stored in the probe memory
(e) Results are calculated from the maximum and minimum response obtained during the full revolution about the stem of the probe, oriented 54.7° to the electric field vector.

ORDERING INFORMATION

	Part number P/N
Probe EA 5091, FCC 1997 Controlled Shaped for NBM, 300 kHz - 50 GHz, E-Field	2402/07D
Probe EB 5091, IEEE 2019 Restricted Shaped for NBM, 3 MHz - 50 GHz, E-Field	2402/21B
Probe EC 5091, SC 6 2015 Controlled Shaped for NBM, 300 kHz - 50 GHz, E-Field	2402/16D
Probe ED 5091, ICNIRP 1998 Occ Shaped for NBM, 300 kHz - 50 GHz, E-Field (compliant with ICNIRP 2020 above 30 MHz)	2402/10D
Probe ED 5091, ICNIRP 1998 Occ Shaped, ACC - with accredited (DAkKS) calibration up to 18 GHz, basic unit required	2402/10D/ACC

Narda Safety Test Solutions GmbH
Sandwiesenstrasse 7
72793 Pfullingen, Germany
Phone +49 7121 97 32 0
info@narda-sts.com

Narda Safety Test Solutions
North America Representative Office
435 Moreland Road
Hauppauge, NY11788, USA
Phone +1 631 231 1700
info@narda-sts.com

Narda Safety Test Solutions S.r.l.
Via Rimini, 22
20142 Milano, Italy
Phone +39 0258188 1
nardait.support@narda-sts.it

Narda Safety Test Solutions GmbH
Beijing Representative Office
Xiyuan Hotel, No. 1 Sanlihe Road, Haidian
100044 Beijing, China
Phone +86 10 6830 5870
support@narda-sts.cn

www.narda-sts.com

© Names and Logo are registered trademarks of Narda Safety Test Solutions GmbH - Trade names are trademarks of the owners.

B1.5 Narda SRM-3000 Datasheet



Advanced Test Equipment Rentals
www.atecorp.com 800-404-ATEC (2832)



SELECTIVE RADIATION METER SRM-3000



**FREQUENCY-SELECTIVE, ISOTROPIC
MEASUREMENT, EVALUATION, AND RECORDING OF
HIGH FREQUENCY ELECTROMAGNETIC FIELDS**

Narda Safety Test Solutions GmbH

Sandwiesenstrasse 7
72793 Pfullingen, Germany
Phone: +49 (0) 7121-97 32-777
Fax: +49 (0) 7121-97 32-790
E-mail: support@narda-sts.de
www.narda-sts.de

Narda Safety Test Solutions

435 Moreland Road
Hauppauge, NY 11788, USA
Phone: +1 631 231-1700
Fax: +1 631 231-1711
E-mail: NardaSTS@L-3COM.com
www.narda-sts.com

Narda Safety Test Solutions Srl

Via Leonardo da Vinci, 21/23
20090 Segrate (Milano), Italy
Phone: +39 02 2699871
Fax: +39 02 26998700
E-mail: support@narda-sts.it
www.narda-sts.it

NSTS 0307-E0211C Technical advances, errors and omissions excepted



TELECOMMUNICATION IS EVERYWHERE. SELECTIVE MEASUREMENT

Total coverage with radio, TV and mobile phone services also means total coverage with electromagnetic radiation. To prevent any damaging effects on humans and their environment, all industrialized countries have specified immission limit values. These are mostly based on the recommendations made by the International Commission for Non-Ionizing Radiation Protection (ICNIRP), which is a body recognized as a non-governmental radiation protection organization by the World Health Organization (WHO) and the Council of Europe (EU). In many countries, the limit values for sensitive areas such as kindergartens, schools, and hospitals are even lower.

Limit values are only useful if they are kept to. The responsible authorities have to keep a check on things. That's their job. They can contract it out to measurement service providers. Quite often, communities, action groups, works councils, and even private persons will ask a measuring service or a building ecologist to

check the electromagnetic radiation situation at a particular location. The results can be confusing, since radio, TV, pagers, police and emergency services, mobile phones – from GSM to UMTS – are all putting out their part.

A broadband measurement only lets you see the overall picture. It won't tell you the difference between contributions to the overall radiation level made by individual sources such as the GSM-900 and GSM-1800 mobile phone services. And most broadband test sets are not sensitive enough to measure these – usually low level – individual sources. So it would be next to impossible to detect an unknown source such as an illegal video monitor. High sensitivity, frequency-selective measuring equipment is therefore essential.

There used to be only two ways to measure and evaluate: broadband, which is quick and easy, or selective, which is slow and complicated. Now there's a third option: fast and selective. Narda has the solution.



Advanced Test Equipment Rentals
www.atecorp.com 800-404-ATEC (2832)

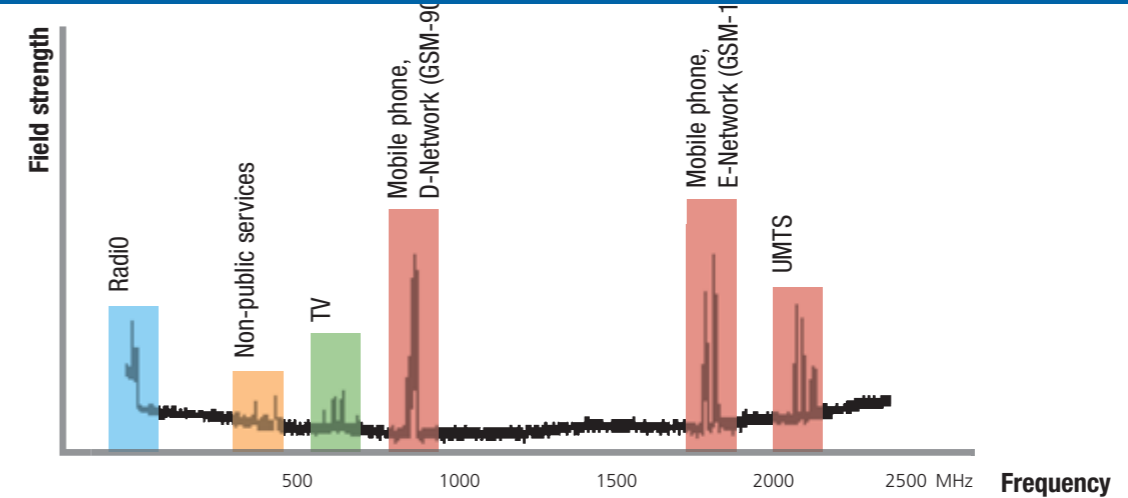

Typical field strength scenario in an urban environment

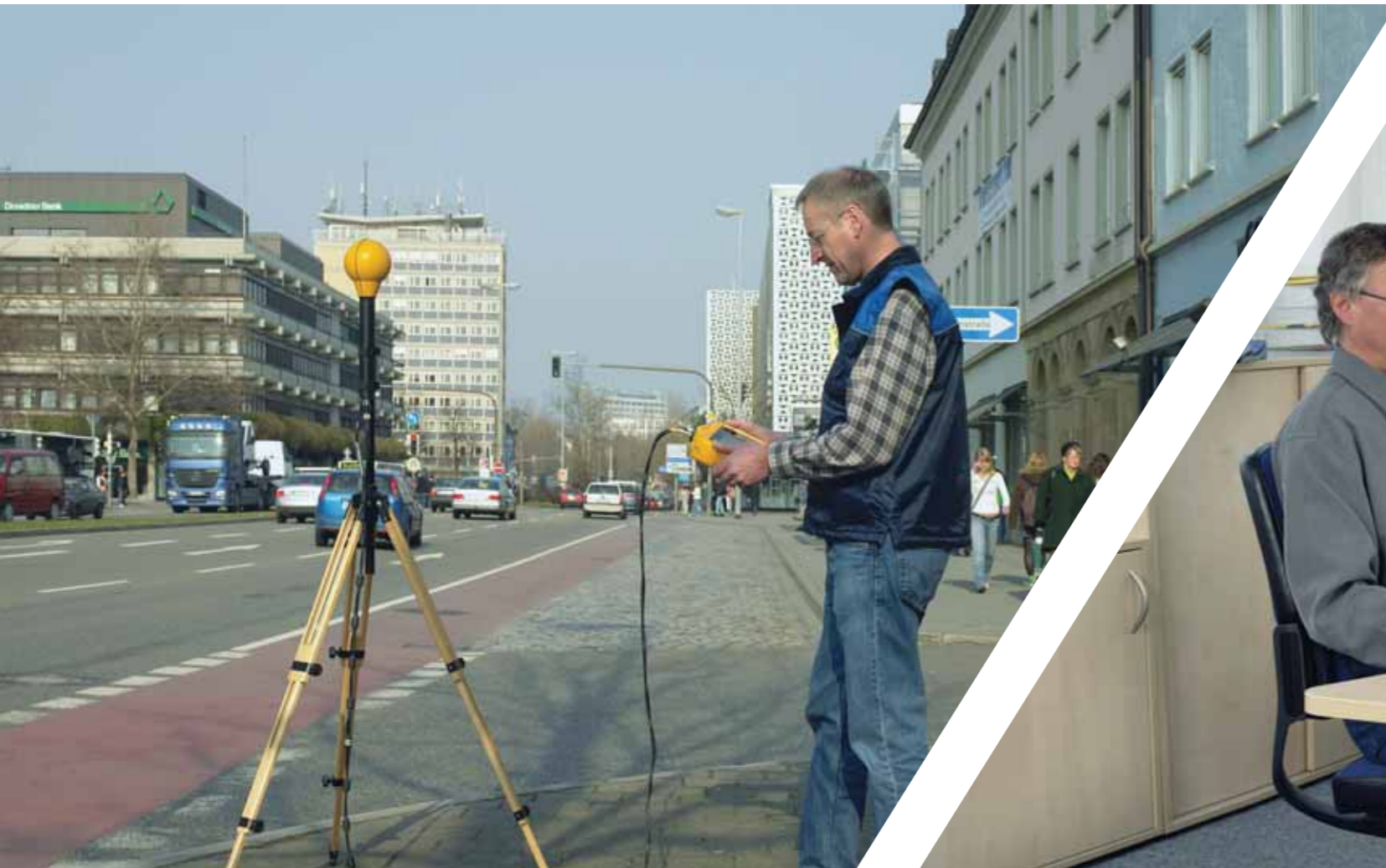

SELECTIVE.

You can't hear electromagnetic radiation. If you could, there would be music in the air. On some rooftops, there are whole choirs and orchestras of antennas. Are they too loud? Do some stand out as soloists?

Test equipment that captures the whole frequency spectrum measures the total radiation level. That's good enough, if the permitted immission limit value is not exceeded.

But what if it is? Then you need to find the reason. A frequency-selective test set is the answer. It separates the GSM choir from the VHF orchestra, identifies the loudest "voices" individually and shows their field strengths. And, if it's sensitive enough, it will also tell you who is humming away in the background.

THE SRM FROM NARDA. FREQUENCY-SELECTIVE. HIGHLY SENSITIVE.

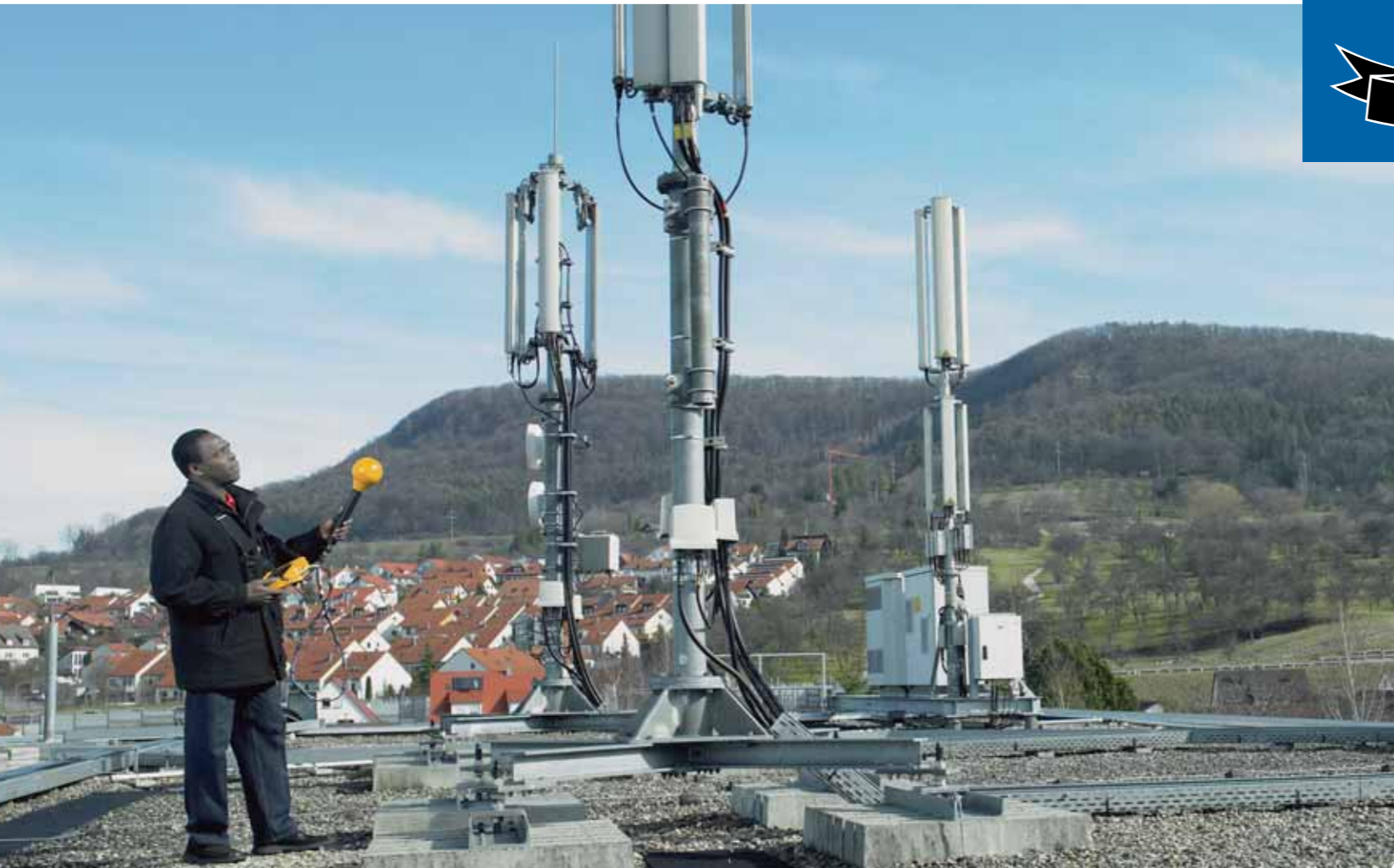

A FOREST OF ANTENNAS. NON-DIRECTIONAL MEASUREMENT HELPS YOU SEE CLEARLY. ALL ROUND.

There's not much space left on some rooftops, thanks to the rising need for communications. That doesn't just apply to the space required for transmitter antennas. There's also not a lot of room to maneuver when it comes to electromagnetic immission limits. These limits fall into two categories.

People who routinely work in high frequency fields are usually properly trained, aware of the dangers, and informed about the regulations governing the length of time they may be exposed to such fields. The permitted limit value for occupational safety is therefore somewhat higher than that prescribed for the general public. This lower limit also applies to casual labor, tradesmen, and visitors who are untrained but who are nevertheless exposed to high frequency fields.

What happens when the limit is exceeded? Well, then the awkward question arises: Who needs to reduce output power? And, by how much?

For a start, both operators and authorities want to know where the major components of the electromagnetic radiation are coming from. It's not only the antennas you can see that are playing a part. Sometimes you just can't see the wood for the trees – radio broadcasters with a wide range, or hidden services located nearby can also have a share.

Measurement services can use a broadband orientation measurement to locate the so-called hot spots, areas where the field strength is highest. If the immission limit is exceeded, the measurement service needs to separate out and measure the known sources such as VHF radio and particular mobile phone services. This can only be done with a selective measurement in the relevant frequency ranges. Narda has the solution for this, too.

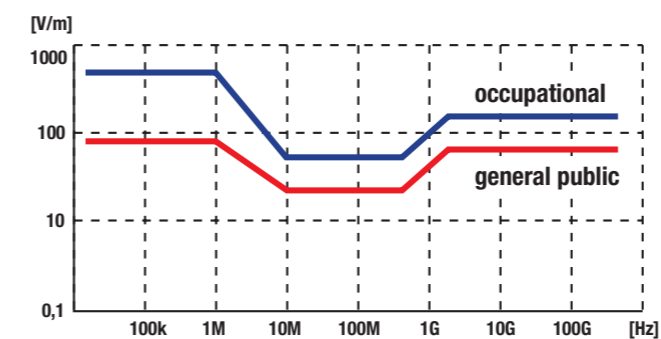

Limit values for electric field strength according to ICNIRP, 1998, for areas accessible to the general public and for higher exposure occupational (workplace) areas.

ISOTROPIC.

You can't see electromagnetic radiation. Even so, it behaves in much the same way as visible light.

Rod antennas radiate in a circular pattern in one plane, sector antennas illuminate a certain angle, and concave reflectors send out a focused beam.

Measuring antennas are similar. A unidirectional antenna only has two "eyes" – one lobe on each side. That's no use if they're both looking in the wrong direction to see the transmitter.

Only an isotropic, i.e. non-directional antenna can see the whole panorama. Naturally, you shouldn't stand in the light when making the measurement!

THE SRM FROM NARDA. NON-DIRECTIONAL. IN THE PALM OF YOUR HAND.

SERVICES, CHANNELS. SELECTIVE MEASUREMENT SORTS OUT THE SPOT.

Wherever you are, you're seldom alone. Many operators make use of common facilities or at least use the same location to provide the services required by their customers. If there's any dispute, each one will want to be able to show how much their transmitter is contributing to the overall field exposure. That's impossible with a simple, broadband measurement. For that to work, the operator would need to be the only one present, or the effects of other services would have to be negligible. And, the transmitter would have to output full power on all channels to generate the maximum level of electromagnetic radiation. The answer here is a selective measurement that detects every output frequency used, and every occupied channel separately, and displays the corresponding field strengths. Intelligent instruments can also integrate over the frequency range of a particular service and display the result, either as an absolute value or as a percentage of the permitted limit value. There's another, clever way to check out GSM: you can selectively measure one or all of the control channels, which always transmit at full power, and calculate the field strength that would occur if all voice channels were running at full load too.

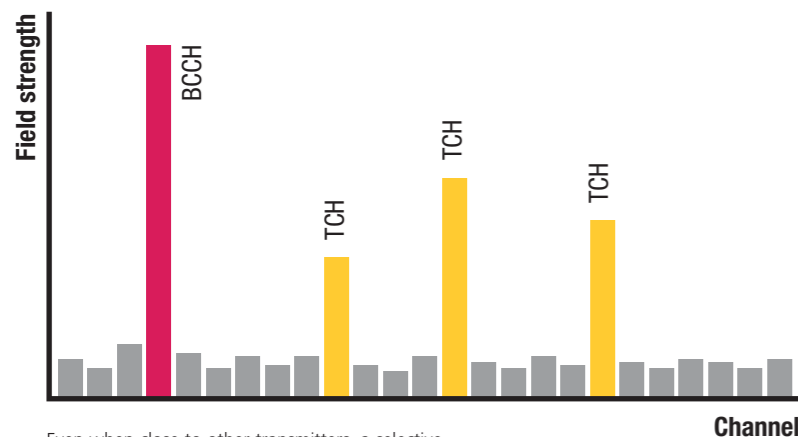

Even when close to other transmitters, a selective test set can detect individual mobile phone channels. This is a typical GSM channel map with 200 kHz between channels. BCCH is the control channel, TCH signifies voice channels each carrying up to eight calls simultaneously.

A similar method can be used for UMTS. At off-peak times, you can measure a frequency block and calculate the overall exposure on the assumption that only the pilot channel was operating. Whatever the method, the test equipment must have the matching bandwidths, adjustable to individual channels, channel groups, or entire frequency blocks. Narda has the solution.

LONG TERM MONITORING

How does the field strength of your own service or the irradiation from a neighboring medium wave transmitter vary during the day? Recording all the measured values or all values above a given threshold level together with a timestamp makes it easy to trace long term trends.



Advanced Test Equipment Rentals
www.atecorp.com 800-404-ATEC (2832)



RADIATION PROOF.

You can't feel electromagnetic radiation.

Mechanical robustness is easy to assess, by taking an object in your hands. Resistance to electromagnetic radiation can only be shown by measurement.

The field strength emanating from a radio broadcast antenna can be ten thousand times more than that from a mobile phone channel – a real challenge for any test set. It needs to be highly sensitive on the one hand, yet on the other hand, strong radiation must not be able to bypass the test antenna and enter the electronic circuits directly, leading to wrong results or even impaired function.

THE SRM FROM NARDA. MEASURES ANYWHERE. RADIATION PROOF.

SRM – SELECTIVE RADIATION METER. GET TO GRIPS WITH THIS

Selective and complicated, or quick and easy broadband? No need to make this choice any longer. The SRM measures selectively and gives you reliable results. Without additional cables or an external PC. We at Narda have designed it especially for the safety concerns in electromagnetic fields. So it's handy, battery operated, and radiation proof, and you can take it anywhere. It has an isotropic measuring antenna, so you don't have to worry about where the radiation is coming from.

It detects everything in the frequency range from VHF to UMTS. For measurements in the mobile phone range, which are most often needed, just pick it up and measure.

It evaluates the measured field strength according to applicable regulations and presents the results just the way you want – ideal for telecoms and mobile phone providers, measurement services, and authorities.

- Choice of field strength or power density units, or as a percentage of the permitted limit value.
- For a single source or an individual channel.
- As a list of sources or channels.
- As a proportion due to a telecommunication service.
- As the proportion due to all services and their percentage contribution to the overall field exposure level.



Advanced Test Equipment Rentals
www.atecorp.com 800-404-ATEC (2832)



The SRM for safety-related analysis of electromagnetic fields. Complete. You can also use it as a fully-fledged spectrum analyzer for field strength measurements unrelated to human safety issues.



The SRM's isotropic measuring antenna detects the electric field strength in all directions equally. Alternatively, you can use single-axis measuring antennas from Narda, or your own measuring antennas.

The SRM takes care of the rest. Immediately. Wherever you are. Without cables or computers. You can, of course, upload the results to a PC, using the SRM's built in RS 232 and USB ports.

REVOLUTION:

A selective measuring instrument especially designed for safety related concerns in electromagnetic fields.

**THE SRM FROM NARDA.
FOR FREQUENCY-SELECTIVE,
NON-DIRECTIONAL MEASUREMENTS.
IN THE PALM OF YOUR HAND, ANYWHERE.**

SRM – SELECTIVE RADIATION METER. DO EVERYTHING. ON THE



Advanced Test Equipment Rentals
www.atecorp.com 800-404-ATEC (2832)

Narda has achieved a breakthrough with the SRM: A frequency-selective, precision measuring instrument that is operated just like a simple, broadband, hand-held tester. That saves time.

The SRM is especially designed for safety related concerns in electromagnetic fields. That means you can take it into any field environment, without having to carry additional cables, power supplies or even a PC. And there's no need to worry about excessive field strengths.

Especially designed for safety related concerns in electromagnetic fields also means that anyone can use the instrument, as no specialist background knowledge is needed.

Safety in electromagnetic fields can only be guaranteed if the measurement results are sound. The SRM is a precision instrument, so it always delivers reliable results. Because it is a special device for safety measurements, it also reduces an often underestimated uncertainty factor: Improper operation and errors in evaluation.

Safety in electromagnetic fields: The SRM gives you the answers immediately, on the spot. No need to go back to the office and work out the results.

These are features you can also take advantage of, even when you "only" use the SRM as a spectrum analyzer for field strength measurements.

**APPLICATION:
ANALYSIS FROM VHF TO UMTS.**

Equipped with an isotropic measuring antenna, the SRM works in the frequency range from 75 MHz to 3 GHz. It thus covers all services from VHF radio up to UMTS. Using other antennas, it can measure down to 100 kHz, so it can cover the entire broadcasting spectrum from long wave up.

The resolution (RBW) can be set to match the service you are measuring, such as 1 kHz for long wave, 200 kHz for the GSM channel map or 5 MHz for a complete UMTS frequency block.

**TECHNOLOGY:
HIGH SENSITIVITY, RADIATION PROOF.**

The SRM's sensitivity is more than enough to measure individual GSM channels, even indoors, and to reliably demonstrate compliance to limit values of a few Volts per meter in sensitive areas. And if you're standing right next to a strong medium wave transmitter or a VHF repeater and measuring other services, you won't have a problem. The SRM can withstand fields in excess of 200 V/m.

**OPERATION:
COULDN'T BE EASIER. SAFE AND SURE.**

It's not easy to upset the SRM. Just hang it over your shoulder, and off you go – in the heat of summer (up to 50 °C), in ice and snow (down to -10 °C), through mist and fog (up to 95 % humidity). It will even put up with water splashes and a bit of condensation. Use it with the carry strap, and you can operate it with one hand, and call up test setups at the press of a button. You don't have time to make complicated settings when you're up an antenna mast. But you do want reliable results. The SRM delivers.

**CONCEPT:
FLEXIBLE FOR EVERY APPLICATION.**

The SRM is based on an open concept. So, you can upload new standards and evaluation curves for safety measurements as they are published. But not just that: future applications can also make use of its superb performance as a spectrum analyzer.



We haven't re-invented the wheel. We just make use of its best features. Just turn the control to scan through resolution and frequency settings instead of entering rows of figures. Scan through lists of results instead of fiddling with a cursor. There's no faster way to get results.

Frequency range of basic unit	100 kHz to 3 GHz
Resolution bandwidths (RBW)	1 kHz to 5 MHz
Sweep time for one spectrum	50 ms to 1 s, depending on frequency span, measurement in one axis direction
Memory size	Holds up to 9999 data sets
Operating time	Typically 4 hours from fully charged batteries
Weight of basic unit	1.9 kg including batteries

SRM: The major specifications of the basic unit. See page 18 for measurement antennas.

EVOLUTION:

There's no mistaking the origins of Narda's family of instruments. The SRM is precision measurement technology in a workday package. High tech inside, rugged and simple outside. Just switch on and measure – and get reliable results.

**THE SRM FROM NARDA.
EASY, FAST, PRECISE MEASUREMENTS.
IN THE PALM OF YOUR HAND, ANYWHERE.**

OPERATING MODES. FOR EVERYDAY MEASUREMENT SITUATIONS

All the measurements are aimed at safety in electro-magnetic fields. And that's why the first operating mode is called Safety Evaluation.

SAFETY EVALUATION

Everything is prepared for measurement and evaluation. Simply select the services you want to measure, and the regulations you want to use as standards. Or start an overview measurement of the entire frequency range. The SRM does the rest. Automatically. You don't need to be concerned about frequency span, RBW and sweep time, especially if measuring electro-magnetic fields is only a part of your job of measuring environmental pollution such as gases or noise. For expert users, there's another operating mode: Spectrum Analysis.

Service	Value	Frequency	Sel. Srv
FM-Radio	10.49 $\mu\text{W}/\text{m}^2$	87.500 MHz to 108.000 MHz	Sel. last
Mid Wave	1.844 $\mu\text{W}/\text{m}^2$	137.000 MHz to 165.000 MHz	service
Paging	438.6 $\mu\text{W}/\text{m}^2$	165.000 MHz to 174.000 MHz	Sel. all services
Band III (DVB-T)	2.176 $\mu\text{W}/\text{m}^2$	174.000 MHz to 230.000 MHz	Meas. Range
Trains	25.98 $\mu\text{W}/\text{m}^2$	467.450 MHz to 480.300 MHz	Result type
Band IV (DVB-T)	4.378 $\mu\text{W}/\text{m}^2$	470.000 MHz to 790.000 MHz	
Band V (DAB)	729.4 $\mu\text{W}/\text{m}^2$	790.000 MHz to 862.000 MHz	
GSM-R	50.11 $\mu\text{W}/\text{m}^2$	876.000 MHz to 890.000 MHz	
GSM-900	57.83 $\mu\text{W}/\text{m}^2$	890.000 MHz to 960.000 MHz	
L-Band (DAB)	508.0 $\mu\text{W}/\text{m}^2$	1452.000 MHz to 1492.000 MHz	
GSM-1800	55.87 $\mu\text{W}/\text{m}^2$	1710.000 MHz to 1880.000 MHz	
Total	180.0 $\mu\text{W}/\text{m}^2$	87.500 MHz to 2500.000 MHz	
Isotropic Result			
Fmin:	87.5 MHz	Process Time:	1.859 s
Fmax:	2.5 GHz	No. of Runs:	17
RBW:	200 kHz(Auto)	Result:	MAX

SAFETY EVALUATION

Unknown or unclear field environment? The SRM automatically shows the overall field exposure (Total) as well as the contributions made by individual services.

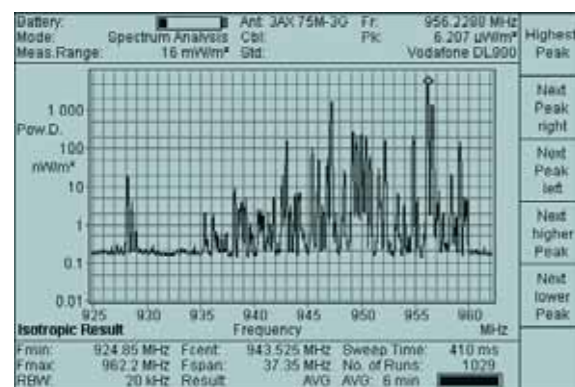

SPECTRUM ANALYSIS

Classic spectrum display with extra features: Peak marker lets you read off individual values. And the field strength values can be integrated over a variable frequency range.

SPECTRUM ANALYSIS

This lets you use the SRM just like a spectrum analyzer. If you want to know how the field varies over a longer period of time, choose another mode: Time Analysis.

TIME ANALYSIS

In this operating mode you can make narrow bandwidth measurements and show the results graphically or numerically. Resolution bandwidths between 1 kHz and 6 MHz, variable averaging time, RMS or peak value detector.

Index	Frequency	Peak Level	Service
1	104.8029 MHz	0.0000615 μV	Sunshine
2	92.2011 MHz	0.0000367 μV	SWK 3
3	90.1009 MHz	0.0000219 μV	SWR 4 BW
4	94.6999 MHz	0.0000155 μV	SWR 1
5	105.7007 MHz	0.0000142 μV	
6	102.3000 MHz	0.0000077 μV	
7	89.4997 MHz	0.0000052 μV	Big FM
8	103.1010 MHz	0.0000051 μV	
9	101.3002 MHz	0.0000020 μV	HitzRAD Antenne1
10	90.7991 MHz	0.0000013 μV	Das Ding
11	96.0002 MHz	0.0000006 μV	

Isotropic Result

Fmin:	75 MHz	Fcent:	91.5 MHz	Sweep Time:	328 ms
Fmax:	108 MHz	Fspan:	33 MHz	No. of Runs:	292
RBW:	20 kHz	Result:	AVG	AVG:	16

SPECTRUM ANALYSIS

Which field sources are the major field emitters? The SRM displays a table listing the 20 highest field strength values and matches them to the services present.

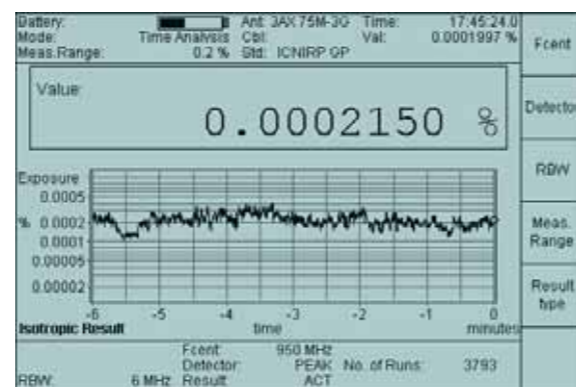

TIME ANALYSIS

How does the channel field strength change over the course of a second? A minute? Hours? The SRM displays the changes, saves the peak values, and averages according to a specific standard or your own settings.



Advanced Test Equipment Rentals
www.atecorp.com 800-404-ATEC (2832)

With its 5 MHz bandwidth, the SRM can already directly and selectively measure an entire UMTS frequency channel. With the UMTS option, it can decode the Primary Common Pilot Channel (P-CPICH). Based on this result, you can extrapolate to the worst case scenario with all traffic channels fully loaded.

Ind	Srv	Value	Max Value	Cell Name
1	182	3.250 $\mu\text{V}/\text{m}$	3.253 $\mu\text{V}/\text{m}$	
2	193	4.839 $\mu\text{V}/\text{m}$	4.839 $\mu\text{V}/\text{m}$	
3	213	3.585 $\mu\text{V}/\text{m}$	3.585 $\mu\text{V}/\text{m}$	Tower North 2
4	310	5.656 $\mu\text{V}/\text{m}$	5.710 $\mu\text{V}/\text{m}$	

Total 8.878 $\mu\text{V}/\text{m}$ 8.876 $\mu\text{V}/\text{m}$

Isotropic Result

Fmin:	2.167 GHz	Process Time:	2.023 s
Fmax:	UMTS DL FDD	No. of Runs:	17
RBW:	Result:	AVG	AVG: 4

UMTS P-CPICH DEMODULATION

How much radiation is due to each UMTS cell? The SRM with UMTS option automatically detects the P-CPICHs, displays the scrambling code used and the corresponding field strength.

EVALUATION. IN LINE WITH CURRENT REGULATIONS

The SRM has all the accepted limit values already stored: ICNIRP (International Commission on Non-Ionizing Radiation Protection), IEEE (Institute of Electrical and Electronic Engineering), FCC (US Federal Communications Commission), Canadian Safety Code 6, and the German BGV B11 (Berufsgenossenschaftliche Vorschrift für Sicherheit und Gesundheit bei der Arbeit) and 26. BImSchV (Bundesimmissionsschutz-Verordnung). You can also define and edit your own limit value curves using the SRM-Tools or SRM-TS PC software.

LOADS

Importing settings, exporting results: easy to do using the RS-232 or USB ports. Using the matching PC software SRM-Tools, for example, you can create or edit tables of services and frequencies, upload the data for your own measuring antennas and cables, load new limit value curves, or upgrade the software and transfer everything to the SRM. Or you can download the results from the SRM and paste them into standard applications or your own, special, documentation. If you have a lot of results to save and manage, you can step up to the SRM-TS PC software instead (page 20).

STANDARD-COMPLIANT WEIGHTING.

The measured values of field strength are physical quantities, so they are "neutral" results. The resulting radiation exposure is the relationship between the measured field strength and a frequency-dependent limit value, which makes it a "weighted" result. These limit values are set at different levels by different bodies: the ICNIRP (International Commission on Non-Ionizing Radiation Protection), the IEEE (Institute of Electrical and Electronic Engineering) and others. The occupational standard in Germany is known as BGV B11 (Trades Union Regulation for Health and Safety at Work). For the private and public sector, the applicable standard is the 26th BImSchV (Federal Immission Protection Regulation), which is based on ICNIRP. You can simply choose the weighting you want from the SRM Configuration menu.

THE SRM FROM NARDA. STANDARD-COMPLIANT MEASUREMENTS. IN THE PALM OF YOUR HAND, ANYWHERE.

SAFETY EVALUATION: AUTOMATED FOR SAFETY.



No need for long tables of frequencies, or complex weighting factors. From the Configuration menu, simply select the services you want to measure, and the standards you want to use for evaluation. Narda has prepared tables of services and corresponding frequency ranges for the major countries. These tables can be edited or new ones created using the PC software. Just enter a name for the service, along with the upper and lower frequency limits. You can do the same for the frequency ranges of individual providers: simply enter the provider's name and the frequency limits. When you're ready, upload the data to the SRM using the serial or USB port. These tables are then ready for use, at any time.

ONE BUTTON TO PRESS FOR A COMPLETE MEASUREMENT.

The usual way of expressing the result is as a percentage of the permitted limit level. The SRM does this by automatically evaluating each spectral line according to the selected standard or regulation. If you prefer absolute values, you can simply switch the display to field strength (V/m) or power density (W/m²). The results are no longer weighted.



Service	Value	Frequency	Sel. serv. service
CEM-R UL	0.0000009	876.000 MHz to 880.000 MHz	last
Vodafone UL900	0.0000004	890.200 MHz to 892.400 MHz	service
T-Mobile UL900	0.0000014	892.600 MHz to 899.800 MHz	service
Vodafone UL900	0.0000012	900.000 MHz to 906.000 MHz	all
T-Mobile UL900	0.0000008	906.200 MHz to 914.400 MHz	service
Vodafone UL900	0.0000007	910.600 MHz to 914.800 MHz	service
T-Mobile UL900	0.0000001	914.400 MHz to 914.800 MHz	service
E-Plus DL	0.0000032	925.200 MHz to 920.000 MHz	Meas. Range
O2 DL900	0.0000009	930.200 MHz to 935.000 MHz	Meas. Range
Vodafone DL900	0.0000009	935.200 MHz to 937.400 MHz	Meas. Range
T-Mobile DL900	0.0000274	937.600 MHz to 944.800 MHz	Meas. Range
Total	0.0012693	876.000 MHz to 959.800 MHz	Result type
Isotropic Result			
Fmin:	876 MHz	Process Time:	576 ms
Fmax:	959.8 MHz	No. of Runs:	18
REW:	100 MHz(Auto)	Result:	AVG AVG: 8

In Safety Evaluation mode, the SRM automatically displays the overall field exposure level (Total) as a percentage of the permitted limit value, as well as the contribution of each separate service to the total.



Safety Evaluation with a single axis measuring antenna?

No problem with the SRM. First axis, first measurement, and the SRM shows the first intermediate result. Turn the antenna, make the second measurement, and the SRM shows the updated result. Same again for axis number three; the third measurement gives the final result.



Advanced Test Equipment Rentals
www.atecorp.com 800-404-ATEC (2832)

UMTS frequency bands have generally cost operators a lot of money to secure. They are well defined and can be measured by frequency selection. The field exposure due to a single UMTS frequency channel is thus easy to determine, and can be matched up with its known operator.

You can't use frequency selection for everything else, since the latest pulse code modulation procedures mean that everything takes place within this frequency band. Every UMTS cell, and every voice or data channel uses the same, roughly 5 MHz wide frequency band. They can only be distinguished by the code used. Each cell uses its own so-called scrambling code.

So the SRM doesn't just directly measure the field strength of the entire UMTS channel using a resolution bandwidth of 5 MHz. Fitted with the UMTS option, it also decodes all the scrambling codes that appear in the selected UMTS frequency channel.

In this way, it can determine the proportion each cell contributes to the whole and list each one separately. It also calculates the sum of these proportions. The worst case situation, where every voice or data channel is fully loaded, can be extrapolated from this.

Ind	Scr	Value	Max Value	Value/Analog	Select Menu
1	73	0.000 mV/m	1.688 mV/m	-99.00 dB	Select
2	182	2.971 mV/m	4.630 mV/m	-16.72 dB	All
3	193	5.764 mV/m	19.50 mV/m	-10.97 dB	Extr. Pol OFF
4	212	4.833 mV/m	9.763 mV/m	-12.50 dB	
5	310	3.902 mV/m	6.024 mV/m	-14.16 dB	Extr. Pol Factor
Total		9.615 mV/m	21.89 mV/m		
Analog		18.23 mV/m	30.44 mV/m		
Isotropic Result			Extr. Fact. 1.25		
Fcent:		2.1672 GHz	Process Time:	1.621 s	Get Table
SENSITIVE Full Table		Result:	UMTS DL No. of Runs:	130	

The SRM uses the variable extrapolation factor to calculate the worst case values for the results of UMTS P-CPICH demodulation: "Value", "Max. Value", "Total". The actual value resulting from an analog measurement is shown as "Analog".

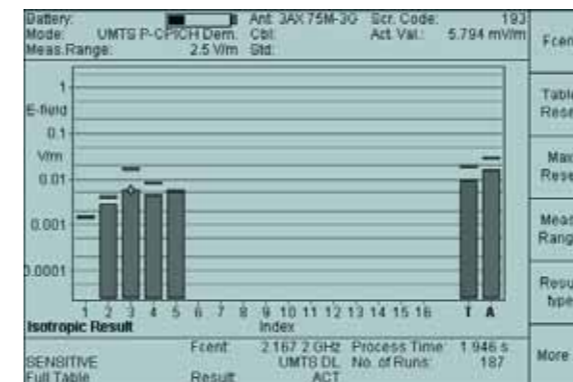

Clear bar graph display of instantaneous values with indication of maximum value. The scrambling codes shown can be selected, e.g. according to service operator.

SELECTION, DEMODULATION, EVALUATION.

The SRM evaluates the results according to the applicable safety standards and shows the results down to each separate radio channel and cell, or collected together according to operator, communications service, or entire radio frequency ranges.

**THE SRM FROM NARDA.
MEASURES SAFETY.
RELIABLY.**



SPATIAL AVERAGING: SPATIAL RESOLUTION AND AVERAGING FUNCTIONS.

Close to transmitter arrays and in reflecting spaces, the field strength is not distributed evenly. There are definite "hot spots" and minima. To realistically determine how humans are affected, various standards require spatial averaging over a volume corresponding roughly to the human body. The "Spatial Averaging" function of the SRM (option) makes this easy. The measuring antenna is simply moved along the desired path in space for continuous averaging. For discrete averaging, pressing a button adds the measured value at each required point in space. The SRM then averages the values automatically and displays the resulting average value according to IEEE as the end result, for example.

Service	Value	Frequency
FH Radio	3.861 $\mu\text{W}/\text{m}^2$	88,000 MHz to 108,000 MHz
Paging	398.5 $\mu\text{W}/\text{m}^2$	152,000 MHz to 159,000 MHz
TV Ch. 7-13	1.599 $\mu\text{W}/\text{m}^2$	174,000 MHz to 216,000 MHz
TV Ch. 14-69	3.998 $\mu\text{W}/\text{m}^2$	470,000 MHz to 806,000 MHz
SRM Tx	145.7 $\mu\text{W}/\text{m}^2$	806,000 MHz to 821,000 MHz
Private Ind mob	29.39 $\mu\text{W}/\text{m}^2$	821,000 MHz to 824,000 MHz
Cellular AMPS	238.2 $\mu\text{W}/\text{m}^2$	824,000 MHz to 849,000 MHz
EDGE/Land mob.	189.4 $\mu\text{W}/\text{m}^2$	849,000 MHz to 869,000 MHz
Cellular AMPS	224.1 $\mu\text{W}/\text{m}^2$	869,000 MHz to 894,000 MHz
Aeronautical mobil	17.88 $\mu\text{W}/\text{m}^2$	894,000 MHz to 896,000 MHz
Private Ind mob	43.04 $\mu\text{W}/\text{m}^2$	896,000 MHz to 901,000 MHz
Total	46.16 $\mu\text{W}/\text{m}^2$	88,000 MHz to 1990,000 MHz
Isotropic Result		
Fmin:	88 MHz	Process Time 1.526 s
Fmax:	1.95 GHz	No. of Runs: 4
RBW:	200 kHz(Auto)	Result SAVG No. of SAVG: 21

SPATIAL AVERAGING

How high is the average field exposure determined over the volume of the human body? The SRM averages several spatial values continuously or discretely and displays the result directly at the end of the procedure.

If you need to determine the field strength due to individual wireless services, service providers, or even a single channel, the frequency resolution must be fine enough for the job. The SRM lets you analyze each channel separately in the mobile phone or DECT band without any trouble. If you want to know the total power level in the frequency band, you don't have to make a new measurement. The integration function will give you the value.

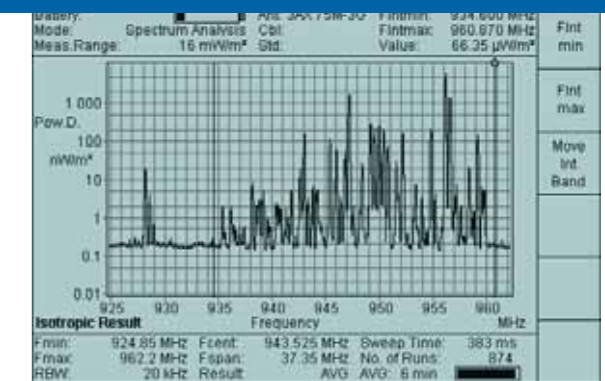

SPECTRUM ANALYSIS

How high is the total power level? The integration range can be set just as easily as the zoom range. The numerical result is displayed automatically at the top right of the measurement window.

TIME ANALYSIS: TIME RESOLUTION AND TIME AVERAGING.

Pages switch on and off without warning, communications channels are used sporadically, so the frequency spectrum is constantly changing. In "Time Analysis" mode, the SRM can record the variation with time down to one-second accuracy, so you can see how individual channels behave over a period of time. With "Time Controlled Storing" (option), you can pre-program a specific starting time and measurement duration. Most standards prescribe time averaging over a six-minute period to determine exposure levels for the human body. The SRM does this automatically, too, regardless of the observation period displayed on the screen.

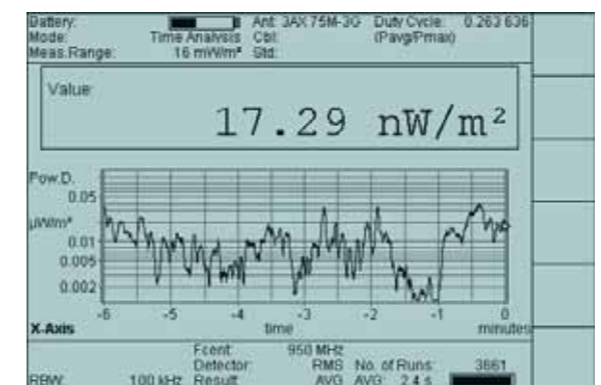

TIME ANALYSIS

Past values can be read out using the marker. The so-called duty cycle function automatically determines the ratio of average to maximum power (Pavg/Pmax).

MAXIMUM VALUES AND AVERAGES.

Where is the field strength highest in the room? At what frequency? When do peak values occur, and how long do they last? The SRM shows all this directly. And if you need to know the average values instead, the SRM shows them, too.

**THE SRM FROM NARDA:
 ANALYZES, AVERAGES, AND INTEGRATES.
 IN FREQUENCY, SPACE, AND TIME.**

ONE AXIS OR THREE? THE RIGHT MEASURING ANTENNA FOR T

The isotropic measuring antennas for the SRM measure in three mutually perpendicular axes. Even with the close connection to the SRM basic unit, their anisotropy, i.e. the degree to which they deviate from the ideal isotropic characteristic, is so good that most measurements can be made with the instrument held in your hand. The antenna can be mounted on a tripod and connected to the SRM by a cable when utmost precision is required. This minimizes the effects of reflections from the instrument casing and the person making the measurement.

Single axis measurement antennas from Narda are ideal for high sensitivity measurements at up to 3 GHz or for precision measurements of electric and magnetic fields down to 100 kHz. They can also be used to make three axis measurements with the SRM. All you need is a mounting that allows the receiving axis of the antenna to be oriented in three mutually perpendicular positions. The SRM saves the result for each of the three axes, and then calculates the resulting field strength. You can also use the isotropic antennas for single axis measurements. Simply switch to "uniaxial" in the SRM menu and select the desired receiving axis.



Advanced Test Equipment Rentals
www.atecorp.com 800-404-ATEC (2832)

Antenna type	Three axis E-field antenna (isotropic), passive dipole array	Single axis E-field antenna, passive dipole	Single axis E-field antenna, active dipole	Three axis H-field antenna (isotropic), active coil array	Single axis H-field antenna, active coil
Frequency range	75 MHz to 3 GHz	27 MHz to 3 GHz	100 kHz to 300 MHz	100 kHz to 250 MHz	100 kHz to 300 MHz
Recommended application	Fast, non-directional measurements, e.g. at mobile phone frequencies	Precision measurements at VHF and TV frequencies	Precision measurements of electric fields on radio / TV transmitters and industrial plant	Fast, non-directional near-field magnetic field measurements on radio / TV transmitters and industrial plant	Precision near-field magnetic field measurements on radio / TV transmitters and industrial plant

Measuring antennas from other manufacturers can also be used with the SRM basic unit.

There are three dipoles arranged on mutually perpendicular axes inside the isotropic E-field antenna.

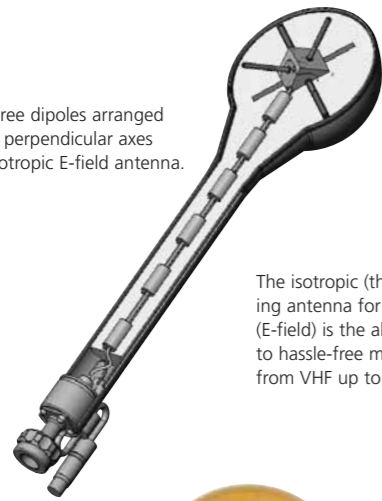

The isotropic (three axis) measuring antenna for electric fields (E-field) is the all-round answer to hassle-free measurements from VHF up to UMTS.

High-sensitivity single axis E-field antennas can be fitted to a tripod and positioned for precision measurements. Held in the hand, they are also suitable for locating maximum values within a room.

The single axis H-field antenna lets you make precise measurements of magnetic field components close to transmitters and industrial plant.

The measurement antenna connection to the SRM basic unit is an N connector. The basic unit can read the measuring antenna data from an EPROM via an auxiliary control cable.



AUTOMATICALLY CORRECT.

Strictly speaking, the SRM doesn't measure the electromagnetic field. It measures the voltage that the field induces at the output of the measuring antenna. The so-called antenna factor must be known before the results can be shown as field strengths. Precision measurements demand that this factor is determined for each antenna separately at various frequencies and then applied during evaluation. No problem with Narda measuring antennas. The antenna factors are stored in the antenna itself during calibration. The SRM recognizes them and applies them automatically.

**THE SRM FROM NARDA.
 RECOGNIZES ITS OWN MEASURING ANTENNAS.**

SRM-TS PC SOFTWARE. DATABASE FOR HANDLING DEVICE DATA AND ANY NUMBER OF RESULTS.

It's easy to get results with the SRM. And just as easy to get a lot of results. To handle all this data easily, too, you can use the SRM-TS PC software.

SRM-TS can download all the results from the SRM and save them in databases on a PC. The results can then be analyzed further, e.g. for peak or average values in the time domain or in the frequency domain. The zoom function lets you take a closer look at certain details. You can also paste the results into the usual Office applications, so you can easily prepare customer-specific test reports.

Going the other way, you can configure the test set from the PC using SRM-TS. Import and export functions let you upload antenna data from other manufacturers into the test set, for example.

In on-line mode, you can use SRM-TS to make all the settings on the test set and carry out timer controlled measurements from your PC. The results are displayed directly on the monitor. That is an advantage when you're monitoring the radiation levels over a long period. The measuring antenna is placed in the desired position relative to the radiation source; the test set is located close by, but is remote-controlled from your office up to 100 m away using an electro / optical serial interface (RS232).

This remote operation via optical cable is also very useful if you want to avoid any influence on the field that might be caused by the person making the measurement.



Advanced Test Equipment Rentals
www.atecorp.com 800-404-ATEC (2832)



OPTIONAL ACCESSORIES

Additional cables

- High frequency cables
- USB adapter cables
- Serial interface cables and optical / electrical converters

Power supply

- Additional batteries

Antenna holders

- Antenna holder for single axis and three axis antennas
- Antenna holder for three axis antennas allowing horizontal and vertical fitting
- Tripod adapter
- Tripod

Other antennas

- Single axis E-field measuring antennas
- Single and three axis H-field measuring antennas (see p. 19)

Software

- SRM-TS with convenient evaluation and management functions



BASIC EQUIPMENT.

SRM-3000 is the designation for a complete set of basic equipment. It includes the SRM basic unit, the isotropic E-field measuring antenna, a carry strap, various cables, batteries, and an AC adapter / charger unit, as well as the SRM-Tools PC software. All packed in a rugged hard shell case. Or, if you prefer, in a soft case on rollers.

READY TO GO!



LOW-FREQUENCY TEST EQUIPMENT

Test equipment for electric and magnetic fields from DC up to several hundred kilohertz. For power utility companies, electric railroads, industry. Standard-compliant evaluation, e.g. conforming to the EN 50366 standard for domestic appliances.



BROADBAND HIGH-FREQUENCY TEST EQUIPMENT

NBM-500 – the new series that covers practically every application between 100 kHz and 60 GHz.



SELECTIVE HIGH-FREQUENCY TEST EQUIPMENT

SRM-3000 – the tester that selectively detects and measures every source in the range from 100 kHz to 3 GHz. With a sensitivity that can still detect individual telecommunications channels, even inside buildings.



PERSONAL MONITORS

Worn on the body, these devices give reliable warning of excessive radiation levels.



AREA MONITORING STATIONS

For permanent monitoring of the field strength situation. Frequency-selective or broadband. With data transfer via mobile phone.

EVERYTHING YOU NEED FOR SAFETY IN ELECTROMAGNETIC FIELDS

Narda Safety Test Solutions is a global leader in the development and production of measuring equipment for electric, magnetic, and electromagnetic fields. The fact that we own around 95% of all published patents for measuring such fields bears witness to this. Choosing a Narda instrument is choosing a product from a company renowned for innovation, that is specialized in EMF (measurements for safety in electromagnetic fields), and that is continually building upon its reputation in this sector.

THREE LOCATIONS – ONE GOAL

Our three sites are located at Hauppauge, Long Island (USA), Pfullingen (Germany), and Cisano (Italy). Our goal is to provide you, the user, with products tailored exactly to your needs, using the highest quality in cutting-edge technology.

WHAT WE OFFER

Our comprehensive range of products for human safety in electromagnetic fields (EMF) includes broadband measuring instruments, selective measurement equipment, monitoring stations, and personal radiation monitors. Under our PMM brand, we offer instruments for assessing the electromagnetic compatibility (EMC) of devices. As our customer, you can benefit from our program of services, including servicing, calibrating, and training.

B1.6 WaveControl SMP2 / WP400 Datasheet

SMP2



Electromagnetic field meter



3 INSTRUMENTS IN 1:
Static field measurement, Spectrum analysis & Broadband field meter



FFT-BASED TIME-DOMAIN SPECTRUM ANALYSIS
From 1 Hz to 400 kHz



EMF WORKER'S SAFETY
ICNIRP, EU Directive, FCC, SC6 (2015),...



BROADBAND MEASUREMENT
(0 Hz - 60 GHz)



Ready for 5G measurements



Field probe range
from 0 Hz to 60 GHz

Spectrum analysis [FFT]
(up to 400 kHz)

Broadband measurements
(0 Hz - 60 GHz)

Field values:
X, Y, Z and Total

Graphical display
in real time

Dynamic menu

Weighted Peak Method (WPM)
Real time comparison with limits

> 1 million registers
SQL data base

Screenshot function

Fibre optics (optional)

USB

Available field probes

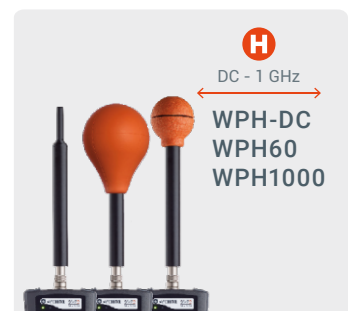
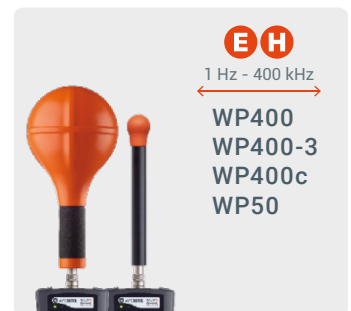

SMP2 Applications



Industry



Telecommunications



Energy



Railway



Medical



Labs



Aeronautical



Worker's safety



Defense



Technical specifications

Versions	Broadband	For broadband measurements using the following probes: WPFx, WPT, WP50, WPH60 and WPH1000.
	Selective	For frequency selective measurements from 0 to 400 kHz using WP400, WP400-3, WP400c and WPH-DC.
	Dual	For both kinds of measurements using all field probes.
Field probes	Automatic detection and recognition	
Broadband	0 Hz – 60 GHz (depending on field probe)	
Spectrum analysis	up to 400 kHz	
Weighted Peak Method	1 Hz – 400 kHz (Real time WPM for direct comparison with limits)	
Readout values	Total field (instantaneous, max., min. and average) Field components (X, Y, Z)	
E Field units	V/m, kV/m, $\mu\text{W}/\text{cm}^2$, mW/cm^2 , W/m^2 , %	
H Field units	nT, μT , mT, T, A/m, %, mG, G	
Log time	Configurable (from 0.5 s to 6 min)	
Average modes	Fixed or Sliding, according to international standards	
Average intervals	10 s, 15 s, 30 s, 1 min, 2 min, 5 min, 6 min, 10 min, 15 min, 30 min	
Schedule measurement	Customized (up to 24 hours)	
Memory capacity	More than 1 million samples	
Data downloading	Mini-USB and Fibre Optics	
Firmware updating	Mini-USB	
Alarm	2400 Hz audible signal (adjustable threshold)	
Display type	Color transmissive TFT (480 x 272 pixels)	
GPS (optional)	Built-in u-blox 7 (56 independent tracking channels)	
Battery	Internal rechargeable Li-ion	
Autonomy	> 24 hours	
Temperature range	-10 °C to +50 °C	
Humidity	5% to 95%, non-condensing	
Size	100 x 215 x 40 mm (3.9 x 8.4 x 1.5 ")	
Weight	Broadband	560 g (19.7 oz.)
	Selective	635 g (22.4 oz.)
	Dual	635 g (22.4 oz.)

Product specifications and descriptions in this document subject to change without notice

SMP2

Electromagnetic field meter. Compatible field probes

Wavecontrol provides a full range of E-Field, H-Field and E&H Field probes covering different frequency ranges starting at 0 Hz and up to 60 GHz.

Probes are plug and play and come with an individual ISO 17025 accredited calibration. All sensors are isotropic, RMS and highly accurate.

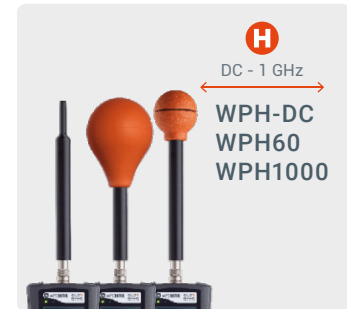
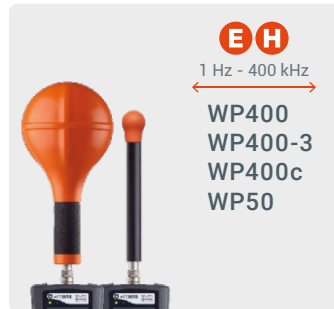
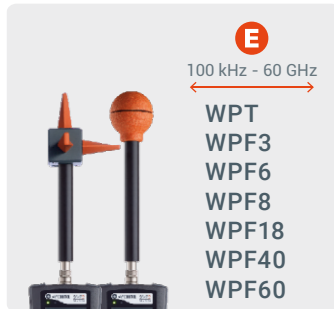

Frequency range of compatible field probes

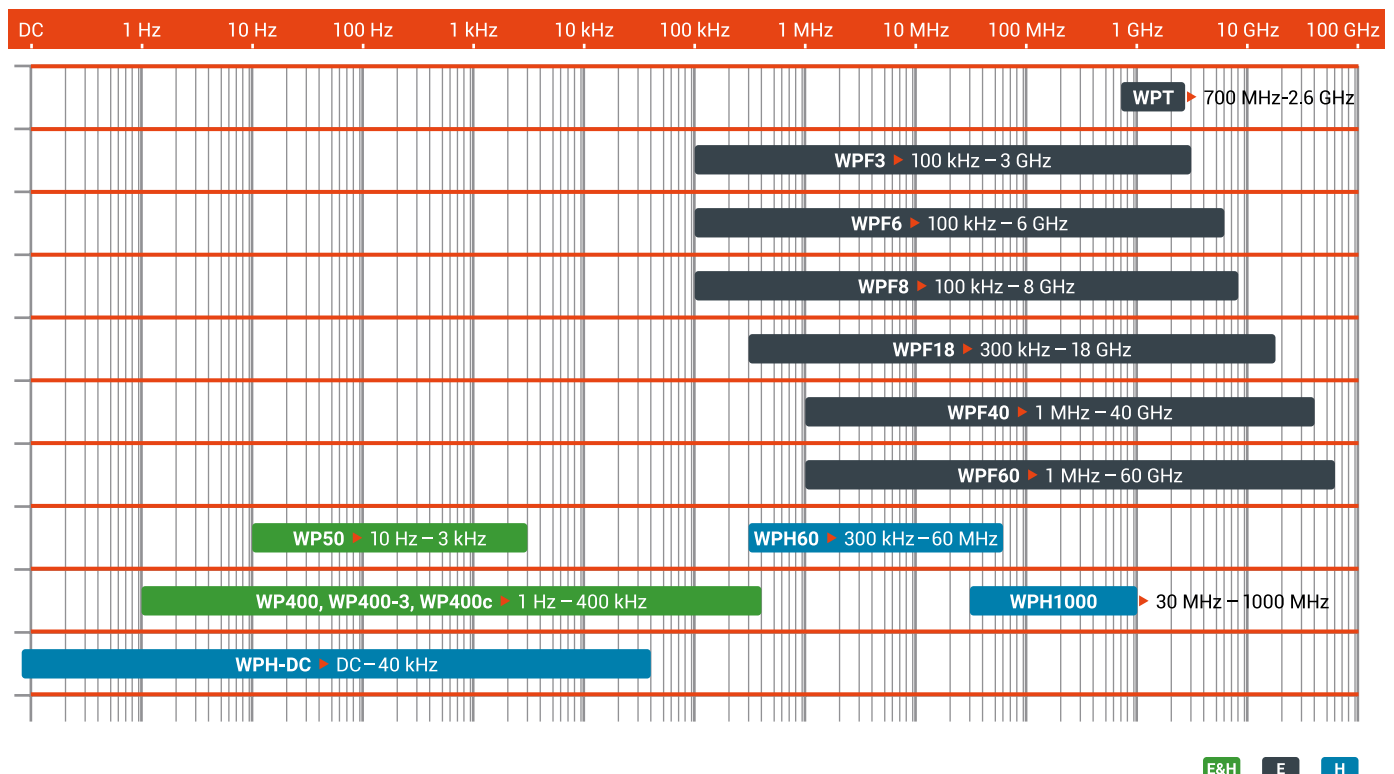

Model	Frequency range	Response	Measurement range	Linearity	Size
WPH-DC Selective & Broadband	0 – 40 kHz	Flat	H-Field: 10 μ T – 10 T	0.6% (100 μ T – 1 T) 1% (100 μ T – 2.4 T)	27.3 cm x 2.1 cm \emptyset 10.8 " x 0.8 " \emptyset Sensor stick: 0.94 cm \emptyset 0,37 " \emptyset
WP400 Selective & Broadband	1 Hz – 400 kHz	Flat / Shaped (Weighted Peak Method)	E-Field: 1 V/m – 100 kV/m H-Field: 50 nT – 30 mT @50 Hz 50 nT – 10 mT (100 Hz – 10 kHz)*	\pm 1% (Typical) \pm 2% (Maximum)	28 cm x 12.8 cm \emptyset 11 " x 5 " \emptyset
WP400-3 Selective & Broadband	1 Hz – 400 kHz	Flat / Shaped (Weighted Peak Method)	E-Field: 10 V/m – 400 kV/m H-Field: 200 nT – 50 mT (100 Hz – 10 kHz)*	\pm 1% (Typical) \pm 2% (Maximum)	27.5 x 3.3 cm \emptyset 10.8 " x 1.3 " \emptyset
WP400c Selective & Broadband	1 Hz – 400 kHz	Flat / Shaped (Weighted Peak Method)	E-Field: 1 V/m – 100 kV/m H-Field: 50 nT – 30 mT @50 Hz 50 nT – 1.5 mT (820 Hz – 40 kHz)*	\pm 1% (Typical) \pm 2% (Maximum)	28 cm x 12.8 cm \emptyset 11 " x 5 " \emptyset
WP50	10 Hz – 3 kHz	Flat / Shaped	E-Field: 2.5 V/m – 20,000 V/m H-Field: 0.05 μ T – 2,000 μ T	\pm 1% (Typical) \pm 2% (Maximum)	27 cm x 11.5 cm \emptyset 10.6 " x 4.5 " \emptyset
WPH60	300 kHz – 60 MHz	Flat	H-Field: 0.018 – 1 A/m (RMS) 0.018 – 20 A/m (CW)	\pm 1 dB (0.04 – 4 A/m)	27 cm x 9 cm \emptyset 10.6 " x 3.5 " \emptyset
WPH1000	30 MHz – 1000 MHz	Flat	H-Field: 0.018 – 20 A/m	\pm 1 dB (0.04 – 4 A/m)	28.4 cm x 6 cm \emptyset 11.2 " x 2.4 " \emptyset
WPF3	100 kHz – 3 GHz	Flat	E-Field: 0.2 – 20 V/m (RMS) 0.2 – 130 V/m (CW)	\pm 0.5 dB (0.5 – 100 V/m)	28.4 cm x 6 cm \emptyset 11.2 " x 2.4 " \emptyset
WPF3-HP		Flat	E-Field: 0.2 – 20 V/m (RMS) 0.2 – 1,000 V/m (CW)	\pm 0.5 dB (0.5 – 100 V/m)	28.4 cm x 6 cm \emptyset 11.2 " x 2.4 " \emptyset
WPF6	100 kHz – 6 GHz	Flat	E-Field: 0.2 – 20 V/m (RMS) 0.2 – 130 V/m (CW)	\pm 0.5 dB (0.5 – 100 V/m)	28.4 cm x 6 cm \emptyset 11.2 " x 2.4 " \emptyset
WPF6-HP		Flat	E-Field: 0.2 – 20 V/m (RMS) 0.2 – 1,000 V/m (CW)	\pm 0.5 dB (0.5 – 100 V/m)	28.4 cm x 6 cm \emptyset 11.2 " x 2.4 " \emptyset
WPF8	100 kHz – 8 GHz	Flat	E-Field: 0.2 – 20 V/m (RMS) 0.2 – 130 V/m (CW)	\pm 0.5 dB (0.5 – 100 V/m)	28.4 cm x 6 cm \emptyset 11.2 " x 2.4 " \emptyset
WPF8-HP		Flat	E-Field: 0.2 – 20 V/m (RMS) 0.2 – 1,000 V/m (CW)	\pm 0.5 dB (0.5 – 100 V/m)	28.4 cm x 6 cm \emptyset 11.2 " x 2.4 " \emptyset
WPF18	300 kHz – 18 GHz	Flat	E-Field: 0.5 – 30 V/m (RMS) 0.5 – 250 V/m (CW)	\pm 0.5 dB (0.5 – 100 V/m)	28.4 cm x 6 cm \emptyset 11.2 " x 2.4 " \emptyset
WPF18-HP		Flat	E-Field: 0.5 – 30 V/m (RMS) 0.5 – 1,000 V/m (CW)	\pm 0.5 dB (0.5 – 100 V/m)	28.4 cm x 6 cm \emptyset 11.2 " x 2.4 " \emptyset
WPF40	1MHz – 40 GHz	Flat	E-Field: 1 – 55 V/m (RMS) 1 – 1,000 V/m (CW)	\pm 2 dB (1 – 2 V/m) \pm 1 dB (2 – 250 V/m)	28.4 cm x 6 cm \emptyset 11.2 " x 2.4 " \emptyset
WPF60	1MHz – 60 GHz	Flat	E-Field: 1 – 55 V/m (RMS) 1 – 1,000 V/m (CW)	\pm 2 dB (1 – 2 V/m) \pm 1 dB (2 – 250 V/m)	28.4 cm x 6 cm \emptyset 11.2 " x 2.4 " \emptyset
WPF60S	1MHz – 60 GHz	Shaped (ICNIRP 1998/2020, FCC)	E-Field: 0.1% – 35% (RMS) 0.1 – 800% (CW)	\pm 2 dB (1 – 2 V/m) \pm 1 dB (2 – 250 V/m)	28.4 cm x 6 cm \emptyset 11.2 " x 2.4 " \emptyset
WPT	Selective: 700 – 900, 1800 – 1900, 2100, 2600 Hz	Flat	E-Field: 0.04 – 65 V/m (RMS)	\leq 0.4 dB (0.2 – 50 V/m)	28.5 x 10.5 x 10.5 cm 11.2 x 4.1 x 4.1 "
WP-WIFI	WiFi 2.45 GHz	Flat	E-Field: 0.04 – 65 V/m (RMS)	\leq 0.5 dB (0.2 – 50 V/m)	28.5 x 10.5 x 10.5 cm 11.2 x 4.1 x 4.1 "

*Below and above the stated frequency range, upper limit of the measurement range changes (See datasheets for more information).

Visit www.wavecontrol.com/rfsafety/en/products/probes, for detailed datasheets of each field probe model.

SMP2

Electromagnetic field meter. Accessories

SMP2 included accessories

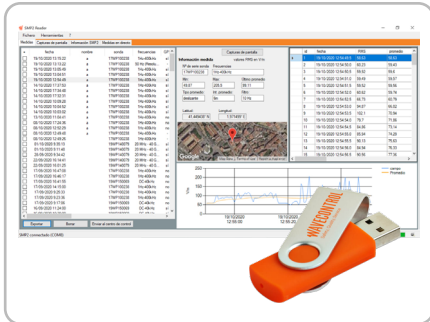

'SMP2 Reader' PC software
Included / Downloadable from wavecontrol.com

Compatible with Windows 7 or later versions



SMP2 carrying case
Part # WSN0001-2-3

Robust case to fit the SMP2 and up to 5 probes



USB cable

USB to mini-USB
cable



AC/DC charger

International plug
types available

SMP2 optional accessories



Non-reflective wooden tripod
Part # WSNA0001

Including transport cover



Tripod extension
Part # WSNA0002

Horizontal extension for LF vertical E-field
measurements



**Probe support for
tripod**

Part # WSNA0013

Recommended with
the probe extension
cable



**Probe extension
cable**

Part # WSNA0011

5-meter extension
cable

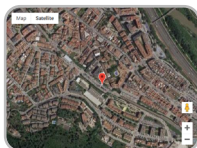

GPS
Part # WSN00001

Internal embedded
GPS



**Fiber optics
interface**
Part # WSNA0004

10-meter fiber optics
+ Converter USB
to PC



**Vehicle DC
charger**
Part # WSNA0007

Charge SMP2 from a
vehicle DC connector



**SMP2 protective
pouch**
Part # WSNA0009

Easily portable
protective soft
sheath



SMP2 backpack
Part # WSNA0008

Soft backpack to fit up to 3 probes

WP400 Probe

1 Hz - 400 kHz



- Electric & Magnetic field measurement
- Isotropic & True RMS measurement
- Spectrum analysis probe
- Measurements in accordance with International Standards
- 100 cm² sensor

1 Hz - 400 kHz

E & H

RMS

ISOTROPIC

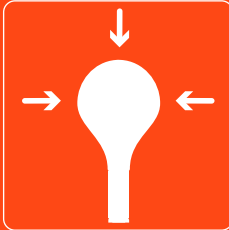

Power grid
Measurement of the exposure to EM fields at transformer stations and high-voltage lines.



Railway
Measurement of EM fields in trains and in the railway environment with respect to human exposure.



Industry
Assessment of workers' exposure to EM fields in all kind of manufacturing facilities.



Technical Specifications

	Electric Field	Magnetic Field
Sensor type	Isotropic patented electrodes	
Frequency range	1 Hz - 400 kHz	1 Hz - 400 kHz
Field Strength Mode		
Measurement range	1 V/m to 100 kV/m	50 nT - 30 mT @ 50 Hz 50 nT - 10 mT (100 Hz - 10 kHz) · Upper range increases linearly with decreasing frequency below 100 Hz. · Upper range decreases linearly with increasing frequency above 10 kHz.
Graphical display	RMS, Axis Values, AVG, MAX, MIN, PEAK, RMS time graph	
Peak value	digital realtime	digital realtime
Resolution	< 0.4 mV/m above 8 Hz	< 0.1 nT (at 50 Hz) and < 0.05 nT above 100 Hz
Noise level	< 1 V/m (10 Hz - 400 kHz)	< 50 nT (10 Hz - 400 kHz)
Weighted Peak Method mode		
Measurement range	200 % (min)	200 % (min)
Graphical display	PEAK (%), AXIS VALUES (%), AVG (%), MAX (%), MIN (%), RMS (%), Time graph	
Standards/Limits	EU Directive 2013/35/EU, IEEE, ICNIRP, BGV B11. Easy software update to future modifications and to other limits.	



WP400_EN_2005_v2.3

WP400 Probe

1 Hz - 400 kHz



Technical Specifications

	Electric Field	Magnetic Field
FFT Mode		
Measurement range	4 mV/m – 100 kV/m	0.5 nT - 30 mT @ 50 Hz 0.5 nT - 10 mT (100 Hz - 10 kHz) · Upper range increases linearly with decreasing frequency below 100 Hz. · Upper range decreases linearly with increasing frequency above 10 kHz.
Graphical display	Frequency analysis, total field and axis	
SPAN (Resolution)	400 Hz (1 Hz) - 4 kHz (10 Hz) - 40 kHz (100 Hz) - 400 kHz (1 kHz)	
Noise level	< 4 mV/m	< 0.5 nT
FFT	1024 point FFT	
General specifications		
Isotropy	± 5 %	± 4 %
Typical Uncertainty (1)	0.67 dB	0.60 dB
Temperature deviation [typ. At 50/60 Hz] (referred to 25 °C, 50 % relative humidity)	- 0.005 dB/°C (- 15 °C to 40 °C)	- 0.003 dB/°C (- 15 °C to 25 °C) + 0.003 dB/°C (25 °C to 40 °C)
Damage level	> 200 kV/m	> 2000 mT up to 60 Hz Damage level decreases linearly with increasing frequency above 60 Hz
Linearity	± 1 % (typ.) ± 2 % (max.)	
Weight	220 g	
Probe size	280 mm x 128 mm Ø	

(1) Total, counting isotropy, temperature deviation, resolution, frequency response, linearity, repeatability.



Product specifications and descriptions in this document subject to change without notice